

SCH333/350K-T2-EU
SCH250/275K-T2-EU

Version: 3.0 Date: December 2025 Doc. No.: 9.0020.1026C0
SHANGHAI CHINT POWER SYSTEM CO., LTD.
Official Site: www.chintpower.com
Customer Service Line: +86-21-37791222-866300

1. Product Dimensions and Main Components

1.1 Product Dimensions

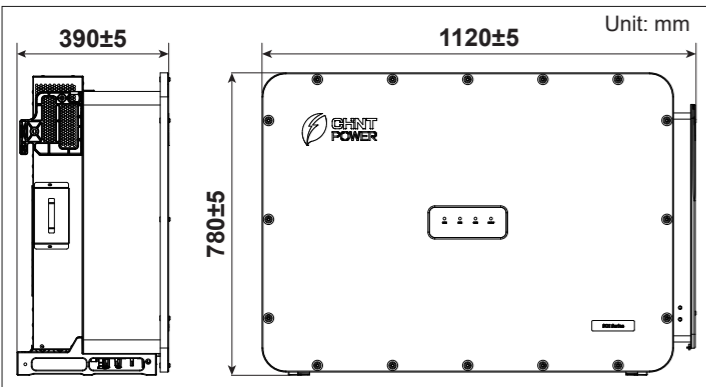

1.2 Main Components

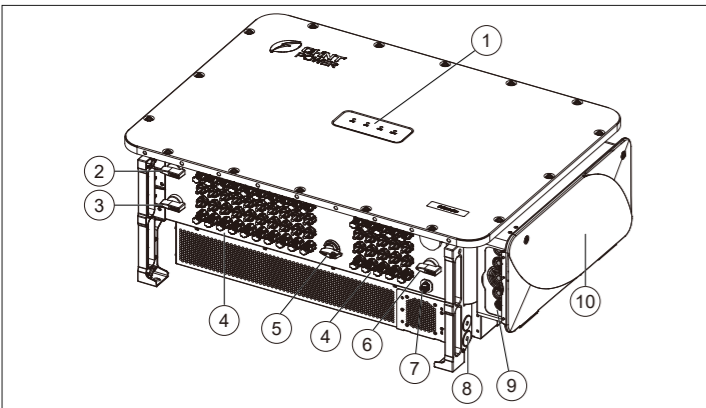

- 1. LED Indicator
- 2. DC Switch (Control PV 1~10)
- 3. DC Switch (Control PV 11~20)
- 4. PV String Connector
- 5. Auxiliary Switch
- 6. DC Switch (Control PV 21~30)
- 7. Communication Interface
- 8. External Grounding Hole
- 9. Rubber Pad for AC Outlet
- 10. AC Wire Box

2. Mechanical Installation

2.1 Scope of Delivery

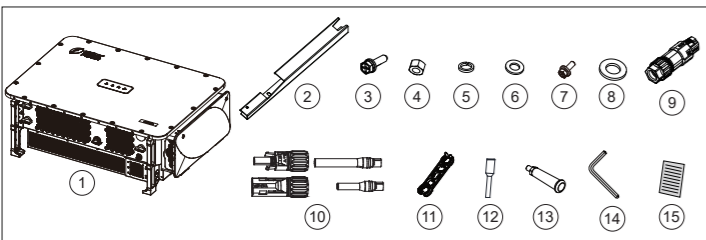

No.	Item	Qty	Description
1	PV Inverter	1	N/A
2	Mounting Bracket	2	For mounting inverter
3	Screw M10x50	4	For mounting bracket
4	Nut M10	4	
5	Spring Washer M10	4	
6	Flat Washer M10	6	
7	Screw M6x18	2	Secure inverter and support structure

No.	Item	Qty	Description
8	Flat Washer M12	3	Secure AC terminal block
9	8-Pin Connector	1	Communication connection
10	DC Input Male(+) Connector	30	PV quick connector
	DC Input Female(-) Connector	30	
11	Unlock tool for DC Connector	1	Unlock connector
12	Plug Rod	1	Plug seal ring of 8-Pin connector
13	Handle	2	Carry the inverter
14	Hex Wrench	1	Open and close wire box side cover
15	Document	1	Quick installation guide

2.2 Recommended Clearances

During planning and installing the inverter, appropriate clearances shown as below shall be reserved to ensure sufficient ventilation and heat dissipation. If the inverters are installed in relatively enclosed space, this clearance shall be increased properly to maintain well ventilated condition. In addition, no objects shall be put in-between two inverters to prevent any negative influences on heat dissipation.

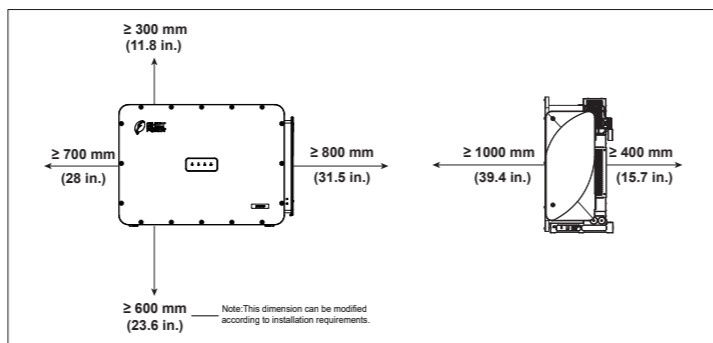

2.3 Installation Mode Requirements

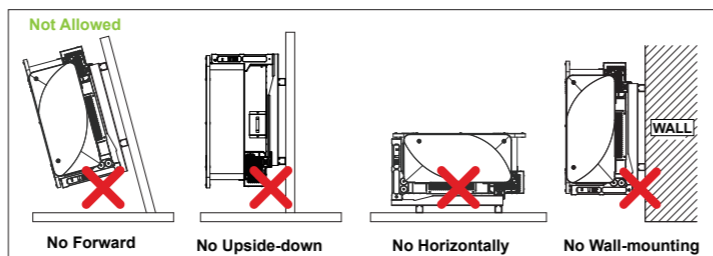
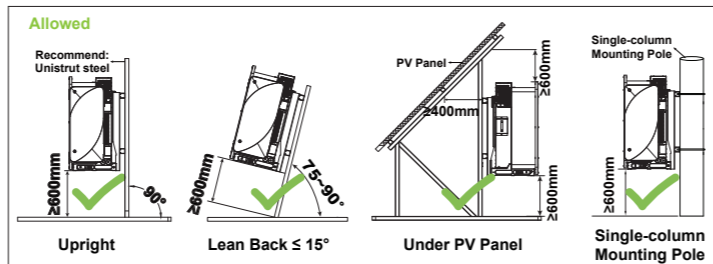

2.4 Installation Environment Requirements

It is recommended to install inverter under a shelter to avoid direct sunlight, rain and snow accumulation, to prevent from triggering power derating, increasing inverter failures or reducing its service life.
Note: Wall installation must be avoided.

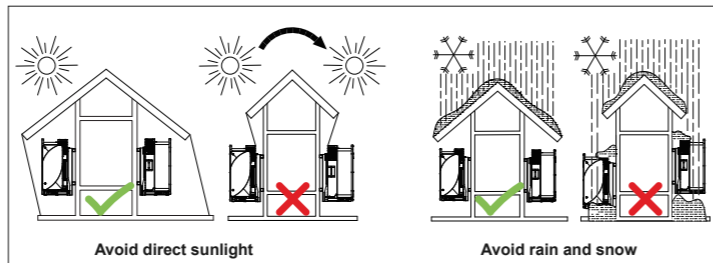

2.5 Install the Inverter onto Bracket

1. Mark the drilling points on the support structure (offered by customer) according to the mounting hole positions and the size of the mounting bracket.

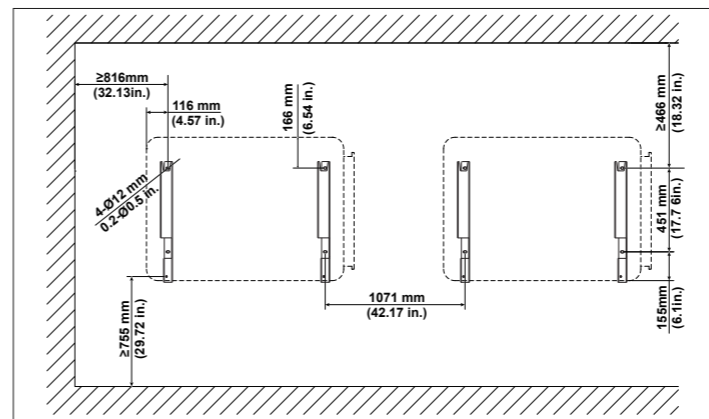

2. Drill holes at the marked positions using a drill. Secure the mounting bracket (5) to the support structure (6) using the M10x50 screws (1), M10 flat washers (2), M10 spring washers (3), and M10 nuts (4).
Tools: Electric drill with Ø12 mm drill bit, 17 mm socket wrench.
Torque: 23 N·m

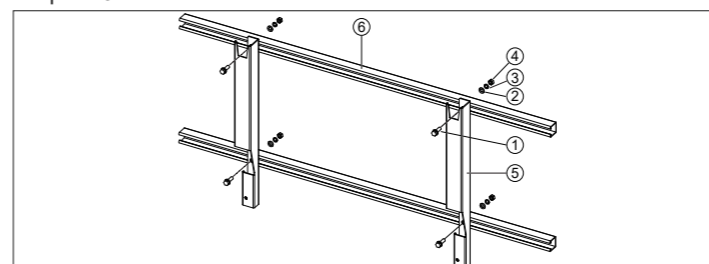

3. Hang the inverter onto the mounting bracket using one of the following methods:

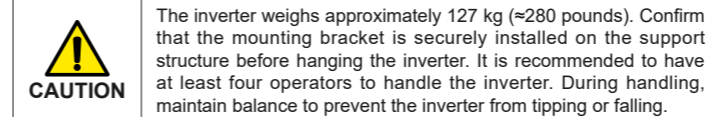

- Manual Lifting: Install two M12 handles in the threaded holes. With four personnel: grip the fixed bottom handles (hollow-centers) and two M12 handles. Lift and hang the inverter onto the mounting bracket.
- Machine Hoisting (Recommended): Screw two M12 lifting eye bolts (offered by customer) into the holes as indicated below. Use lifting slings or a lifting bar to lift the inverter and hang it onto the mounting bracket. Ensuring the angle between the slings is less than 90°.

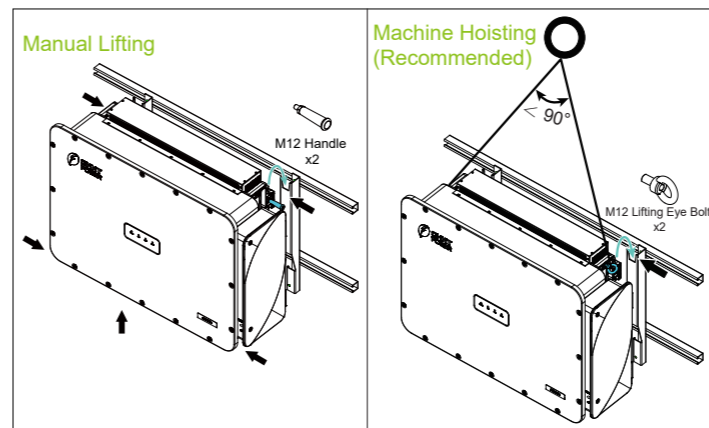

4. Secure the inverter to the mounting structure using the M6x18 screws and M10 flat washers.

Tools: 17 mm socket wrench. Torque: 6 N·m.

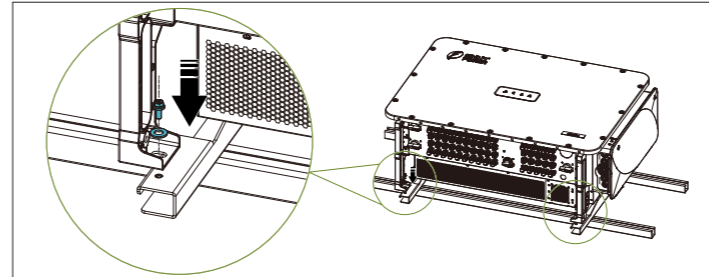

3. Electrical Connection

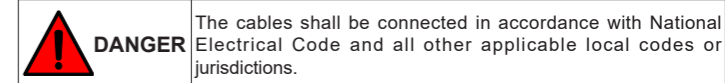

3.1 Tools and Torques

No.	Tool	Usage	Torque
1	No.19 socket wrench	AC output terminal	40 N·m
2	No.17 socket wrench	Internal and external grounding terminals	23 N·m
3	1.5 mm socket wrench	RS485 and CAN communication terminals	0.2 N·m
4	Diagonal pliers, wire stripper, crimping pliers	Cable preparation	N/A

3.2 Cable Specification

Name	Type	Cable Outer Diameter (unit: mm)	Cross-Sectional Area(CSA) (unit: mm ²)
DC Cable	PV cable (1500 V standard)	5.0~7.2 ¹	4~6
AC Cable ²	Outdoor single-core copper / aluminum wire	14~38	• L1, L2, L3:120~400 • PE: ≥ CSA of phase wire conductor / 2
	Outdoor three-core copper / aluminum wire	38~75	
	Outdoor four-core copper / aluminum wire		
Grounding Cable	Outdoor copper-core wire	N/A	Same as AC cable PE
Communication Cable	UTP CAT-5e	4.5~6	3 x 0.2~0.75
	Shielded twisted pair		3 x 1~1.5

Note *1: For selection exceeds the given range, please consult CHINT for feasibility.
Note *2: Do not directly connect aluminum-wire AC cables to the AC terminal block; if using aluminum-wire AC cables, a Cu-Al bimetallic compression lug must be used.

3.3 Grounding (Protection Earthing)

The grounding cable must be connected using at least one of the following methods:

- Internal Grounding: A grounding hole is located inside the AC wire box. One M10x25 screw is pre-installed in this hole and is used to secure the grounding terminal.
- External Grounding: Two grounding holes are located on the machine's exterior near the bottom of the AC wire box. Two M10x25 screws are bundled inside the wire box and are used to secure the grounding terminal.

Note: After wiring, the external PE point needs to be coated with glue or paint. Other sizes of grounding cables that meet local standards and safety regulations can also be used for grounding connections. But CHINT Power shall not be liable for any damage caused.

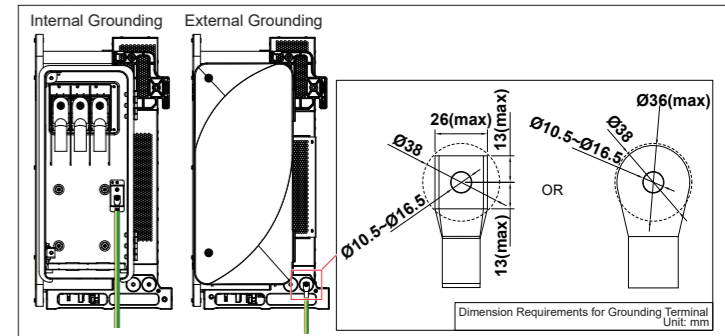

3.4 AC Wiring

1. Loosen the two screws (a) on the wire box to open the side cover. Store the screws safely; if lost, use the two spare screws (b) pre-installed on the wire box.
2. Remove the support rod from the side cover and hook it into the cover's hole to support the cover.

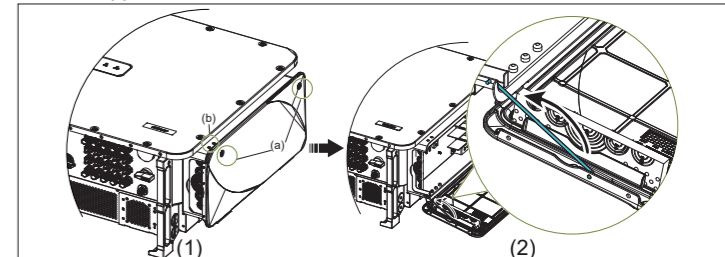

3. Remove the two rubber pads from the wire box cover by hand. Note their initial orientation for wiring and reinstallation.

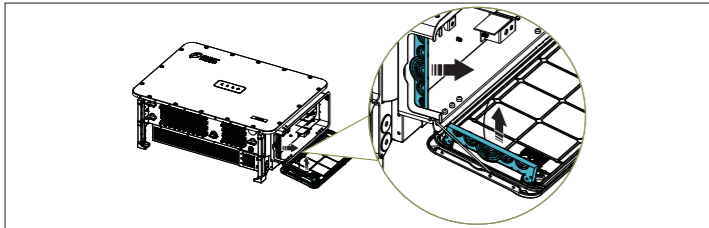

4. Strip an appropriate length of the jacket and insulation layer from the AC cable, insert the exposed core wires into the terminal crimping area, and crimp it with hydraulic pliers. Insulate the crimped area with heat-shrink tubing or insulating tape. (Note: Wrap the wire crimp area with heat shrink tubing or insulation tape.)

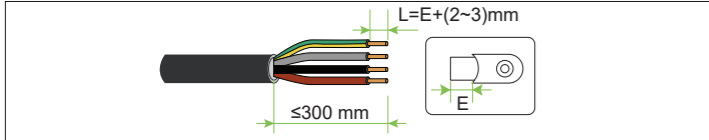

5. Based on the AC cable type, select the matching aperture size and pull the aperture open using hand or pliers. The rubber pad has five cable holes:

- Single-core cable (See Figure A): Use any three of holes ①, ②, ③, or ④ for L1/L2/L3 cable. Use hole ⑤ for grounding cable.
- Multi-core cable (See Figure B): Use hole ⑥ for multi-core cable. Use hole ⑤ for grounding cable.

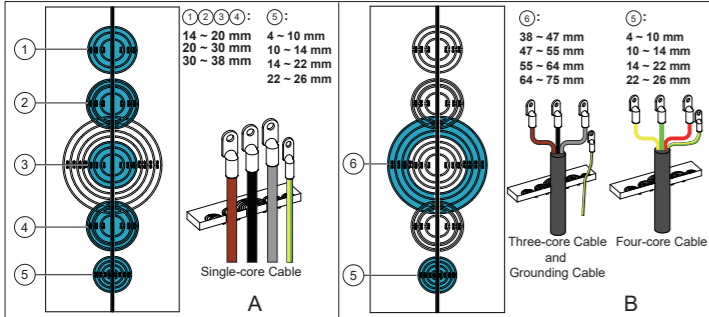

6. Remove the pre-installed M12 taper washer combination nuts from the AC terminal block. Connect the crimped terminal to the corresponding AC terminal stud, securing it with an M12 flat washer and M12 taper washer combination.

Note: Use OT/DT copper compression lugs for L1, L2, L3 copper wires. Use DTL Cu-Al bimetallic compression lugs for L1, L2, L3 aluminum wires.
Note: M12 flat washer shall be used if inner hole diameter of compression lug is >14mm; while it's unnecessary if inner hole diameter is ≤14mm.

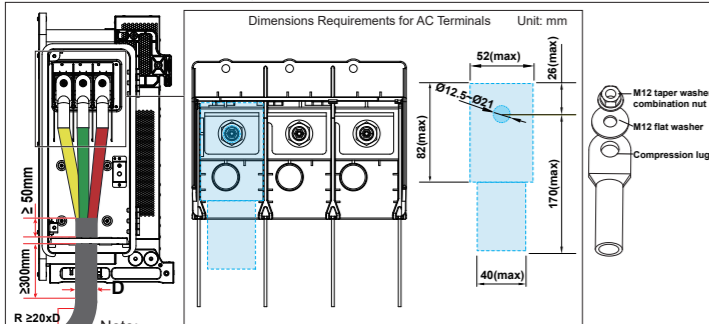

Note:
The wire stripping position should be ≥ 50mm higher than the bottom of wire box.
The cable outside the rubber pads should be vertical for at least 300mm.
The cable's bending radius (R) must be greater than or equal to 20 times the diameter (D) to prevent breakage due to excessive stress.

7. Place the two rubber pads back onto the wire box in their initial orientation. Torque: 3.5 N·m.

8. Adjust the cable position to ensure the cables are fully enclosed by the rubber holes. Then, unhook the support rod, close the side cover, and tighten the screws.

The inverter's rated output voltage is 800 V. Connect a transformer compatible with this voltage, following system-specific requirements below.

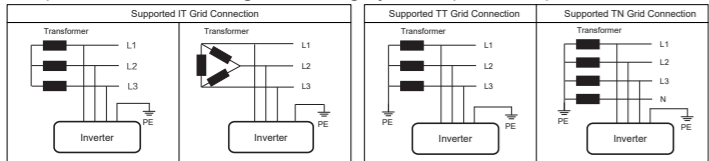

For IT power grid, neutral point at transformer low-voltage side is not grounded. PID or SVG functions can be enabled, but do not enable PidNight and SVG functions at the same time. For TT or TN power grid, neutral point at transformer low-voltage side shall be grounded. Enable only the SVG function and do not enable the PID function.

3.4 DC Wiring

1. Remove an appropriate length of the jacket and insulation layer from the DC input cable of PV strings.

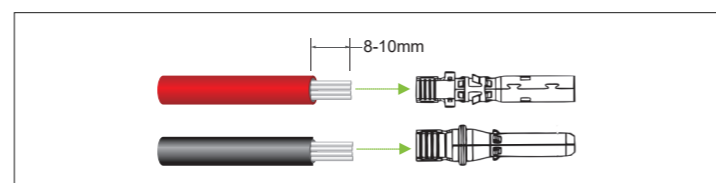

2. Insert the exposed areas of the positive and negative power cables into the metal terminals of the positive and negative connectors respectively and crimp them using a professional crimping tool, such as Amphenol H4TC0002 Devalan D4ZCY001.

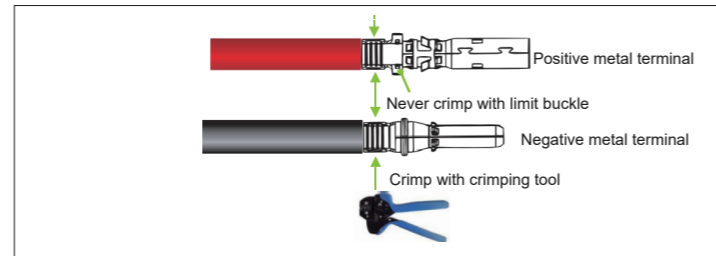

3. Insert the crimped positive and negative power cables into corresponding positive and negative connectors until a "click" sound is heard. Tighten the locking nuts of the positive and negative connectors.

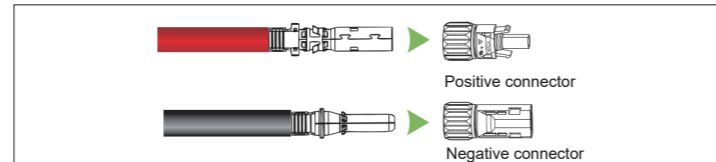

4. Measure the PV strings with a multi-meter to ensure the polarities of the DC input power cables are correct and the maximum open-circuit voltage does not exceed 1500 V (≤ 1500 V).

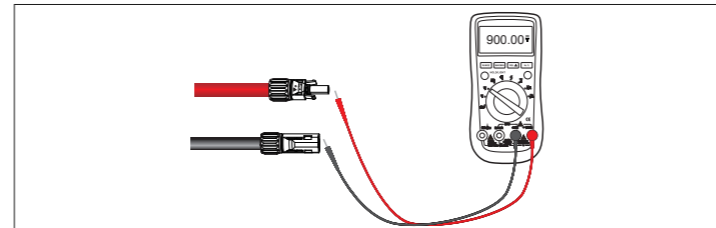

5. Insert the positive and negative connectors into their corresponding terminals of the inverter until a "click" sound is heard.

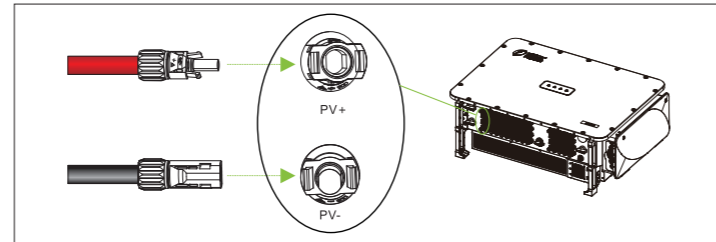

- NOTICE**
- Before making DC connections, ensure the DC switches are in the "OFF" state.
 - Make marks on all positive and negative power cables to identify their correct strings (such as PV1+, PV1-, PV2+, PV2-). Make sure all strings are connected to corresponding ports according to port names printed on the device, to avoid wrong connection. Otherwise, it may result in device damages or property loss.
 - Do not use Y-type PV connectors.
 - Distribute PV strings evenly across all MPPTs. Do not connect 5 strings to one MPPT if any other MPPT has fewer than 3 strings or is unloaded.
 - Prioritize connecting PV strings to the first four PV terminals of each MPPT (PV1-PV4, PV6-PV9, PV11-PV14, PV16-PV19, PV21-PV24, and PV26-PV29). Use the fifth PV terminal of each MPPT (PV5, PV10, PV15, PV20, PV25, and PV30) only if the total number of strings exceeds 24.
 - Ensure all PV strings connected to the same MPPT use solar panels of the same model, quantity, tilt angle, and azimuth angle.
 - The PV3 terminal must be connected.
 - Seal unused PV terminals with waterproof caps.

3.4 Communication Connection (Optional)

1. Install the 8-Pin Connector

(1) Unscrew the locking nut ① of 8-pin connector and press down both buckles ② of connector to separate the cable seal ring and the crimping plug from the adaptor.

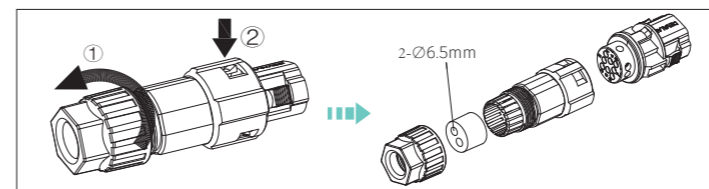

(2) Route cable through locking nut, seal ring and adaptor. Remove an appropriate length of the jacket and insulation layer from communication cable.

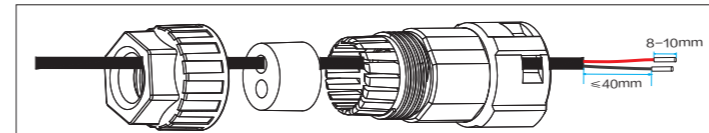

(3) Connect RS485 and/or CAN cables to correct crimping ports according to their definitions.

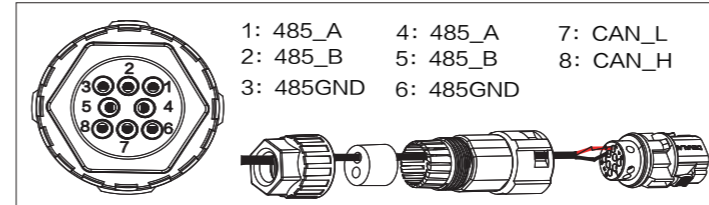

(4) Adjust the cable length, insert crimping plug (1) into adaptor and lock the locking nut (2). Plug any spare seal hole with watertight plug (3).

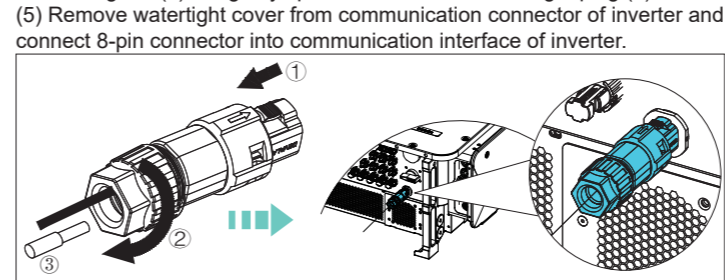

2. RS485 Network Connection

In an RS485 daisy-chain network with multiple inverters, if the last inverter is more than 200 meters (but not exceeding 1000 meters) from the data logger, enable the RS485 function in the MatriCloud App for the last inverter to improve RS485 communication quality.

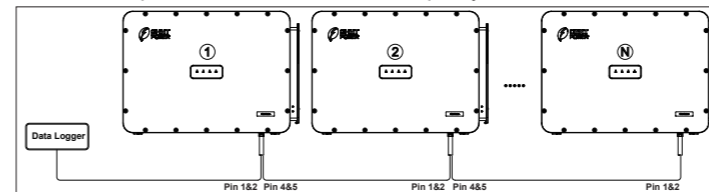

To enable the RS485 in the MatriCloud App, go to "Settings" > "LCDLess Parameters", set the "RS485TermResEn" parameter to "enable".

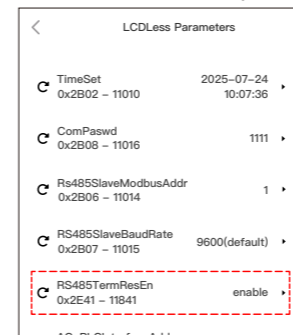

- NOTE**
- After completing all wiring steps:
- Secure the front cover by tightening all screws to prevent water ingress.
 - It is recommended to bind the cables approximately 300 mm to 350 mm away from the DC connectors and AC connector (refer to the figure below). This can help prevent swaying or movement of the cables, which may loosen the connectors and potentially affect the protection degree of the inverter.

4. Display



LED Icon	Name	Status	Indication
COM (Green)	Communication Indicator	On	Communication is normal
		Flash	Bluetooth communication active
		Off	No communication
RUN (Green)	Grid Operation Indicator	On	Grid-connected power generation
		Flash	Derated operation (on for 0.5 seconds, off for 1.6 seconds)
		Off	Other operating state or no power supply
GRID (Green)	Grid Status Indicator	On	Grid is normal
		Flash	Grid is abnormal (on for 0.5 seconds, off for 1.6 seconds)
		Off	No power supply
FAULT (Red)	Fault Status Indicator	On	Permanent failure
		Slow Flash	Alarm (on for 0.5 seconds, off for 2 seconds)
		Fast Flash	Protection mode (on for 0.5 seconds, off for 0.5 seconds)
		Flash	Protection mode (on for 0.5 seconds, off for 0.5 seconds)
		Off	No fault or no power supply
All lights flash			Upgrade (on for 0.05 seconds, off for 0.3 seconds)

5. Commissioning

WARNING Before PV system is powered on, it's important to check installation and wiring for any potential hazards.

1. Confirm that the positive and negative polarities of PV3 are correctly connected and measure its voltage > 600V.
2. Rotate the auxiliary switch to **ON** and confirm that any panel indicator lights up within 5 minutes.
3. Close all DC switches, then rotate the auxiliary switch to **OFF**.
4. Close the AC circuit breaker between the inverter and the grid, and confirm the **RUN** indicator stays on to complete grid connection.
5. Scan the QR code to download the MatriCloud App (supports Android 8.0 or higher and iOS 13.0 or higher).
6. Enable the phone's Bluetooth function, launch the MatriCloud App, and follow the setup instructions below.
 - ① Click the "Device Access".
 - ② Click the "Bluetooth Connect" to display available devices.
 - ③ Select "XXXXXXXX" (the last 8 digits of the device's S/N) to pair.
 - ④ Upon successful connection, the App will enter the home interface. Here you can view basic real-time information of the inverter like PV, DC, AC. You may also manually power the inverter ON/OFF using the button at the top-right corner of the interface.
 - ⑤ Click "More" on the home interface, then select "Basic Setting" and enter password "1111".
 - ⑥ Configure basic parameters including grid connection rule, rated voltage, PV input mode in compliance with national electrical codes and safety regulations.
 - ⑦ Click "Settings" to configure the parameters. **Note:** Register parameters must be modified according to the communication protocol under the guidance of the engineer.
 - ⑧ If a fault occurs, click the red alert text on home interface to check the fault details. Clear the fault using the troubleshooting list in user manual. After clearing the fault, restart inverter. If the issue continues, contact customer service.

