

Grid-tied PV Inverter
User Manual
SCH250/275K-T2-EU
SCH333/350K-T2-EU



Shanghai Chint Power System Co., Ltd.

Table of Contents

0	Preface	4
1	IMPORTANT SAFETY INSTRUCTIONS	5
1.1	Warnings and Symbols in this Document	5
1.2	Markings on the Product	6
1.3	Safety Precautions of Operating the PV Inverter	7
2	General Introduction	8
2.1	Photovoltaic Grid-tied System	8
2.2	Product Dimensions and Appearance	9
2.3	LED Display	10
2.4	Product Protection Functions	11
2.5	Schematic Diagram and Circuit Design	12
3	Mechanical Installation	13
3.1	Storage before Unpacking	13
3.2	Unpacking for Inspection	14
3.3	Installation Precautions	15
3.4	Installation Requirements	17
3.4.1	Installation Environment Requirements	17
3.4.2	Installation Modes Requirements	18
3.4.3	Recommended Clearances	19
3.5	Installation Procedures	20
4	Electrical Connection	23
4.1	Cable Specification	23
4.2	Tools Required and Torque Values	24
4.3	External Interfaces and Internal Connection Points	24
4.4	Electrical Cable Connection	25
4.4.1	Grounding(Protection Earthing)	26
4.4.2	AC Wiring	27
4.4.3	DC Wiring	31
4.5	Communication Connection	35
4.5.1	RS485 Cable Connection	35
4.5.2	RS485 Network Connection	37
5	Inverter Commissioning	38
5.1	Pre-commissioning Checks	38
5.1.1	Mechanical Installation Check	38
5.1.2	Electrical Connection Checks	38
5.2	Inverter Commissioning Steps	38
6	App Interface Overview and Setup	39
6.1	App Download	39
6.2	App Connection and Configuration	39
6.3	Main Function Configuration	47

6.3.1	Trip Monitoring (Detachment Board Monitoring).....	47
6.3.2	PID/SVG.....	51
7	Maintenance and Replace	53
7.1	Check Electrical Connections	53
7.2	Clean the Air Vent Filter	53
7.3	Replace the Cooling Fans	54
7.4	Replace the Inverter.....	56
8	Troubleshooting	57
8.1	LED Indicator Troubleshooting	57
8.2	Common Fault and Troubleshooting.....	57
9	Technical Data	63
10	Quality Assurance	65
10.1	Liability Exemption	65
10.2	Quality Clause (warranty Clause).....	66
11	Recycling	67

0 Preface

Thank you for choosing a Chint Grid-tied PV Inverter (hereinafter referred to as “PV Inverter” or “Inverter”) developed by Shanghai Chint Power System Co., Ltd. (hereinafter referred to as “CHINT”).

This PV Inverter is a high performance and highly reliable product specially designed for the EU market except North America solar market.



IMPORTANT!

Please read this manual carefully and make sure that you have understood all the contents thoroughly before you start any operation.

Main Contents

This Installation and Operation manual contains important information, safety guidelines, detailed planning and setup information for installation, as well as information about configuration, operation and troubleshooting. Be sure to read this manual carefully before using.

Target Readers

- Plant owner
- Project Engineer
- Installation engineer
- Maintenance engineer

Installation, commissioning, troubleshooting, and maintenance of the inverter must be done only by qualified personnel. If you encounter any problems during the above-mentioned operation, please check the user manual carefully. You can also contact your local dealer or supplier for help if the problem still exists.

Manual Management

Please keep this user manual on hand for quick reference.

Copyrights

CHINT reserves all rights in this manual. Any reproduction, disclosure or copy in whole or in part is forbidden without prior written authorization. CHINT doesn't accept any responsibilities whatsoever for potential errors or possible lack of information in this document.

Version





This manual is subject to change or modification without prior notice. Users can get the latest manual from our sales channel or our official website: www.chintpower.com.

1 IMPORTANT SAFETY INSTRUCTIONS







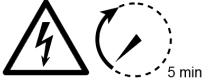

(SAVE THESE INSTRUCTIONS)

PLEASE READ THIS USER MANUAL CAREFULLY BEFORE THE INSTALLATION AND OPERATION OF THIS PV INVERTER. CHINT POWER RESERVES THE RIGHT TO REFUSE WARRANTY CLAIMS FOR EQUIPMENT DAMAGE IF USERS FAIL TO INSTALL THE EQUIPMENT ACCORDING TO THE INSTRUCTIONS IN THIS MANUAL. FAILURE TO FOLLOW THESE INSTRUCTIONS AND OTHER RELEVANT SAFETY PROCEDURES MAY RESULT IN VOIDING OF THE WARRANTY AND/OR DAMAGE TO THE INVERTER OR OTHER PROPERTY!

1.1 Warnings and Symbols in this Document

Symbols	Meanings
	<p>DANGER! DANGER indicates a hazardous situation with high level of risk which, if not avoided, will result in death or serious injury.</p>
	<p>WARNING! WARNING indicates a hazardous situation with medium level of risk which, if not avoided, could result in death or serious injury.</p>
	<p>CAUTION! CAUTION indicates a hazardous situation with low level of risk which, if not avoided, could result in minor or moderate injury.</p>
	<p>NOTICE! NOTICE indicates a hazardous situation which, if not avoided, could result in equipment working abnormally or property loss.</p>
	<p>IMPORTANT! INSTRUCTION indicates important supplementary information or provides skills or tips that can be used to help you solve a problem or save you time.</p>

1.2 Markings on the Product

Symbols	Meanings
	HIGH VOLTAGE! This equipment works with high voltages. All works on the equipment must only be performed as described in this document.
	HIGH ENERGY! Risk of electric shock from energy stored in capacitor. Do not remove cover until 5 minutes after disconnecting all sources of supply.
	HOT SURFACE! Hot surfaces. To reduce the risk of burns. Do not touch.
	For more details please see the user manual.
	WARNING! For continued protection against risk of fire, replace only with same type and ratings of fuse. Refer to instruction manual for details.
	EARTH GROUND! This symbol marks the location of a grounding terminal, which must be securely connected to the earth through the PE (protective earthing) cable to ensure operational safety.
	RoHS SYMBOL In accordance with 2011/65/EU regulations, the inverter imposes restrictions on the use of specific hazardous substances in electrical and electronic equipment.
	Certification CE This inverter has passed CE Certification.
	Certification TÜV The safety and quality of the inverter have been certified by TÜV Rheinland.
	The effective service life of the inverter casing is 20 years.

1.3 Safety Precautions of Operating the PV Inverter

WARNING!



All operations and connections shall be performed by professional engineering and technical personnel!

To prevent the risk of electric shock during equipment maintenance or installation, please ensure that all DC and AC power has been separated from the equipment, and ensure that the equipment is reliably grounded.

DANGER!



Before opening the inverter housing for maintenance, you must first disconnect the grid-side AC power supply and PV-side DC power supply, and ensure that the high-voltage energy inside the equipment has been completely released!

Generally, you must cut off all connections to the inverter for at least 5 minutes before you can maintain and operate the equipment.

NOTICE!



The inverter is specially designed to integrate the generated AC power into the public grid. Do not directly connect the AC output terminal of the device to private AC power equipment. The inverter does not support battery panel grounding. If grounding is necessary, a transformer must be added to the AC side.

NOTICE!



Please do not install the inverter in a place exposed to direct sunlight, so as not to reduce the conversion efficiency due to high temperature and to ensure the long-term service life of the inverter.

CAUTION!



Please check the mounting bracket again before hanging up to make sure that the mounting bracket is firmly installed on the supporting surface.

For continued protection against risk of fire, replace only with same type and ratings of fuse. Disconnect supply before changing fuse.

IMPORTANT!



Before choosing a power grid code, please contact your local power supply company. If the inverter is set to work under the wrong grid regulations, the power supply company may cancel the operation permit of the equipment.

Please ensure that the entire system complies with national standards and applicable safety regulations before running the inverter.

2 General Introduction

2.1 Photovoltaic Grid-tied System

SCH250/275/320/333/350K-T2-EU series inverters are designed for using with commercial rooftop, and large-scale PV grid-tied systems. The system is generally made up of PV modules, PV inverter and AC power distribution equipment, as shown in Figure 2-1. The solar energy is converted by PV modules to DC power, and then converted by the inverter to AC power with the same frequency and phase as the AC grid. Now the AC power can be supplied in all or in part to local loads, with the remaining power fed to the grid.



Figure 2-1 Grid-tied PV system

Table 2-1 Components of Grid-tied PV system

Item	Name	Description
A	PV Module	Monocrystalline, polycrystalline silicon components, non-ground batteries
B	PV Inverter	SCH250/275/320/333/350K-T2-EU
C	Metering device	Standard metering device for inverter power generation
D	Public Grid	Support IT system, TT system, and TN system

2.2 Product Dimensions and Appearance

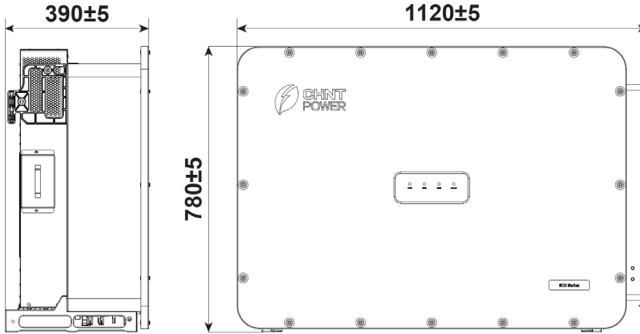

Figure 2-2 Inverter Dimensions (Unit: mm)

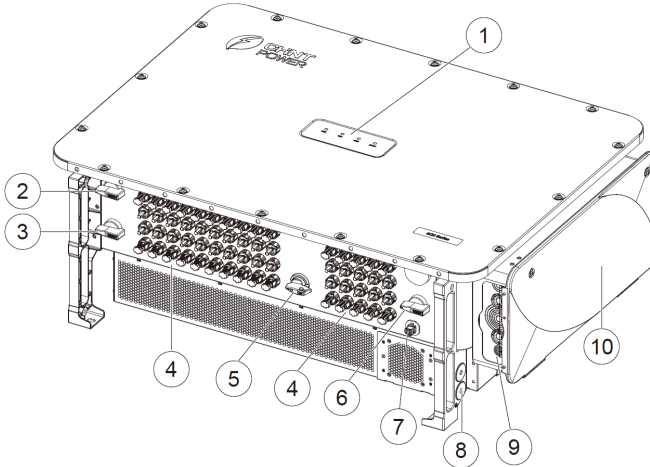

Figure 2-3 Product Appearances

Table 2-2 Product Components

No.	Name	Function
1	LED Indicator	Indicates operation status of the inverter
2	DC Switch	Control PV 1~10
3	DC Switch	Control PV11~20
4	PV String Terminal	Quick plug terminal connector
5	Auxiliary Switch	For internal power supply of inverter
6	DC Switch	Control PV 21~30
7	Communication Interface	Connect 8-pin connector
8	External Grounding Hole	External grounding
9	Rubber Pad for AC Outlet	AC and internal grounding cable outlet port
10	AC Wire Box	For AC wiring

2.3 LED Display

LED display of the inverter is shown as follows:



Figure 2-4 LED display of the inverter

Indicators and their indications are shown in Table 2-3.

Table 2-3 4 LED Indicators and their indications

LED Icon	Name	Status	Meaning
COM (Green)	Communication Indicator	On	Communication is normal
		Flash	Bluetooth communication active
		Off	No communication
RUN (Green)	Grid Operation Indicator	On	Grid-connected power generation
		Flash	Derating operation status (on for 0.5 seconds, off for 1.6 seconds)
		Off	Other operating state or no power supply
GRID (Green)	Grid Status Indicator	On	Grid is normal
		Flash	Grid is abnormal (on for 0.5 seconds, off for 1.6 seconds)
		Off	No power supply
FAULT (Red)	Fault Status Indicators	On	Permanent failure
		Slow Flash	Alarm (on for 0.5 seconds, off for 2 seconds)
		Fast Flash	Protection mode (on for 0.5 seconds, off for 0.5 seconds)
		Off	No fault or no working power supply
All lights flash Flash			Upgrade status (on for 0.05 seconds, off for 0.3 seconds)

2.4 Product Protection Functions

- **Electrical Connection & Wiring Protection**
 - AC Short-Circuit Protection
 - DC Reverse Connection Protection
 - DC Input and AC Output Overcurrent Protection
- **Grid & Voltage Protection**
 - Grid Monitoring / Output Voltage & Frequency Monitoring
 - Anti-island Protection
 - DC Input & AC Output Overvoltage Protection
 - Surge Protection
- **Grounding & Insulation Protection**
 - Leakage Current Protection / Ground Fault Monitoring
 - Input-to-ground Insulation Resistance Monitoring
 - DC Component Monitoring of Output Current
- **Component & Temperature Monitoring**
 - Internal Ambient Temperature Monitoring
 - Module Temperature Monitoring
- **Other Functions**
 - PID Prevent and Recovery

2.5 Schematic Diagram and Circuit Design

The electrical schematic diagram of inverter is as shown in Figure 2-5. PV input goes through the lightning protection circuit and DC EMI filter circuit and then through the previous BOOST circuit to achieve maximum power tracking and boost functions. The inverter uses three-level technology to convert the DC voltage into a three-phase AC voltage, filters out high frequency components through an output filter, and then outputs high-quality AC power through a two-stage relay and an EMI filter.

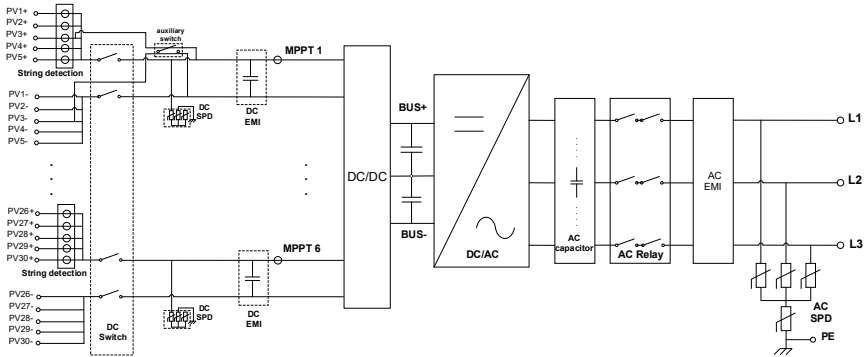

Figure 2-5 Schematic Diagram

3 Mechanical Installation

3.1 Storage before Unpacking

If the inverter is not immediately installed upon arrival, the following requirements should be met when storing the inverter:

- Do not remove the outer packing of the inverter.
- Store it in a clean, dry place to prevent dust and moisture intrusion.
- During the storage period, regular inspections are necessary (it is recommended to check at least once every three months). If packing damage is detected, replace the packaging materials promptly.
- Keep the packing box away from corrosive substances to avoid damaging the inverter casing.
- If the inverter has been stored for more than 1 year, perform a comprehensive inspection and test by professional personnel before putting it into operation.
- Do not stack multiple inverters beyond the "Stacking Limit" indicated on the outer packing.

Note: Any damage to the inverter caused by improper storage is not covered by the warranty.

3.2 Unpacking for Inspection

Before unpacking, check whether the packaging box and all safety signs, warning labels, and nameplates on the packaging box and the product are intact. These signs must always be clearly visible and cannot be removed or covered until the product is scrapped. Before performing installation, check the product for any obvious damages or if the items on the delivery list are complete. Contact your supplier if any problem is found. The delivery list is as below:

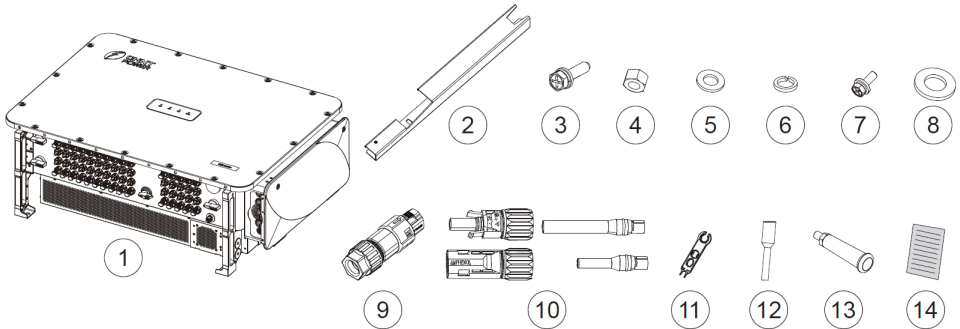

Figure 3-1 Delivery List

Table 3-1 Accessories Description

No.	Item	Qty	Usage
1	PV Inverter	1	N/A
2	Mounting Bracket	2	For mounting bracket
3	Screw M10x50	4	
4	Nut M10	4	
5	Flat Washer M10	6	4 for mounting bracket 2 for securing inverter
6	Spring Washer M10	4	For mounting bracket
7	Screw M6x18	2	Secure inverter and support structure
8	Flat Washer M12	3	Secure AC terminal block
9	8-Pin Connector	1	Communication cable connection
10	DC Input Male (+) Connector	30	PV quick connector
10	DC Input Female (-) Connector	30	
11	Unlock tool for DC Connector	1	Unlock connector

No.	Item	Qty	Usage
12	Plug Rod	1	Plug seal ring of 8-pin connector
13	Handle	2	Carry the inverter
14	Document	1	Quick Installation Guide

3.3 Installation Precautions

- Check that the product environmental specifications (protection degree, operating temperature range, humidity and altitude, etc.) meet the requirements of the specific project location.
- Make sure that the power grid voltage is within the normal range of the Grid Code chosen. Ensure that you have been authorized by the local electricity supply authority to connect to the grid.
- Installation personnel must be qualified electricians or those who have received professional training.
- Wear and use proper PPE (personal protective equipment) during installation.
- Sufficient space must be provided to allow the inverter cooling system to operate normally.
- Install the inverter away from flammable and explosive substances, and prohibit old, sick, disabled people and children from approaching.
- The equipment should be installed in an area far away from liquids; It is strictly prohibited to install it below water pipes, air vents, and other locations that are prone to condensation; It is strictly prohibited to install below the air conditioning outlet, ventilation outlet, machine room outlet window, and other locations that are prone to water leakage, to prevent liquid from entering the equipment and causing equipment malfunction or short circuit.
- When installing, if drilling is required, please make sure to avoid the water and electricity wiring inside the wall.
- Make sure the installation condition doesn't exceed the temperature limits specified for the inverter, to prevent undesirable power loss.
- Do not install the inverter near an electromagnetic source which can compromise the normal operation of electronic equipment.
- The characteristics of salt mist are easily affected by factors such as seawater, sea breeze, precipitation, relative humidity, terrain, and forest range near the coast. Therefore, inverters should not be installed outdoors in salt affected areas (within 500m from the coast).
- The inverter may generate noise during operation, please do not install it in a place that affects daily life.
- The installation height of the inverter should be easy to observe the LED indicator panel, as well as facilitate electrical connection, operation, and maintenance.
- The PV Array is not grounded (floating).

- The bottom power and communication interfaces of the inverter should not bear any weight, and should not be directly in contact with the ground.
- Static electricity may damage the electronic components of the inverter, so anti-static measures should be taken during the replacement or installation process.
- Each inverter must be equipped with an AC circuit breaker and should not be shared among multiple inverters.
- Reverse engineering, decompiling, disassembling, dismantling, modifying, implanting, or any other derived operations on the device software are strictly prohibited. It is also prohibited to study the internal implementation of the device, obtain the device software source code, steal intellectual property rights, or disclose any performance testing results of the device software.
- If the gap of the output terminal is not blocked according to the requirements, resulting in machine failure, our company does not carry out warranty, and bear any responsibility.
- Cables of the same type should be bundled together, and different types of cables should be arranged separately, with no intertwining or crossing allowed.
- Under no circumstances should the device structure, installation sequence, or any other aspect be modified without the permission of the manufacturer.

For detailed specification ranges and limits, see **Chapter 9**.

3.4 Installation Requirements

3.4.1 Installation Environment Requirements

It is recommended to install inverter under a shelter or sunshade to avoid direct sunlight, rain and snow accumulation, to prevent from triggering power derating, increasing inverter failures or reducing its service life.

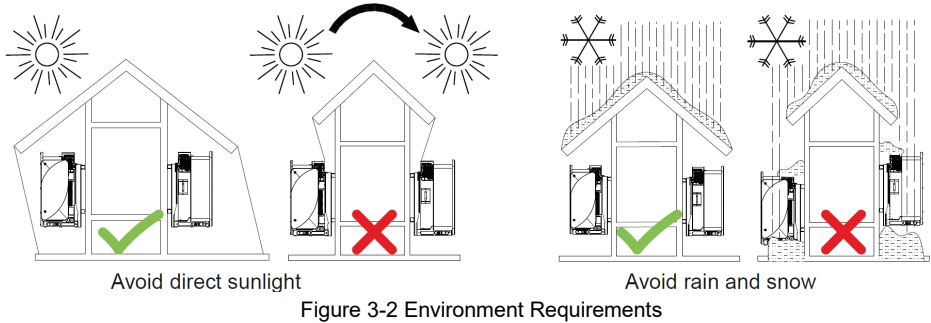

NOTE!

Wall installation is not permitted.

If using a sunshade (user-supplied), the recommended installation space between the sunshade and the inverter is as follows:

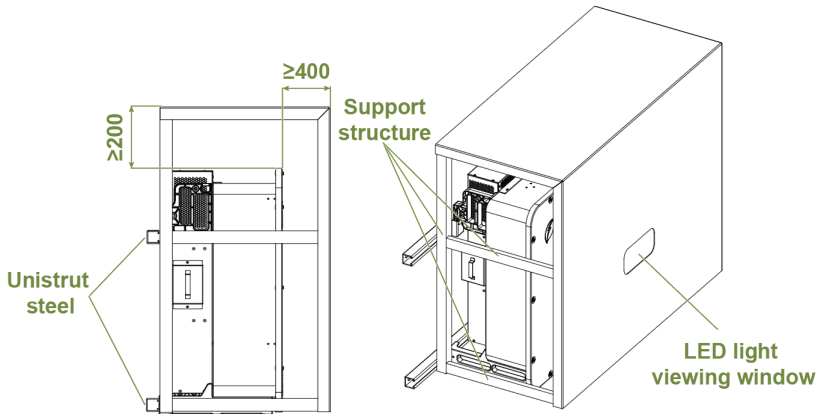

Figure 3-3 Sunshade Installation Recommendations (Unit: mm)

3.4.2 Installation Modes Requirements

Allowed Installation Modes:

- (A). If the location permits, install the inverter vertically.
- (B). If the inverter cannot be mounted vertically, it may be tilted backward by less than 15° from vertical.
- (C). The inverter can be installed under the PV panel, while its back and top shall not be blocked to ensure good ventilation.
- (D). The inverter can be installed on a single-column mounting pole, and shall be checked to confirm a secure installation.

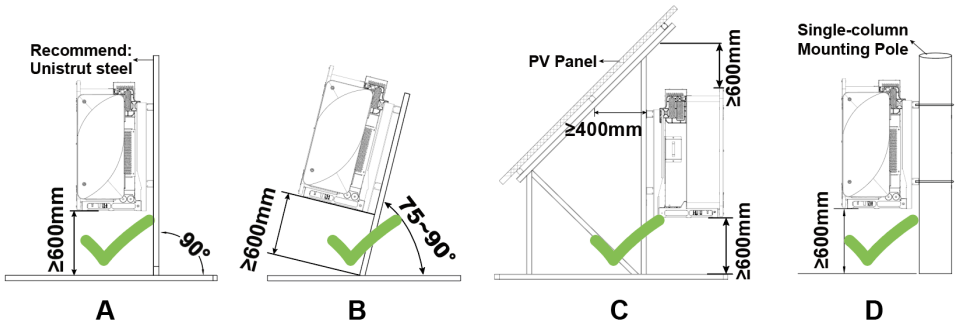

Figure 3-4 Allowed Installation Modes

Not Allowed Installation Modes

- (A). Do not mount the inverter leaning forward.
- (B). Do not mount the inverter upside down.
- (C). Do not mount the inverter horizontally.
- (D). Do not mount the inverter directly on a wall.

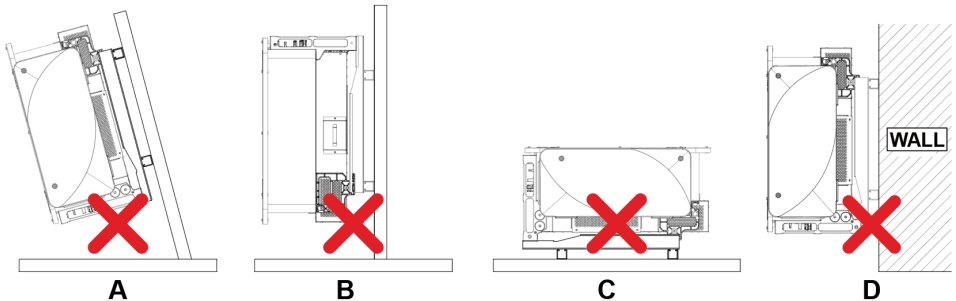

Figure 3-5 Not Allowed Installation Modes

3.4.3 Recommended Clearances

During planning and installing the inverter, appropriate clearances shown as below shall be reserved to ensure enough ventilation and heat dissipation. If the inverters are installed in relatively enclosed space, this clearance shall be increased properly to maintain well ventilated condition. In addition, no objects shall be put in-between two inverters to prevent any negative influences on heat dissipation.

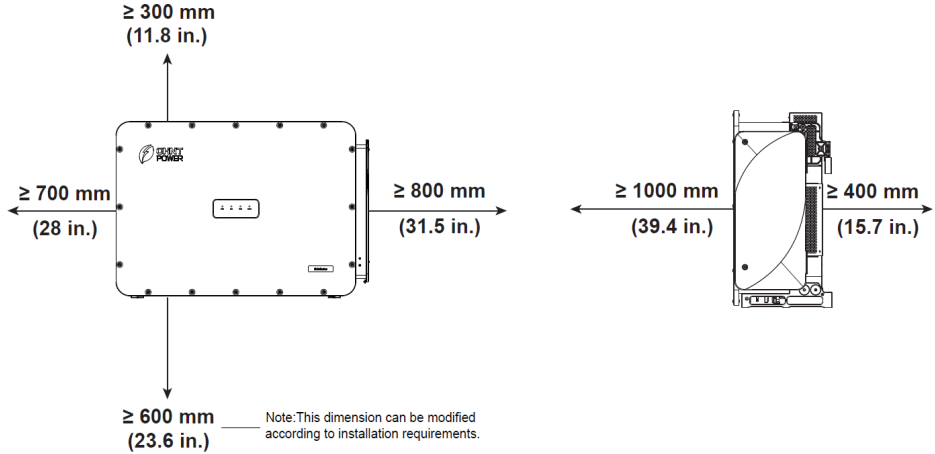

Figure 3-6 Recommended Clearances

3.5 Installation Procedures

1. Mark the drilling points on the support structure (offered by customer) according to the mounting hole positions and the size of the mounting bracket.

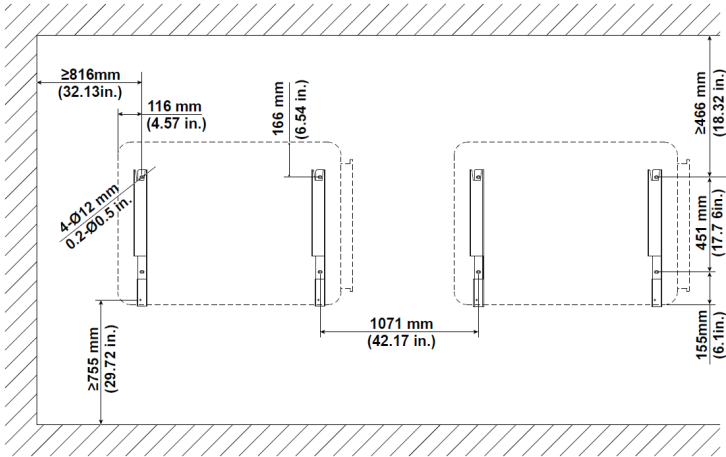

Figure 3-7 Hole Position Dimensions of Multiple Mounting Brackets

2. Drill holes at the marked positions using a drill. Secure the mounting bracket (5) to the support structure (6) using the M10x50 screws (1), M10 flat washers (2), M10 spring washers (3), and M10 nuts (4).

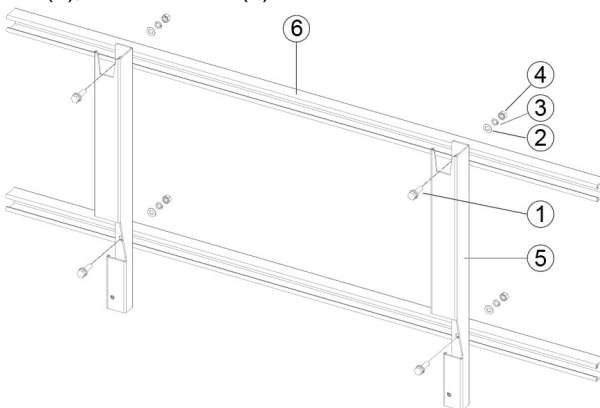

Figure 3-8 Install the Mounting Bracket



CAUTION!

To prevent dust from entering the respiratory system or getting into the eyes during drilling, operators should wear protective goggles and dust masks.

3. Hang the inverter onto the mounting bracket using one of the following methods:
 - (A). Machine Hoisting (preferred): Tighten two M12 lifting eyebolts (offered by customer) into the screw holes as indicated. Use sling rope or bar (inserted through both lifting eyebolts) to lift the inverter and hang it onto the mounting bracket. Ensure the angle between the two sling ropes is less than 90 degrees.

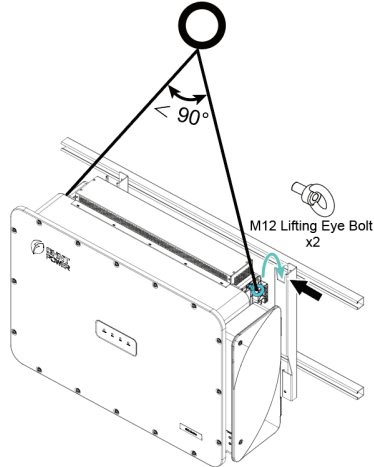

Figure 3-9 Machine Hoist

- (B). Manual Lifting: Install two M12 handles into the threaded holes. With four personnel: grip the fixed bottom handles (hollow-centers) and two M12 handles. Lift and hang the inverter onto the mounting bracket.

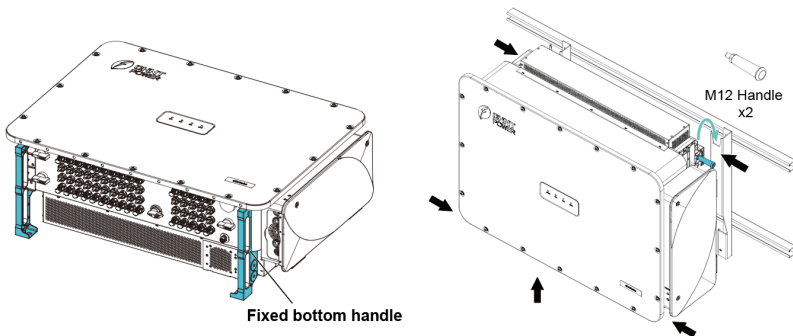

Figure 3-10 Manual Lifting

CAUTION!



The total weight of the inverter is approximately 127 kg (280 pounds). Confirm that the mounting bracket is securely installed on the support structure before hanging the inverter. It is recommended to have at least four operators to handle the inverter. When handling the inverters, pay attention to maintain balance to prevent them from tipping or falling.

- Secure the inverter to the mounting structure using the M6x18 screws and M10 flat washers.
Tools: 17mm hexagon socket wrench, torque: 6 N·m.

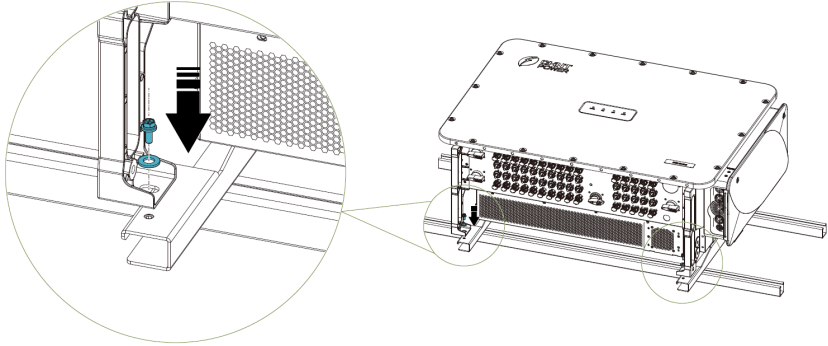

Figure 3-11 Secure the Inverter on the Mounting Structure

4 Electrical Connection

DANGER!



- The cables shall be connected in accordance with the National Electrical Code and all other applicable local codes or jurisdictions.
- Before connecting all cables, ensure the equipment is free from any damage. Otherwise, it may cause electric shock or fire.
- High-temperature environments may result in insulation aging or damage of cables. The distance between the cables and heat-generating devices or the surrounding area of the heat source should be at least 30mm.
- Before performing any electrical connection, make sure both DC and AC switches are OFF. Otherwise, fatal injury can occur due to high voltage.

4.1 Cable Specification

Cable	Type	Cable Outer Diameter (mm)	Conductor CSA (Cross-sectional area) (mm ²)
DC Cable	PV cables that meet 1500V standard	5.0~7.2 ^{*a}	4~6
AC Cable ^{*b}	Outdoor single-core copper/ aluminum wire	14~38	L1, L2, L3: 120~400 PE: ≥ CSA of phase wire conductor /2
	Outdoor three-core copper/ aluminum wire	38~75	
	Outdoor four-core copper/ aluminum wire		
PE Cable	Outdoor copper wire	N/A	Same with AC cable PE.
Communication Cable	Communication cable UTP CAT-5e	4.5~6	3 x 0.2~0.75
	Shielded twisted pair		3 x 1~1.5

Note *a: For selection exceeds the given range, please consult CHINT for feasibility.

Note *b: Do not directly connect aluminum-wire AC cables to the AC terminal block.

Table 4-1 Cable specifications

4.2 Tools Required and Torque Values

Table 4-1 Tools Required and Torque Values

No	Tools	Usages	Torque
1	5mm hex. wrench	Open and close the wire box side cover	3.5 N·m
2	No.19 hex. socket wrench	Fix AC output terminal	40 N·m
3	No.10 hex. socket wrench	Fix internal and external grounding terminals	23 N·m
4	1.5mm flat-blade screwdriver	Fix RS485 and CAN terminals	0.2 N·m
5	Diagonal pliers	Cut cables	N/A
6	Wire stripper	Strip wires	N/A
7	Crimping Tool	Crimp cables	N/A

4.3 External Interfaces and Internal Connection Points

You will find the external connection interfaces, internal connection points, as well as their names, positions etc. as shown in the following figures.

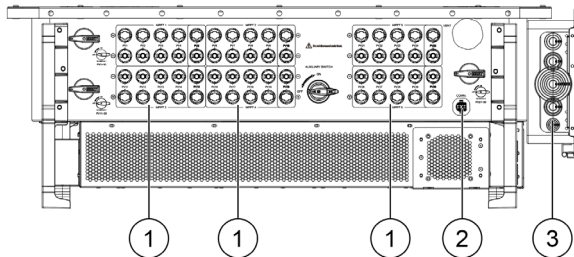

Figure 4-1 External Connection Interfaces

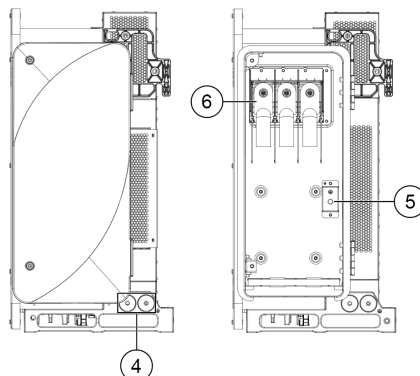

Figure 4-2 External grounding point and AC Wiring terminal block

Table 4-2 External Interfaces and Internal Connection Points

No.	Names
1	DC Input (male & female) quick-plug connector
2	Communication interface
3	AC cable outlet
4	External grounding point (PE point)
5	Internal grounding point
6	AC Output terminal block

4.4 Electrical Cable Connection

NOTICE!

Please read carefully and refer to Chapter 9 Technical Data before wiring. Ensure inverter cover is securely closed and attached after wiring is completed to avoid water condensation inside unit.



Before the first power-on operation or before running inverter after a long period of non-operation (6-12 months), check if the water-sensitive label in the bottom left corner of the AC wire box and on the capacitive plate have turned red. Never power on the inverter if any water-sensitive label has turned red. Never damage or tamper with the vent valve.

WARNING!

Make sure all DC and AC power has been disconnected before opening the wire box and ensure that hazardous high voltage and power has been discharged to avoid risk of electric shock.



Wait at least 5 minutes before opening the wire box.

Wiring preparation:

- Loosen the two screws (a) on the wire box to open the side cover. Store the screws safely; if lost, use the two spare screws (b) pre-installed on the wire box.

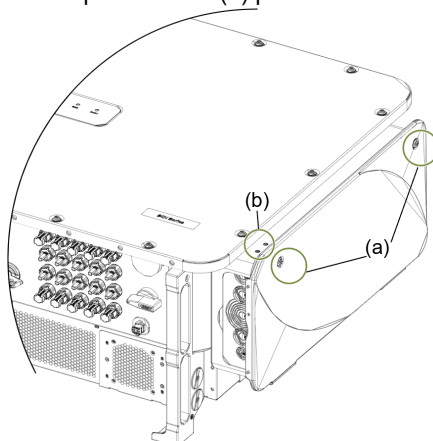

Figure 4-3 Open side cover of AC wire box

- Remove the support rod from the side cover and hook it into the cover's hole to support the cover.

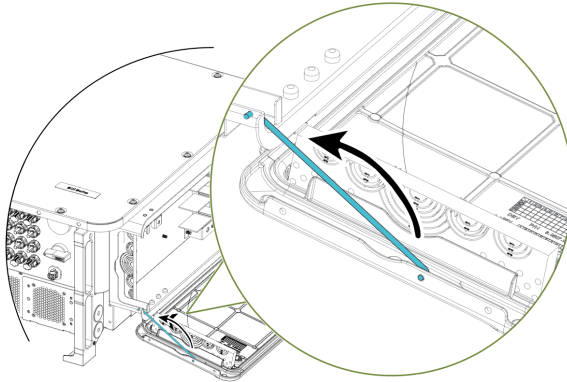

Figure 4-4 Support the Side Cover

4.4.1 Grounding(Protection Earthing)

The grounding cable must be connected using at least one of the following methods:

- Internal grounding: A grounding hole is located inside the AC wire box. One M10x25 screw is pre-installed in this hole and is used to secure the grounding terminal.
- External grounding: Two grounding holes are located on the machine's exterior near the bottom of the AC wire box. Two M10x25 screws are bundled inside the wire box and are used to secure the grounding terminal.

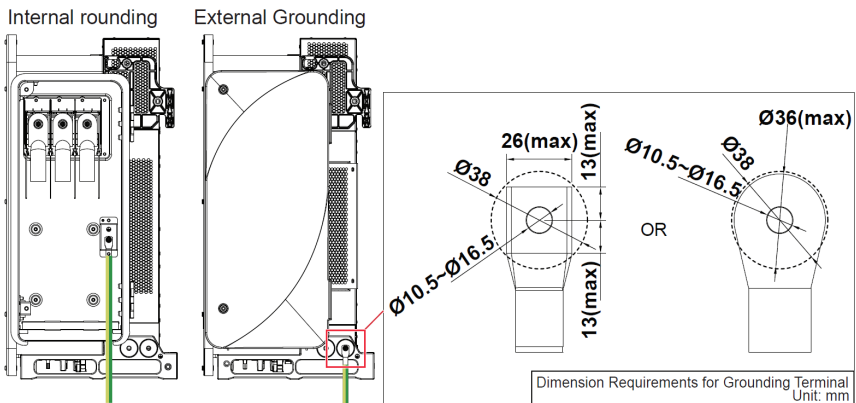

Figure 4-5 Grounding Methods

4.4.2 AC Wiring

Perform the AC wiring procedures as follows:

1. Remove the two rubber pads from the wire box side cover by hand. Note their initial orientation for wiring and reinstallation.

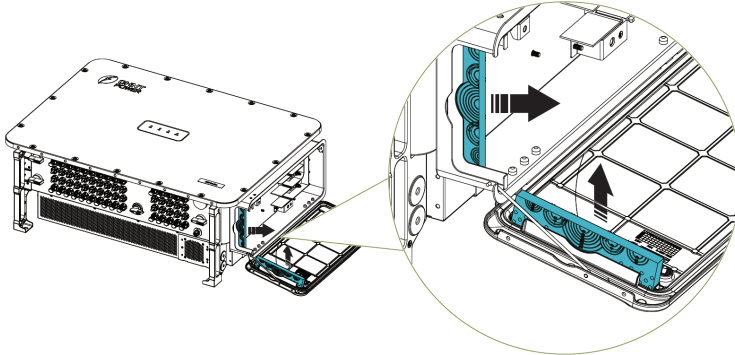

Figure 4-6 Remove Rubber Pads

2. Strip an appropriate length of the jacket and insulation layer from the AC cable, insert the exposed core wires into the terminal crimping area, and crimp it with hydraulic pliers. Insulate the crimped area with heat-shrink tubing or insulating tape. (Note: Wrap the wire crimp area with heat shrink tubing or insulation tape.)

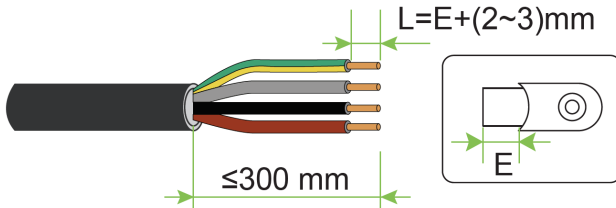

Figure 4-7 Prepare cable



NOTE!

For copper-core cable, use OT/DT copper compression lugs
For aluminum-core cable, use DTL CU-AI bimetallic compression lugs.

3. Based on the AC cable type, select the matching aperture size and pull the aperture open using hand or pliers. The rubber pad has five cable holes:
- Single-core cable (See Figure A): Use any three of holes ① , ② , ③ , or ④ for L1/L2/L3 cable. Use hole ⑤ for grounding cable.

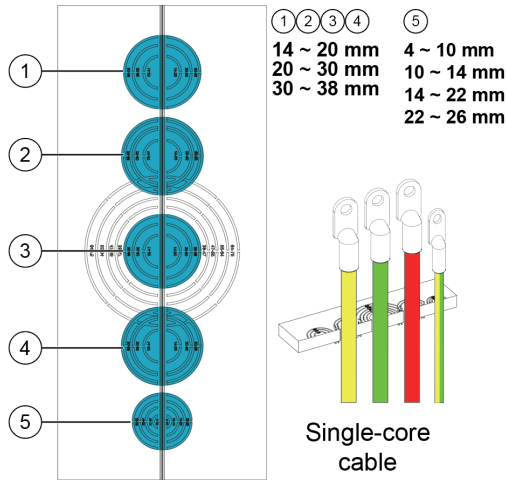

Figure 4-8 Single-core Cable Routing

- Multi-core cable (See Figure B): Use hole ⑥ for multi-core cable. Use hole ⑤ for grounding cable.

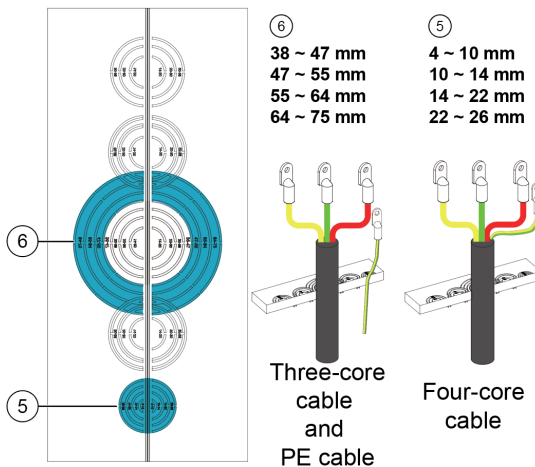

Figure 4-9 Multi-core cable Routing

- Remove the pre-installed M12 taper washer combination nuts from the AC terminal block. Connect the crimped terminal to the corresponding AC terminal stud, securing it with an M12 flat washer and M12 taper washer combination.

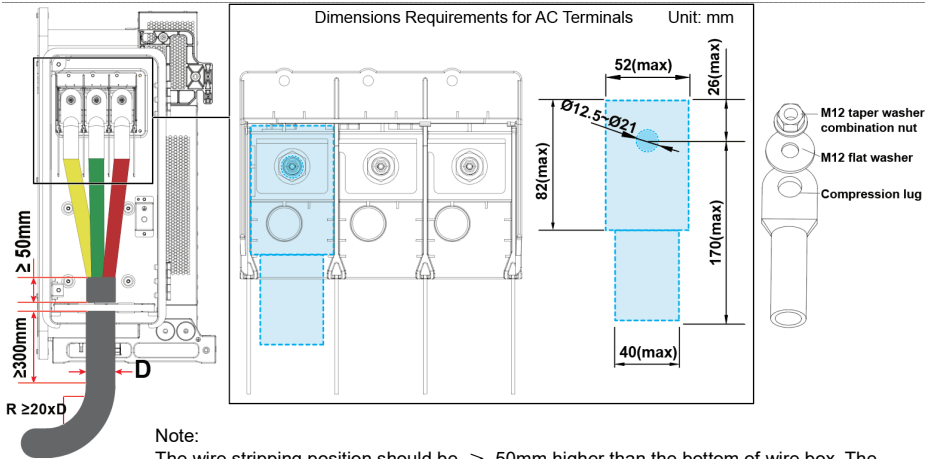

Figure 4-10 Connect AC cable to AC terminal block



NOTICE!

M12 flat washer shall be used if inner hole diameter of compression lug is $>14\text{mm}$; while it's unnecessary if inner hole diameter is $\leq 14\text{mm}$.

- Place the two rubber pads back onto the wire box in their initial orientation.
- Adjust the cable position to ensure the cables are fully enclosed by the rubber holes. Then, unhook the support rod, close the side cover, and tighten the screws.

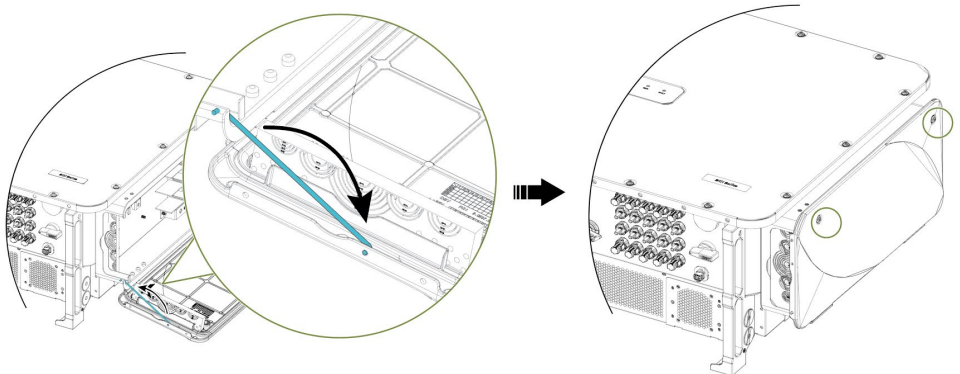

Figure 4-11 Recover side cover of AC wire box

The inverter's AC nominal operating voltage is 800VAC. If another voltage/configuration is needed, a transformer may be necessary.

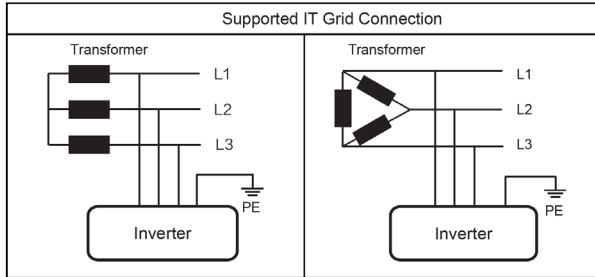

Figure 4-11 Supported IT power grid

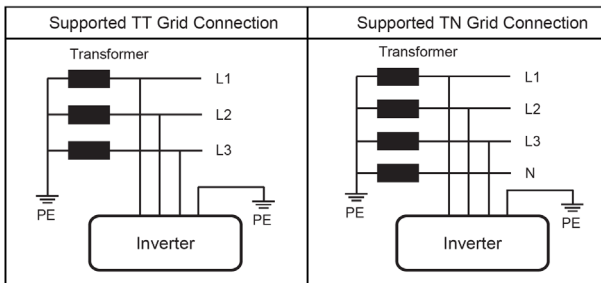

Figure 4-12 Supported TT and TN power grid

Transformer configurations: 3W Wye and 4W Wye are recommended. 3W Delta Configuration is acceptable, but the Delta can't connect with ground as following Figure. Other configurations are incompatible with SCH250/275/333/350K-T2-EU, such as those shown in figure 4-13:

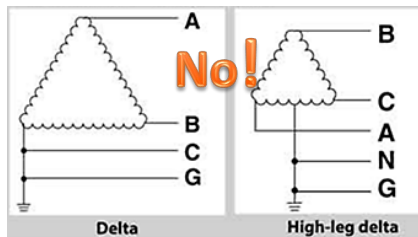

Figure 4-13 Incompatible Configurations

IMPORTANT!



The inverter is only compatible with Wye Floating and Delta Floating transformer winding configurations. External AC Ground Fault detection is required by code NEC 2017/2020 Section 250.21 when inverters are connected to Wye Floating or Delta Floating transformer windings. The inverter will provide DC Ground Fault detection

4.4.3 DC Wiring

4.4.3.1 DC Cable Connection

To ensure the optimum performance of the inverter, please read the following guidelines before performing any DC connections:

- Confirm the DC configuration and ensure that the maximum open circuit voltage of the PV modules is lower than 1500VDC under any conditions;
- Check the polarity before terminating the DC cables of PV strings according to the following steps, as shown in figure below:
 - i. Use a multi-meter to measure the PV strings' cable ends and check the polarity.
 - ii. The positive (+) terminal of cable should match the positive (+) terminal of inverter's DC input.
 - iii. The negative (-) terminal of cable should match the negative (-) terminal of inverter's DC input.

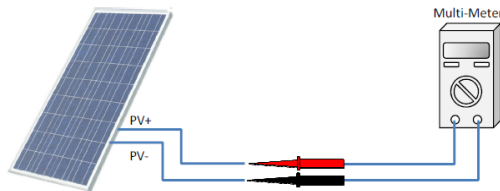

Figure 4-14 Polarity Check



NOTICE!

It is important to use a multi-meter to check the polarity of the DC input cables to avoid any risk of reverse polarity.

Perform cable connection as per the following steps:

1. Remove an appropriate length of the jacket and insulation layer from the DC input cable of PV strings.

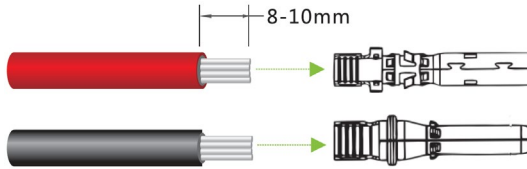

Figure 4-15 DC Wire stripping

2. Insert the exposed areas of the positive and negative power cables into the metal terminals of the male and female connectors respectively and crimp them using a crimping tool (Amphenol H4TC0002 or Devalan D4ZCY001).

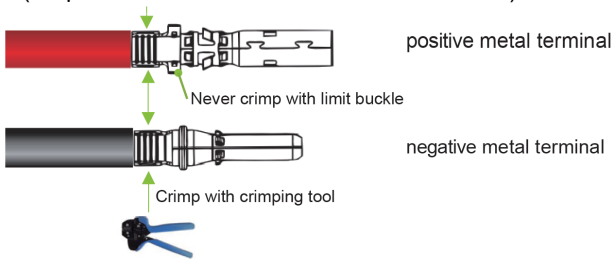

Figure 4-16 Crimp Power Cables



NOTICE!

The positive and negative DC input metal terminals and connectors must use those provided with the product or the same model from the same manufacturer. Using other types may result in poor contact and affect normal operation.

3. Insert the crimped positive and negative power cables into the corresponding male and female connectors until a "click" sound is heard.

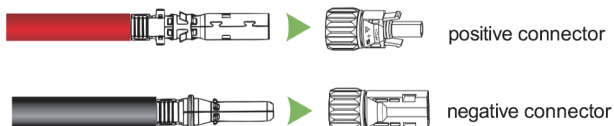

Figure 4-17 Insert Power Cables to Connectors



NOTICE!

The grounding wire must be connected well.
The DC switch should be in the OFF state.

4. Measure the cable ends of PV strings using a multi-meter to ensure the polarities of

the DC input power cables are correct and the maximum open-circuit voltage does not exceed 1500 V (≤ 1500 V).

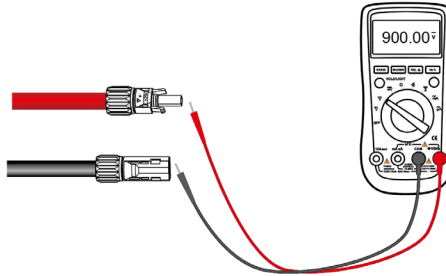

Figure 4-18 Verify the Polarities of the DC Cable

5. Insert connectors into the corresponding terminals of the inverter until a "click" sound is heard.

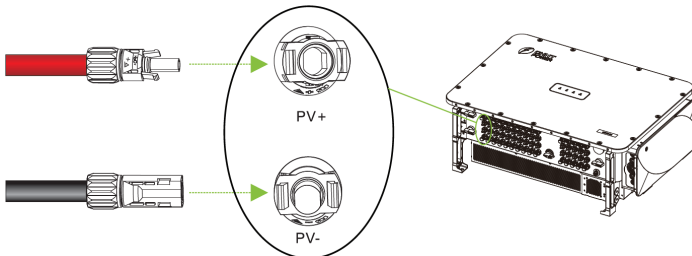

Figure 4-19 Insert DC Connectors into Corresponding PV Terminals

NOTICE!

- (C). Before making DC connections, ensure the DC switches are in the "OFF" state.
- (D). Make marks on all positive and negative power cables to identify their correct strings (such as PV1+, PV1-, PV2+, PV2-). Make sure all strings are connected to corresponding ports according to port names printed on the device, to avoid wrong connection. Otherwise, it may result in device damages or property loss.
- (E). Do not use Y-type PV connectors.
- (F). Distribute PV strings evenly across all MPPTs. Do not connect 5 strings to one MPPT if any other MPPT has fewer than 3 strings or is unloaded.
- (G). Prioritize connecting PV strings to the first four PV terminals of each MPPT (PV1–PV4, PV6–PV9, PV11–PV14, PV16–PV19, PV21–PV24, and PV26–PV29). Use the fifth PV terminal of each MPPT (PV5, PV10, PV15, PV20, PV25, and PV30) only if the total number of strings exceeds 24.



-
- (H). Ensure all PV strings connected to the same MPPT use solar panels of the same model, quantity, tilt angle, and azimuth angle.
 - (I). The PV3 terminal must be connected.
 - (J). Seal unused PV terminals with waterproof caps.
-

After completing all wiring steps, it is recommended to bind the cables approximately 300 mm to 350 mm away from the DC connectors and AC connector (refer to the figure below). This can help prevent swaying or movement of the cables, which may loosen the connectors and potentially affect the protection degree of the inverter.

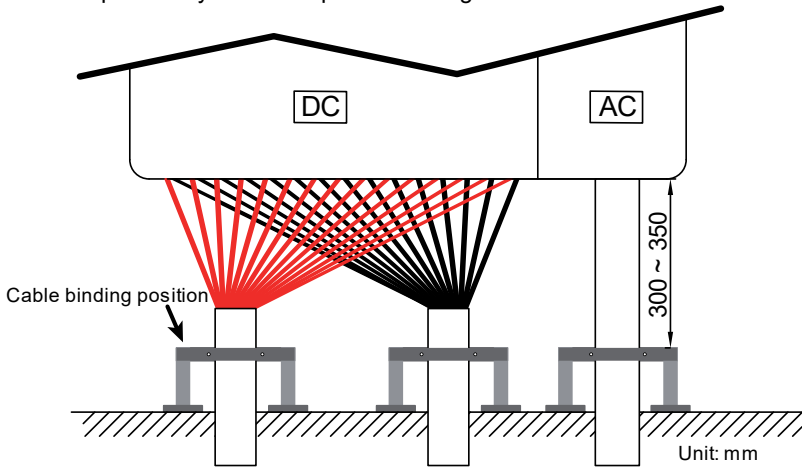

Figure 4-20 Bind cables

Unit: mm

4.5 Communication Connection

4.5.1 RS485 Cable Connection

1. Unscrew the locking nut ① of 8-pin connector and press down both buckles ② of connector, to take out the cable seal ring.

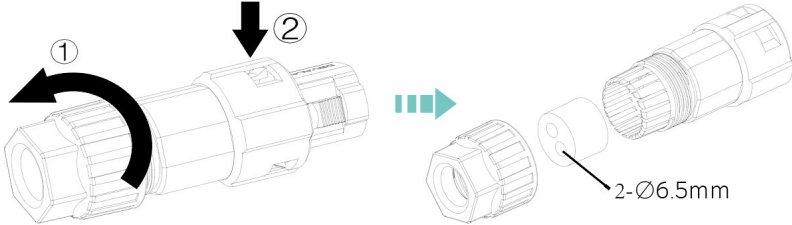

Figure 4-21 Take out the Cable Seal Ring

2. Route cable through locking nut, seal ring and connector. Remove an appropriate length of the jacket and insulation layer from communication cable.

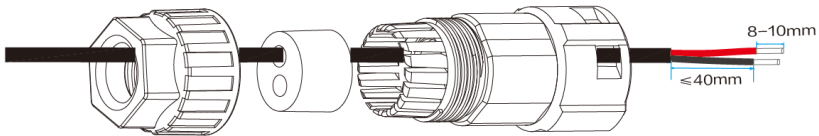
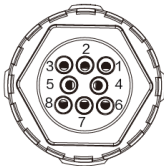

Figure 4-22 Route cable and Stripping

3. Connect RS485 and/or CAN cable to their terminal according to the definition of terminals block.



1: 485_A	4: 485_A	7: CAN_L
2: 485_B	5: 485_B	8: CAN_H
3: 485GND	6: 485GND	

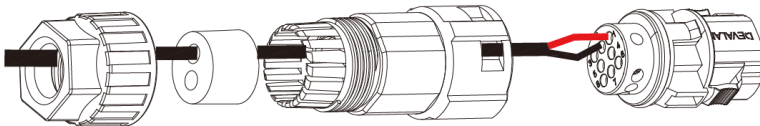

Figure 4-23 Connect RS485 and/or CAN Cable to their Terminal

- Adjust the cable length, insert terminals block ① into connector and lock the locking nut ②. Plug any spare sear hole with watertight plug ③.

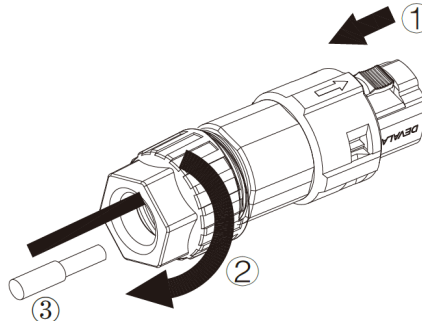

Figure 4-24 Combine the Connector

- Remove watertight cover from communication connector of inverter.

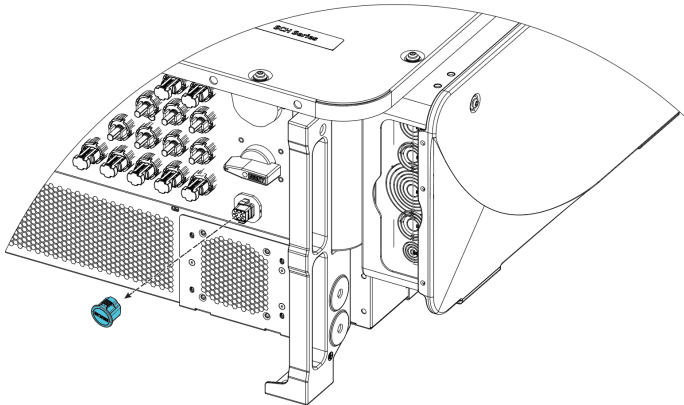

Figure 4-25 Remove watertight cover

- Connect 8-pin connector into communication interface of inverter.

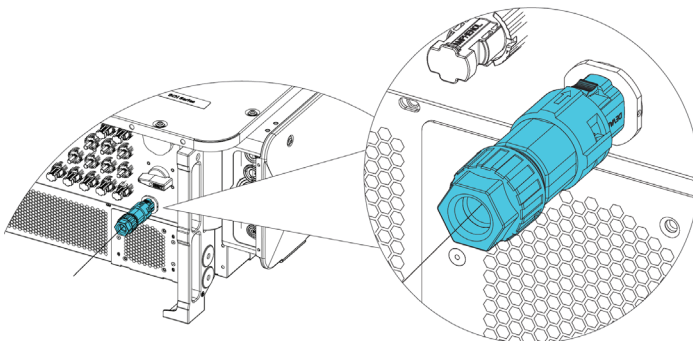

Figure 4-26 Connect 8-pin connector

4.5.2 RS485 Network Connection

In an RS485 daisy-chain network with multiple inverters, if the last inverter is more than 200 meters (but not exceeding 1000 meters) from the data logger, enable the RS485 function in the MatriCloud App for the last inverter to improve RS485 communication quality.

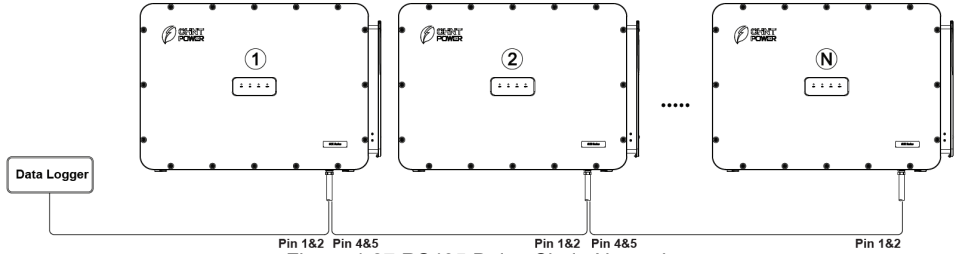

Figure 4-27 RS485 Daisy-Chain Network

To enable the RS485 in the MatriCloud App, navigate to **"Settings"** > **"LCDLess Parameters"**, set the **"RS485TermResEn"** parameter to **"enable"**. For details, refer to Chapter 6 App Interface Overview and Setup.

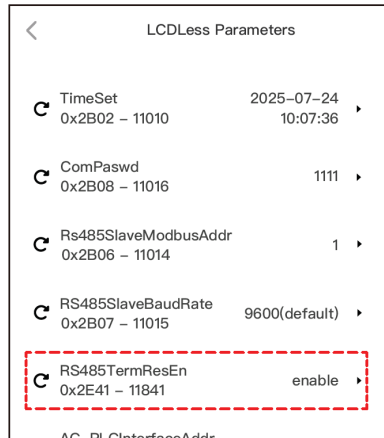

Figure 4-28 Enable RS485

5 Inverter Commissioning

5.1 Pre-commissioning Checks

5.1.1 Mechanical Installation Check

Refer to Section 3.5 Installation Procedures and perform the following checks:

- Verify that the support structure and mounting structure are stable and securely fixed
- Verify that all installation screws have been tightened to the specified torque values

5.1.2 Electrical Connection Checks

Refer to Chapter 4 Electrical Connection and perform the following checks:

- Confirm that all cables are connected firmly and reliably, with no incorrect or missing connections.
- The cables are routed and placed properly to prevent mechanically damage.
- Confirm that the positive and negative polarity of the DC cable on the input side is correct.
- Turn the DC Switch to the "OFF" position.
- Confirm that the AC circuit breaker is appropriately sized.
- Test and check that the AC-side voltage is within the normal operating range.
- Measure the DC-side open-circuit voltage of input strings to confirm it is $\leq 1500V$.

5.2 Inverter Commissioning Steps

Complete the test and inspection before operation. Confirm that there is no error.

Follow the steps below to test run the inverter.

1. Confirm that the positive and negative polarities of PV3 are correctly connected and measure its voltage $> 600V$.
2. Rotate the auxiliary switch to ON and confirm that any panel indicator lights up within 5 minutes.
3. Close all DC switches, then rotate the auxiliary switch to OFF.
4. Close the AC circuit breaker between the inverter and the grid, and confirm the RUN indicator stays on to complete grid connection.
5. Follow the setup steps in Chapter 6: App Interface Overview and Configuration to ensure the inverter's grid-tied function operates correctly.

6 App Interface Overview and Setup

NOTICE!



- The mobile phone should remain within a visible distance of 5 meters from the inverter; otherwise, the communication signal quality between the App and the inverter cannot be guaranteed.
 - This section provides a brief introduction to MatriCloud App operations. For more detailed steps about MatriCloud App, please refer to *MatriCloud Platform Mobile App: Local Operation Guide*.
-



6.1 App Download

Download the MatriCloud App from Apple Store (iOS) or Google Play (Android), or scan the QR code. Requires Android 7.0+ or iOS 13.0+.



6.2 App Connection and Configuration

After powering on the inverter, follow these steps to configure it using the App:

1. Ensure Bluetooth is enabled on your mobile phone and within effective range.
2. Launch the MatriCloud App, click  to select right server, and click  to select the language.

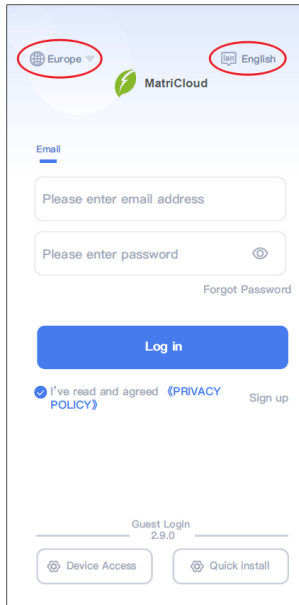

Figure 6-1 Configure Area and Language

(K). Click Bluetooth Connect to display available devices.

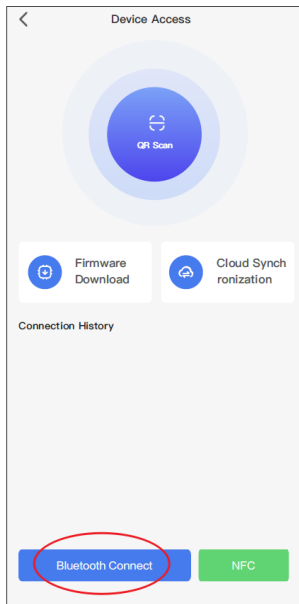

Figure 6-2 Click Bluetooth Connect

3. Select XXXXXXXX (the last 8 digits of the inverter's S/N) to pair.

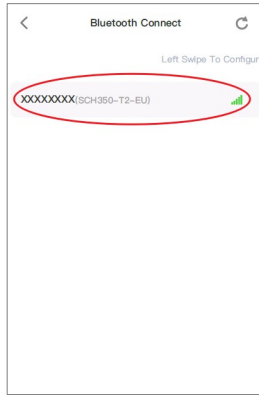

Figure 6-3 Select device to pair

- (L). Upon successful connection, the App will enter the home interface. Here you can view basic real-time information of the inverter like PV, DC, AC. You may also manually power the inverter ON/OFF using the button at the top-right corner of the interface.

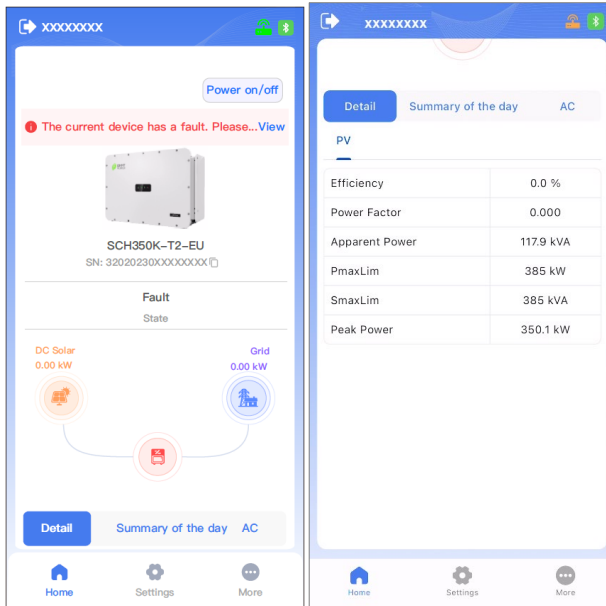

Figure 6-4 Home

4. Configure basic parameters including grid connection rule, rated voltage, PV input mode in compliance with national electrical codes and safety

5. Click More on the bottom navigation bar.



Figure 6-5 Click More

6. Select Basic Setting and enter password 1111.

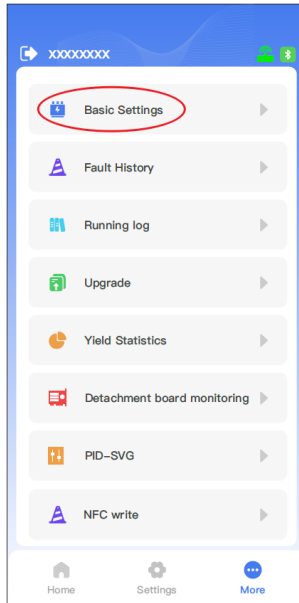

Figure 6-6 Basic Setting

7. Configure basic parameters including grid connection rule, rated voltage, PV input mode in compliance with national electrical codes and safety regulations.

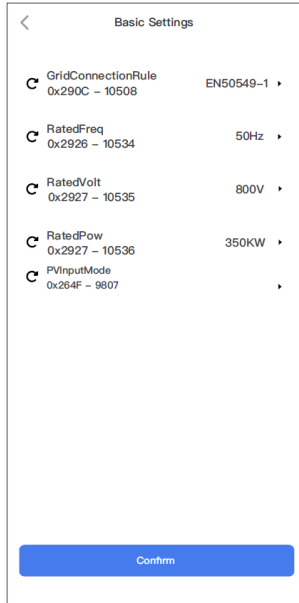
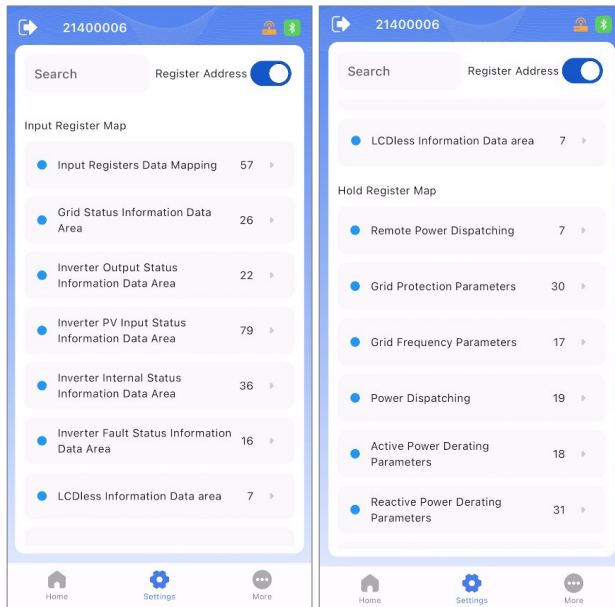

Figure 6-7 Configure basic parameters

8. Click Settings on the bottom navigation bar (If password needed, enter 1111) to access the register parameter configuration interface. Configure register parameters under engineering guidance. Parameters are grouped as follows:
 - Input Register Map (Only READ)
 - Input Registers Data Mapping
 - Grid Status Information Data Area
 - Inverter Output Status Information Data Area
 - Inverter PV Input Status Information Data Area
 - Inverter Internal Status Information Data Area
 - Inverter Fault Status Information Data Area
 - LCDless Information Data Area
 - Hold Register Map (READ and WRITE)
 - Remote Power Dispatching
 - Grid Protection Parameters
 - Grid Frequency Parameters
 - Power Dispatching
 - Active Power Derating Parameters
 - Reactive Power Derating Parameters

- High and Low Penetration Parameters
- Power On And Off Parameters
- Control Commands
- Others Function Parameters
- Important Parameters
- Inverter Basic Information
- PID Parameters
- Trip Protection Parameters
- Power Generation Data Area
- LCDLess Basic Information
- LCDLess Parameters



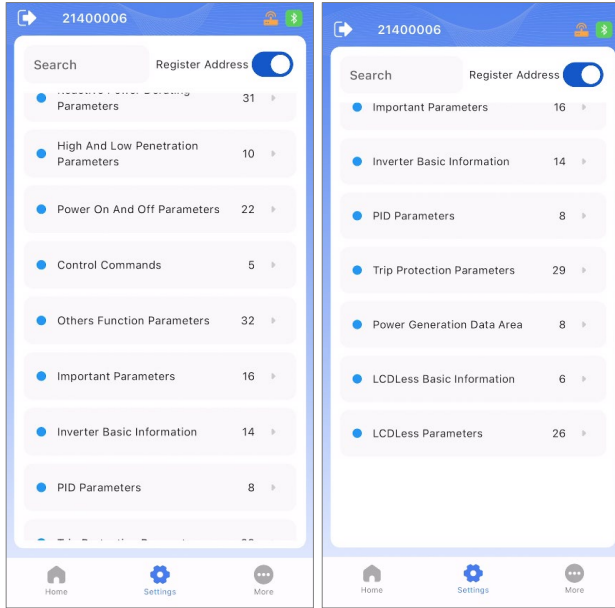

Figure 6-8 Configure Parameters

9. Power on/off operations are accessible through the following entry points:
(M). Home interface: Use the power on/off button in the upper-right corner;



Figure 6-9 Power on/off through Home interface

- (N). Settings menu: Navigate to Settings > Holding Register Parameters > Control Commands.

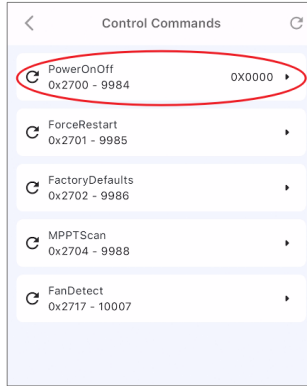

Figure 6-10 Power on/off through control commands

10. If a fault occurs, click the red alert text on home interface to check the fault details. Clear the fault using the troubleshooting list in this manual. After clearing the fault, restart inverter. If the issue continues, contact customer service.

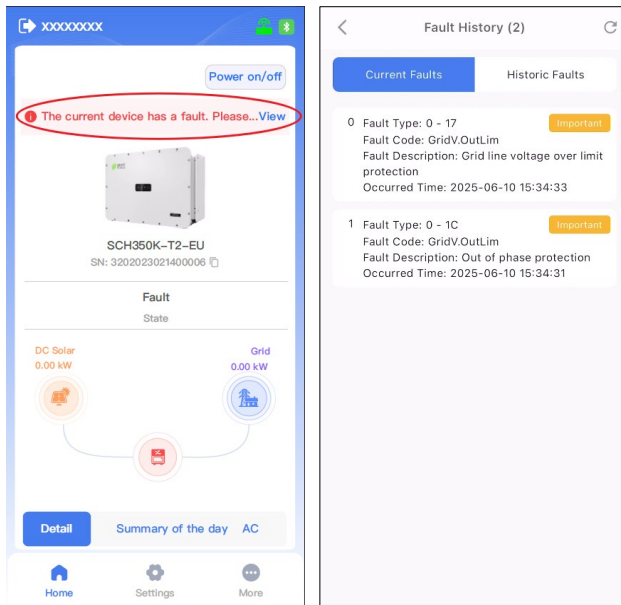

Figure 6-11 View fault log

6.3 Main Function Configuration

6.3.1 Trip Monitoring (Detachment Board Monitoring)

The trip board integrates functions such as reverse polarity/reverse power flow/short-circuit protection, IV scanning, and online upgrade.

Follow these steps to configure the trip protection monitoring function:

- (O). Navigate to More > Detachment Board Monitoring. The interface displays the software version, current communication status, enclosure humidity, wire temperature inside the enclosure, and the current status of the DC switches.

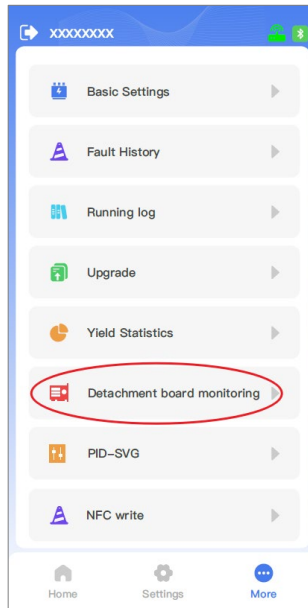

Figure 6-12 Enter Trip Protection Monitoring Interface

1. Click button in the upper-right corner of the Trip Monitoring screen to enable the trip unit monitoring function. This interface displays the software version, current communication status, internal enclosure humidity, and the status of the DC switch.

If the status bar shows "Tripped", it indicates that the DC switch has been disconnected. Click the "Reset" button, then manually close the DC switch to clear the fault.

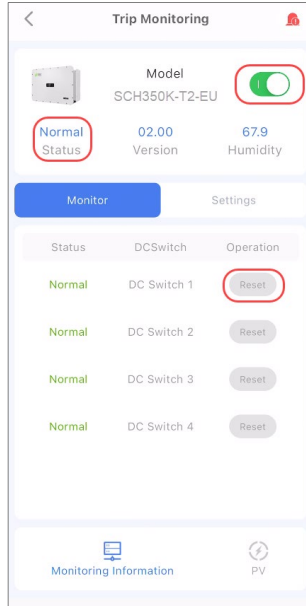

Figure 6-13 Enable Trip Monitoring

2. After enabling the trip monitoring function, click “Settings” to configure the threshold values for each trip protection feature.

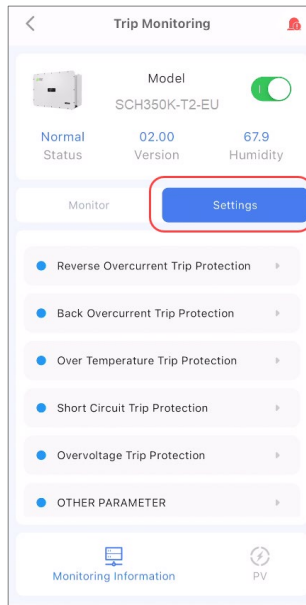

Figure 6-14 Configure Trip Protection Parameters – Entry Point 1

Additionally, you can configure trip protection parameters by navigating to **Settings > Trip Protection Parameters**.

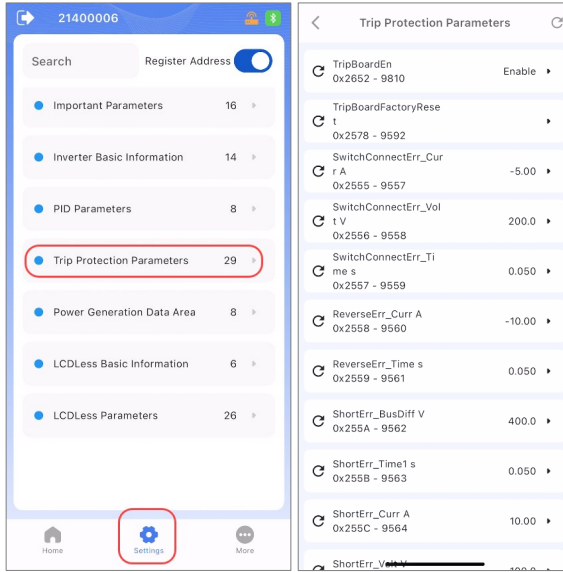

Figure 6-15 Configure Trip Protection Parameters-Entry Point 2

(P). Click **PV** to view the real-time voltage and current of each string.

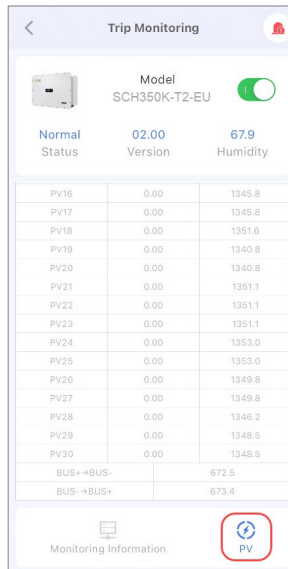

Figure 6-16 View Real-Time PV String Information

(Q). If a fault trip occurs, tap the alarm icon in the upper-right corner of the screen to view detailed fault information.

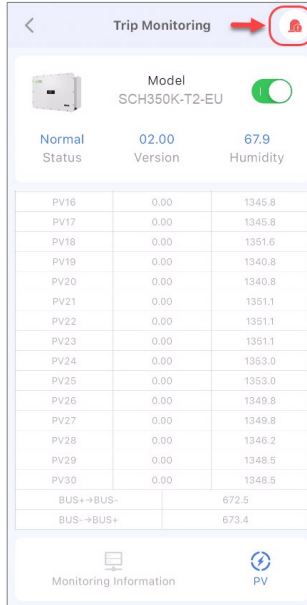

Figure 6-17 View Trip Fault Information

NOTICE!



- When the neutral point of the transformer is grounded, PID cannot be enabled.
- PV panel side (inverter DC input side) is energized when PidNight repair function is enabled. Therefore, before performing any maintenance or overhaul, disable the PidNight repair function and then wait at least 5 minutes to ensure the system is completely de-energized and to avoid electric shock.

6.3.2 PID/SVG

NOTICE!



- When the neutral point of the transformer is grounded, PID cannot be enabled.
- PV panel side (inverter DC input side) is energized when PidNight repair function is enabled. Therefore, before performing any maintenance or overhaul, disable the PidNight repair function and then wait at least 5 minutes to ensure the system is completely de-energized and to avoid electric shock.

Configure the PID and SVG Functions as follows:

1. Navigate to More > PID-SVG.

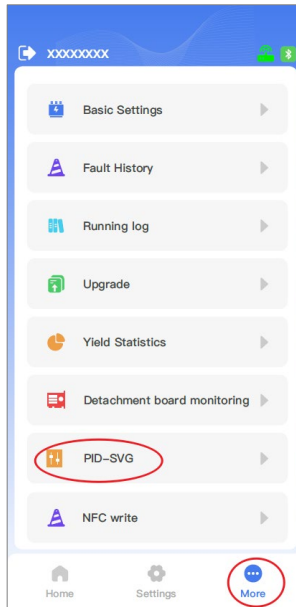

Figure 6-18 Enter PID/SVG Interface

2. Enable both PID and SVG functions, and configure key parameters such as PID system type (*PidSelectSystemType*) and SVG reactive power set value (*SvgReactiveSetVal*).

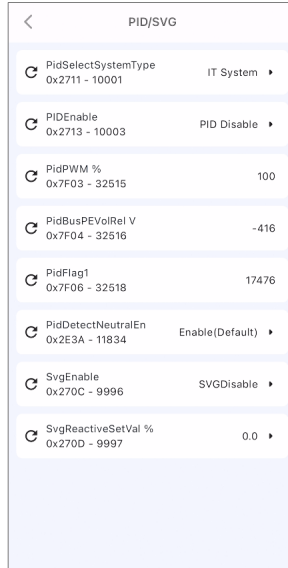

Figure 6-19 Configure PID-SVG Parameters – Entry Point 1

3. Additionally, you can configure PID parameters by navigating to "Settings" > "PID Parameters".

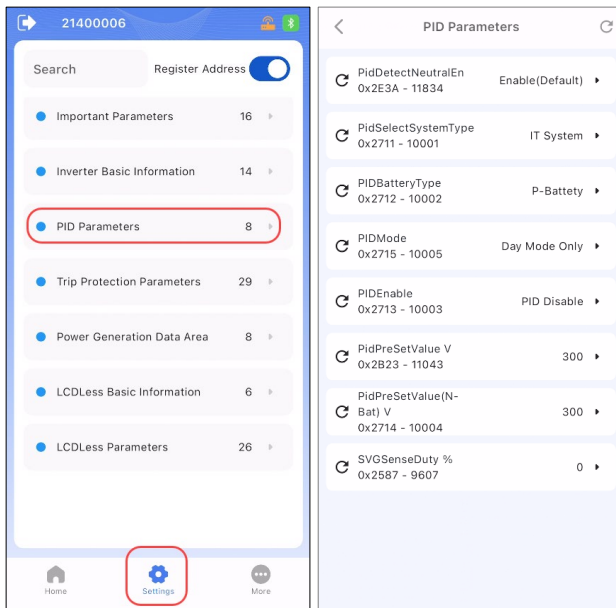

Figure 6-20 Configure PID-SVG Parameters – Entry Point 2

7 Maintenance and Replace

WARNING!



- Before starting any product maintenance, the inverter should be stopped running, the AC circuit breaker connected to the grid and the PV input on the DC side shall be all disconnected, and then wait at least 5 minutes before starting any operation.
 - These servicing instructions are for use by qualified personnel only.
 - To reduce the risk of electrical shock, do not perform other servicing other than those specified in the operation instructions unless you are qualified to do so.
-

7.1 Check Electrical Connections

Perform maintenance checks as a regular maintenance inspection on all inverter connection cables every 6 to 12 months:

- Check for any loose connections. Refer to Chapter 4 for instructions on tightening cables.
- Verify that the grounding cable is securely and properly connected to ground.
- Inspect all connection cables for damage, especially any signs of abrasion where cables may contact metal surfaces. Repair or replace as necessary.
- Check for cable damage, especially whether the cable surface is scratched or smooth. Repair or replace the cables if necessary.
- Check whether sealing plugs on unused DC input terminals are intact and properly in place.
- Ensure all unused terminals and ports are fitted with waterproof plugs.

7.2 Clean the Air Vent Filter

The inverter can become hot during normal operation. Therefore, the inverter uses built-in cooling fans to provide sufficient airflow to help in heat dissipation.

To ensure good ventilation and heat dissipation of the inverter, it is necessary to check the air inlet and outlet regularly.

Ensure that air inlets and outlets are not blocked and clean the vent with soft brush or vacuum cleaner if necessary.

7.3 Replace the Cooling Fans

If the internal temperature of the inverter is too high or abnormal noise is heard assuming the air vent is not blocked and is clean, it may be necessary to replace the external fans.



IMPORTANT!

Please disconnect the AC & DC power before replacing the fans.

Follow the steps below to replace the cooling fans:

1. Loosen the two screws on the fan tray. Tool: No.2 Phillips head screwdriver.

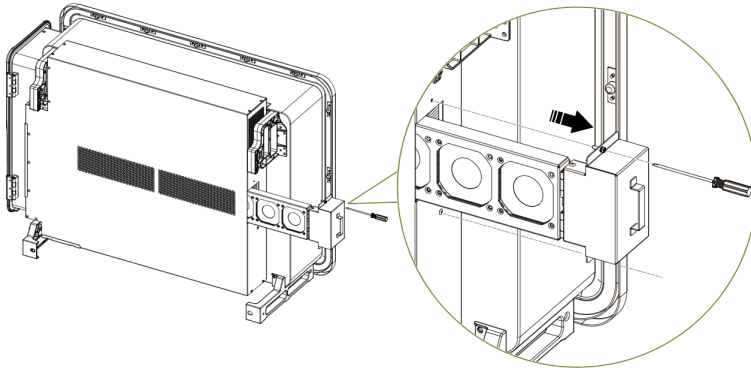

Figure 7-1 Remove the Fan Tray

- (R). Loosen the locking nut in the middle of the fan connector. Pull the two ends apart to disconnect the watertight connector.

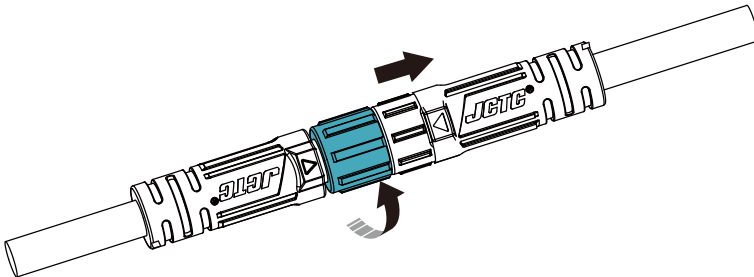

Figure 7-2 Disconnect the Watertight Cable Connector

2. Pull out the fan tray.

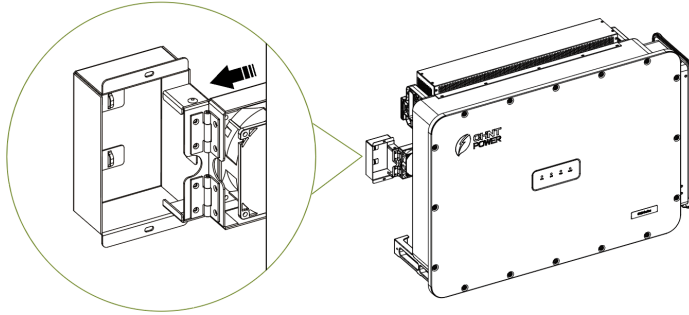

Figure 7-3 Pull Out Fan Tray

- (S). Loosen the screws securing each fan and remove the fans. Tool: No.2 Phillips screwdriver.

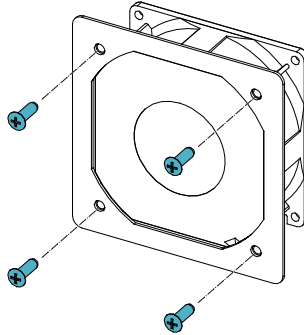

Figure 7-4 Replace Cooling Fans

- (T). Place the new cooling fans on the fan tray, and fasten the cable on the fan tray with cable ties. Tool: No.2 Phillips screwdriver, torque: 1.4 ~1.8 N·m.
3. Reinstall the assembled fans onto the inverter. Tool: No.2 Phillips screwdriver, torque: 1.6 N·m.

7.4 Replace the Inverter

**IMPORTANT!**

Make sure the AC breaker and DC switch of inverter are turned off.

Replace the inverter in reverse order relative to the installation steps in section 3.5 Installation Procedures.

1. Use a 17mm hexagon socket wrench to remove the M6x18 screws and M10 flat washers .
2. Remove the inverter from its mounting bracket with the coordination of 4 people.
3. Replace the new inverter on the mounting bracket and fasten it.

8 Troubleshooting

8.1 LED Indicator Troubleshooting

If the LED light indicates any faults, please perform troubleshooting according to the Table 8-1.

Table 8-1 Troubleshooting based on LED Lights

LED status	Solutions
COM LED light is off	<ol style="list-style-type: none"> 1. Observe for 5 minutes to see if the indicator light turns on again. 2. Connect to the inverter with the App to check for other faults. 3. Contact customer service personnel.
GRID LED light is blinking	<ol style="list-style-type: none"> 1. Disconnect the external AC circuit breaker. 2. Turn the DC switch to the “OFF” position. 3. Check the grid voltage and confirm the circuit breaker wiring is correct and secure.
The RUN LED light off or FAULT LED lights up.	Refer to Tables in Section 8.2 for troubleshooting.

8.2 Common Fault and Troubleshooting



DANGER!

Please disconnect the inverter from AC grid and PV modules before opening the equipment. Make sure hazardous high voltage and energy inside the equipment has been discharged.

Do not operate or maintain the inverter until at least 5 minutes after disconnecting all sources of DC and AC.

The inverter will be shut down automatically if the PV power generation system fails, such as output short circuit, grid overvoltage/under voltage, grid over frequency/under frequency, high environmental temperature or internal malfunction of the machine. The fault information will be displayed on the App interface.

The troubles can be identified and resolved based on the definitions, possible causes and recommended solutions listed in the following table. There are generally 3 types of faults: warning, protection and hardware fault. Proper analysis is recommended before contacting after-sales service.

Table 8-2 Troubleshooting List of Warning Faults

Fault Code	Definition Solutions
ExtFanErr	Definition: Cooling fan failure by visual check
	Possible causes: <ul style="list-style-type: none"> • Fan is blocked; • Fan service life has expired; • Fan socket connector has poor contact.
	Recommended solutions: <ol style="list-style-type: none"> 1. Observe for 5 minutes and see whether the alarm will be eliminated automatically; 2. Check for foreign objects on fan blades; 3. Switch off 3-phase work power supply and then reboot the system; 4. If the issue persists, contact after-sales service personnel.
IntFanErr	Definition: Internal fan error
	Recommended solutions: <ol style="list-style-type: none"> 1. Observe for 5 minutes and see whether the alarm will be eliminated automatically; 2. Check for foreign objects on fan blades; 3. Switch off 3-phase work power supply and then reboot the system; 4. If the issue persists, contact after-sales service personnel.
Warn0080	Definition: External heat exchanger fan alarm
	Recommended solutions: <ol style="list-style-type: none"> 1. Observe the inverter for 5 minutes to determine if the alarm clears automatically. 2. Inspect the heat exchanger fan for foreign objects obstructing the fan blades. 3. Turn off the DC switch, then re-energize the system. 4. If the issue persists, contact after-sales support.
Warn0030	Definition: EEPROM alarm
	Recommended solutions:

	<ol style="list-style-type: none"> 1. Observe for 5 minutes and see whether the alarm will be eliminated automatically; 2. If the issue persists, contact after-sales support.
Warn0040	Definition: DC SPD fault
	Recommended solutions: <ol style="list-style-type: none"> 1. Observe for 5 minutes and see whether the alarm will be eliminated automatically; 2. Check whether the DC/AC surge protectors are damaged. 3. If the issue persists, contact after-sales service personnel.
Warn0050	Definition: Temperature Sensor Error
	Recommended solutions: <ol style="list-style-type: none"> 1. Check the displayed temperature value. 2. Disconnect the AC power supply, then re-energize the system. 3. If the issue persists, contact after-sales service personnel.

Table 8-3 Troubleshooting List of Protection Faults

Fault Codes	Definition and Solutions
Protect0090	Definition: Bus over voltage
	Recommended solutions: <ol style="list-style-type: none"> 1. Restart the inverter: disconnect both AC and DC switches, wait for 5 minutes for all energy to discharge, then power it on again. 2. If the issue persists, contact after-sales service personnel.
Protect0070	Definition: High DC Bus Voltage Imbalance
	Recommended solutions: <ol style="list-style-type: none"> 1. Restart the inverter: disconnect both AC and DC switches, wait for 5 minutes for all energy to discharge, then power it on again. 2. If the issue persists, contact after-sales service personnel.
Grid Voltage Abnormal	Recommended solutions: <ol style="list-style-type: none"> 1. Check whether the inverter's AC input voltage is within the normal operating range. 2. Restart the inverter. 3. If the issue persists, contact after-sales service personnel.

Protect0020	<p>Definition: Grid relay error</p> <p>Recommended solutions:</p> <ol style="list-style-type: none"> 1. Restart the inverter: disconnect both AC and DC switches, wait for 5 minutes for all energy to discharge, then power it on again. 2. If the issue persists, contact after-sales service personnel.
TempOver	<p>Definition: Over-temperature protection error</p> <p>Recommended solutions:</p> <ol style="list-style-type: none"> 1. Confirm that external ambient temperature is within the specified range of operating temperature; 2. Check whether air inlet is blocked; 3. Check whether fan is blocked; 4. Check whether the location of installation is appropriate or not; 5. Observe for 30 minutes and see whether the alarm will be eliminated automatically; 6. If the issue persists, contact after-sales service personnel.
Protect0170	<p>Definition: DCI High</p> <p>Recommended solutions:</p> <ol style="list-style-type: none"> 1. Set the maximum DCI value to 5 A. 2. Restart the inverter and observe whether the fault clears automatically. 3. If the issue persists, contact after-sales service personnel.
IsolationErr	<p>Definition: Insulation resistance low</p> <p>Recommended solutions:</p> <ol style="list-style-type: none"> 1. Check the PV and grounding cables. 2. Restart the inverter and observe whether the fault clears automatically. 3. If the issue persists, contact after-sales service personnel.
GFCIEr	<p>Definition: Leakage current high</p> <p>Recommended solutions:</p> <ol style="list-style-type: none"> 1. Check wires of PV cable and grounding cable

	<ol style="list-style-type: none"> 2. Restart the inverter and observe whether the fault clears automatically. 3. If the issue persists, contact after-sales service personnel.
Protect0150	<p>Definition: Mini MCU Fault</p> <p>Recommended solutions:</p> <ol style="list-style-type: none"> 1. Restart the inverter: disconnect both AC and DC switches, wait for 5 minutes for all energy to discharge, then power it on again. 2. If the issue persists, contact after-sales service personnel
Protect0100	<p>Definition: The sensor fault of leakage current.</p> <p>Recommended solutions:</p> <ol style="list-style-type: none"> 1. Restart the inverter: disconnect both AC and DC switches, wait for 5 minutes for all energy to discharge, then power it on again. 2. If the issue persists, contact after-sales service personnel.
Reverse PVx electrode (x=1,2...30)	<p>Recommended solutions:</p> <ol style="list-style-type: none"> 1. Disconnect both the AC and DC switches. Use a meter to identify the PV string that has been connected in reverse polarity, then correct the PV string connection. 2. Restart the inverter and observe whether it returns to normal operation. 3. If the issue persists, contact after-sales service personnel.
High PVx Input Current (x=1,2...30)	<p>Recommended solutions:</p> <ol style="list-style-type: none"> 1. Inspect the PV input current to ensure it is within the acceptable range. 2. Restart the inverter: disconnect both AC and DC switches, wait for 5 minutes for all energy to discharge, then power it on again. 3. If the issue persists, contact after-sales service personnel.
High PVx Input voltage (x=1,2...30)	<p>Recommended solutions:</p> <ol style="list-style-type: none"> 1. Inspect the PV input voltage to ensure it does not exceed 1500V. 2. Restart the inverter: disconnect both AC and DC switches, wait for 5 minutes for all energy to discharge, then power it on again. 3. If the issue persists, contact after-sales service personnel.
Protect 0230	<p>Definition: Inverter open-loop self-test fault</p> <p>Recommended solutions:</p>

	<ol style="list-style-type: none">1. Restart the inverter: disconnect both AC and DC switches, wait for 5 minutes for all energy to discharge, then power it on again.2. If the issue persists, contact after-sales service personnel.
--	---

Table 8-4 Troubleshooting List of Hardware Faults

Fault Codes	Solutions
Fault 0010~0015	<ol style="list-style-type: none">1. Restart the inverter: disconnect both AC and DC switches, wait for 5 minutes for all energy to discharge, then power it on again.2. If the issue persists, contact after-sales service personnel.

9 Technical Data

Model Name	SCH250 / 275K-T2-EU	SCH333 / 350K-T2- EU
DC Input		
Max. DC Input Voltage	1500Vdc	
MPPT Operating Voltage Range	500 - 1500Vdc	
Start Voltage	550Vdc	
Rated DC Voltage	1190Vdc	
Number of MPPT	6	6
Number of DC Connection Sets per MPPT	5	5
Max. DC Input Current per MPPT	80 A	
Max. DC short-circuit current per MPPT	120 A	
String Fuse	/	
DC Disconnection Type	Integrated Switch	
AC Output		
Rated AC Power	250 / 275 kW	320 / 333 / 350 kW
Maximum AC power	250 / 275 kVA	352 / 333 / 350 kVA
Rated AC Voltage	800	
AC Voltage Range	680-880Vac	
Grid Connection Type	3 Φ / PE	
Maximum AC current	180.4 / 198.5 A	256.2 / 240.3 / 252.6 A
Grid Frequency	50Hz / 60Hz	
Grid Frequency Range	45-55Hz / 55-65Hz	
Power factor (cos ϕ)	> 0.99 (\pm 0.8 Adjustable)	
Current THD	< 1% (Rated Condition)	
AC Disconnect Type	/	
System parameters		
Topology	Transformerless	
Max. Efficiency	99.02%	
Euro Efficiency	98.8%	
Consumption at night	< 6W	
Protection		
DC Reverse Connection Protection	Yes	
AC Short-Circuit Protection	Yes	
Leakage Current Protection	Yes	
Grid Monitoring	Yes	
Ground Fault Monitoring	Yes	
Surge Protection	DC Type II / AC Type II	
Q at Night Function	Yes	
PID Prevent and Recovery	Yes	
Environmental parameters		
Ingress Protection	IP66	
Cooling Method	Cooling Fans	
Operating temperature	-30°C - +60°C	

Operating humidity	0-100%
Operating altitude	5000m (> 4000 m derating)
Display and communication	
Display	LED+APP (Bluetooth)
Communication	RS485
Mechanical Data	
Dimensions (WxHxD)	1120 * 780 * 390 mm
Weight (kg)	127 kg
DC Connection Type	MC4
AC Connection Type	OT/DT Terminal (Max. 400 mm ²)
Safety	
Certifications	IEC/EN 62109, IEC/EN 62920, IEC 61727/62116, IEC/EN 61000, IEC TS 62910, IEC 61683, EN 50530, NZS 4777.2, NRS 097-2-1, RPPS, EN 50549-2/10

Table 9-1 Datasheet

10 Quality Assurance

10.1 Liability Exemption

1. Exceed the quality assurance period of the product.
2. Cannot provide product serial number or the SN is not clear/complete. Incorrect or inappropriate use of the product (including installation and use).
3. Damage during transportation/storage/handling.
4. Misuse, abuse, intentional damage, negligence or accidental damage.
5. Improper commissioning, testing, operation, maintenance or installation performed by customer, including but not limited to:
 - Failure to meet safe operating environment or system requirements of external electrical parameters provided in written document;
 - Failure to operate the covered product in accordance with the product's operating manual or user guide;
 - Relocate and reinstall systems not in accordance with the requirements of Chint power;
 - Unsafe electrical or chemical environment or other similar kind of conditions;
 - Direct failure caused by wrong voltage or faulty power system;
 - Unauthorized disassembly of the products, or unauthorized modification of the product or provided software;
6. Entrust installation, maintenance personnel not designated by the CHINT to install, repair and disassemble the products.
7. Damages caused by ignoring the safety warnings in the manual or break the rules in relevant statutory safety regulations.
8. Damages caused by operating environment beyond the requirements of the product user manual or failure to commissioning, install, use and maintain the equipment according to the requirements of the product user manual.
9. Unforeseen disasters or irresistible accidents (including but not limited to acts of public enemies, acts of government agencies or domestic or foreign institutions, vandalism, riots, fires, floods, typhoons, explosions or other disasters, epidemic or quarantine restrictions, labor disturbances or labor shortages, accidents, cargo embargoes or any other events beyond the control of CHINT).
10. The lightning protection measures have not been implemented or are not in accordance with standards (Photovoltaic systems' lightning protection measures should comply with the relevant national and IEC standards; otherwise, it may result in damage to photovoltaic devices such as modules, inverters, distribution facilities, etc., due to lightning strikes).
11. Other circumstances that are not covered by the company's after-sales warranty agreement.

10.2 Quality Clause (warranty Clause)

1. For products that fail during the warranty period, our company will repair or replace new products free of charge;
2. Customer shall present the invoice of the product and date of purchase. At the same time, the trademark on the product should be clearly visible, otherwise we have rights to refuse quality assurance.
3. The unqualified product under replacement should be returned to our company;
4. It is necessary to provide a reasonable time for the company to overhaul the equipment.
5. For more warranty terms, refer to the applicable standard warranty policy in place at time of purchase.

If you have any questions about the photovoltaic Grid-tied inverter, please contact us, we will be very happy to help you.

11 Recycling

Distributors or installers should contact the inverter manufacturer after removing the inverter from the photovoltaic module and follow the instructions.



The inverter cannot be disposed of as household waste.

When the inverter's service life expires, please dispose of it in accordance with the electrical waste disposal laws applicable to the installation location.

You can contact the inverter manufacturer or distributor for handling.

Shanghai Chint Power Systems Co., Ltd.

Headquarters: No. 5999, Guangfulin Road, Songjiang District, 201616 Shanghai, P. R. China

Switchboard: +86-21-37791222-866000

Customer Service Hotline: +86-21-37791222-866300

Fax: +86-21-37791222-866001

Website: www.chintpower.com

Email: service.cps@chint.com