

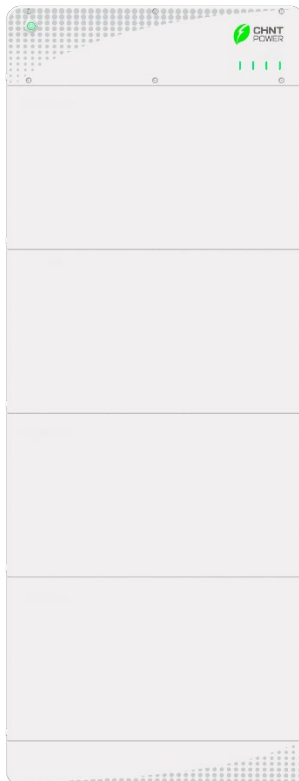

# User Manual for CPS ESSR-05/10/15/20KL1 Energy Storage Battery Unit



**Shanghai Chint Power Systems Co., Ltd.**

Version 2.0

July, 2025

Doc No.: 9.0020.0886B0

# Table of Contents

<b>0</b>	<b>Introduction</b>	<b>4</b>
<b>1</b>	<b>Safety Instructions</b>	<b>5</b>
1.1	Explanation of safety symbols in the manual	5
1.2	Interpretation of product markings	6
1.3	Precautions	7
<b>2</b>	<b>Product Introduction</b>	<b>9</b>
2.1	Introduction to residential energy storage battery unit	9
2.2	Model marking	9
2.3	Instruction of energy storage capacity	10
2.4	Dimension and appearance	12
2.5	LED display instruction	16
2.6	Product protection function	18
<b>3</b>	<b>Installation</b>	<b>19</b>
3.1	Inspection before installation	19
3.2	Installation tools	21
3.3	Installation torques	22
3.4	Installation requirements	22
3.4.1	Environment requirements	22
3.4.2	Installation method	23
3.4.3	Installation space	24
3.5	Installation methods	25
3.5.1	Floor installation	25
3.5.2	Wall-bracket Installation	28
<b>4</b>	<b>Electrical Connection</b>	<b>31</b>
4.1	Cable specification	31
4.2	Tools and torques	31
4.3	External wiring ports	31
4.4	Wiring instructions	32
4.4.1	Diagram of system structure	33
4.4.2	Grounding cable connection	33
4.4.3	Communication line and Power line connection	34
<b>5</b>	<b>Trial Operation</b>	<b>37</b>
5.1	Installation check	37
5.2	Inspection items of cable	37
5.3	Startup process	38
5.3.1	General startup process	38
5.3.2	Black start process	38

5.4	Shutdown process.....	38
<b>6</b>	<b>Storage and Recharging.....</b>	<b>39</b>
6.1	Battery storage requirements.....	39
6.2	Recharging cycle and requirements .....	40
6.3	Recharging operation.....	41
6.4	Battery power-on and commissioning steps .....	42
<b>7</b>	<b>Maintenance and Replacement.....</b>	<b>43</b>
7.1	Maintenance precautions .....	44
7.2	Maintenance items and cycle.....	45
7.3	Fault List.....	46
7.3.1	Troubleshooting of LED indicator .....	46
7.3.2	List of faults .....	46
<b>8</b>	<b>Technical Data .....</b>	<b>49</b>
<b>9</b>	<b>Quality Assurance.....</b>	<b>51</b>
9.1	Immunity from liabilities .....	51
9.2	Quality terms .....	52

## 0 Introduction



This manual contains important information about product installation and safe operation. Please read it carefully before use.

Thank you for choosing CPS ESSR L1 Series residential energy storage battery unit (hereinafter referred to as "battery unit" in this manual) produced by Chint Power Systems Co., Ltd. (hereinafter referred to as "Chint Power"). With innovative design and perfect quality control, the energy storage battery produced by Chint Power has high reliability.

This manual mainly introduces the product characteristics, performance indicators, appearance and interfaces, operating instructions, installation and maintenance of the CPS ESSR L1 Series CPS ESSR-05/10/15/20KL1 residential energy storage battery unit.

This manual is applicable to the following personnel:

- Professional technicians for installation, operation and maintenance of the product;
- Users of the product.

Please keep this manual properly for reference at any time. In case of any problems during installation or operation, please refer to this manual first, and the instructions in it can help you solve common problems. If the problem persists, you can contact the local dealer or representative.

Any reproduction, disclosure or copy in whole or in part is forbidden without prior written authorization. Chint Power reserves the right to modify and update this manual without prior written authorization. CHINT doesn't accept any responsibilities whatsoever for potential errors or possible lack of information in this document.

Users can get the latest manual from our sales channel or our official website: [www.chintpower.com](http://www.chintpower.com).

# 1 Safety Instructions

Read this manual carefully before installing and operating the energy storage battery. If the equipment is not properly installed and used in accordance with the contents of this manual, resulting in damage to the equipment, Chint Power has the right to refuse warranty claims.

Please read this manual carefully before installation. If any damage to the equipment occurs as a result of installation and operation not in accordance with the instructions in this manual, we reserve the right to deny warranty!

## 1.1 Explanation of safety symbols in the manual



### **DANGER!**

A high-level potential hazard that, if not avoided, will result in death or serious injury.



### **WARNING!**

A moderate-level potential hazard that, if not avoided, may result in death or serious injury.



### **CAUTION!**

A low-level potential hazard that, if not avoided, may result in moderate or mild injury.



### **NOTICE!**

A potential risk that, if not avoided, may result in the equipment not functioning properly or causing property damage.



### **Instruction!**

Additional information in the manual that highlights and supplements the content and may also provide tips or tricks to optimize the use of the product, which helps solve problems or save time.

---

## 1.2 Interpretation of product markings

---



### **DANGER! Electric Shock!**

There is a high voltage inside the machine body, so the instructions in the User Manual must be followed for operation of this product.

---



### **Keep away from fire source!**

There is a lithium-ion battery in the equipment, which need to be stored or used away from fire sources.

---



### **DANGER! Explosion!**

The battery itself is at risk of explosion and therefore shall be used as required.

---



### **Read the Manual!**

Refer to the user manual for further details.

---



### **WARNING!**

Serious injury or equipment damage may result if the equipment is not operated in accordance with the warnings.

---



### **Protective Earth!**

This marking is located at the protective earth (PE) terminal and shall be firmly earthed to ensure operator safety.

---



### **Waste Sorting!**

The battery box shall not be disposed of with domestic waste at the end of its service life.

---



### **Recycling**

The battery box shall be disposed of in an appropriate environmentally-safe recycling facility.

---



### **Certification Marking**

The product complies with the provisions of the CE Directive.

---



### **Safety Gear**

Wear safety gears when handling the battery box.

---

## 1.3 Precautions

---

### **WARNING!**



When installing, operating and maintaining the equipment, read this manual first and follow all safety precautions marked on the equipment and in the manual.

---

### **DANGER!**



- There is voltage in the equipment, and non-standard operation may cause electric shock or fire, resulting in death, serious injury or serious property loss.
  - It is strictly prohibited to install, use and operate outdoor equipment and cables in severe weather such as thunder and lightning, rain, snow and strong wind of force 6.
  - It is prohibited to not carry out installation, wiring, maintenance, replacement and other operations with electricity.
  - It is prohibited to clean the equipment with water.
  - Before touching any conductor surface or terminal, the voltage at the contact point shall be measured to confirm that there is no risk of electric shock.
  - Paint scratches during equipment transportation and installation shall be repaired in time. It is strictly prohibited to expose the scratched parts to the outdoor environment for a long time.
  - The battery terminal components shall not be affected during handling. Lifting and handling via the battery terminal bolts are not allowed.
  - Under no circumstances shall the structure and installation sequence of the equipment be changed without the permission of the manufacturer.
  - In case of fire, evacuate the building or equipment area and press the fire alarm bell, or call the fire alarm number. Under no circumstances shall re-entry into a burning building be permitted.
-

**NOTICE!**

- During transportation, transfer, installation, wiring and maintenance, the requirements of laws, regulations and relevant standards of the country and region where the equipment is located must be met.
- The materials prepared by the user and the tools required during the operation must meet the requirements of laws, regulations and relevant standards of the country and region where they are located.
- The grid connection can only be carried out after obtaining the permission of the power department of the country and region where it is located.
- The composition and working principle of the entire PV grid-connected power generation system and the relevant standards of the country/region where the project is located shall be fully familiarized.

---

**CAUTION!**

Check the wall bracket again before hanging the machine to ensure that the wall bracket is firmly fixed on the supporting surface.

---

## 2 Product Introduction

### 2.1 Introduction to residential energy storage battery unit

CPS ESSR L1 series energy storage battery unit is suitable for residential energy storage. The energy storage battery includes a power control module and a battery extension module, which can store and discharge electric energy according to the requirements of inverter management system. The input and output ports of the CPS ESSR L1 series energy storage battery unit are with DC power.

**Battery charging:** The power control module is connected with the energy storage terminals (BAT+, BAT-) of the inverter to charge the battery under the control of the inverter and store the excess energy generated by the PV system in the battery.

**Battery discharging:** When the PV energy is insufficient to supply power to the load, the energy storage battery unit shall control the battery to supply power to the load, and output the energy stored in the energy storage battery unit to the load through the inverter.

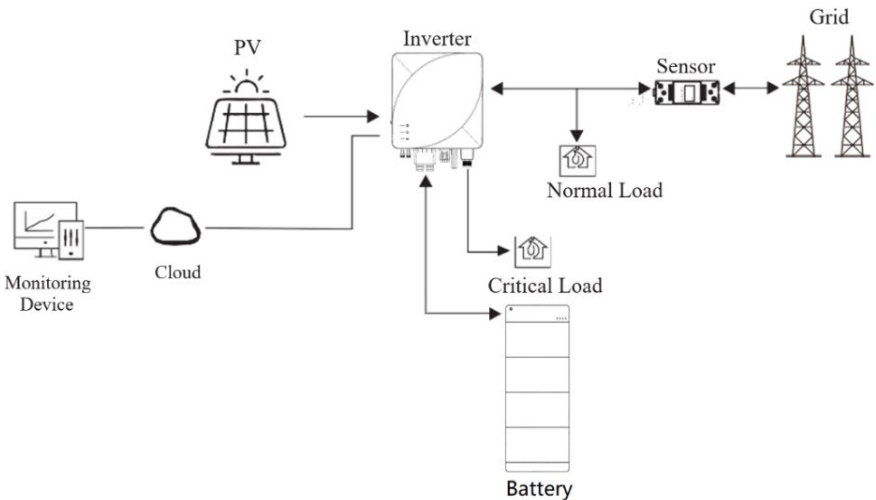

Fig 2-1: Typical Application of Energy Storage Battery Unit

### 2.2 Model marking

The model of CPS ESSR L1 series energy storage battery unit is CPS ESSR-05 (10/15/20) KL1. The following is an example of the meaning of CPS ESSR-05KL1.

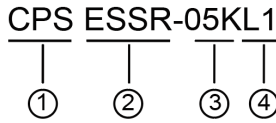

Figure 2-1: Model of Energy Storage Battery Unit

No.	Name	Meaning
1	Company name	CPS: Chint Power Systems
2	Product type	Residential energy storage system
3	Energy level	05K: energy level of 5.12kWh
4	Design code	L1: product number of low voltages (LV) series

Table 2-1 Instruction of Model Meaning

### 2.3 Instruction of energy storage capacity

The energy storage battery unit supports capacity extension. Up to 3 battery stacks can be connected in parallel, each of which can support up to 4 battery extension modules.

For the Australian market, an overcurrent protection and isolation device that isolates both positive and negative conductor simultaneously is required between the inverter and battery system and between parallel battery systems.

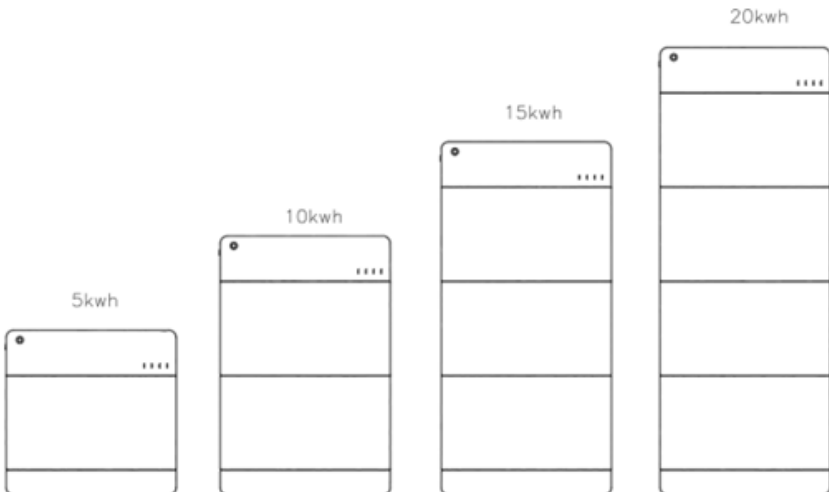

Figure 2-2 Instruction of Energy Storage Capacity

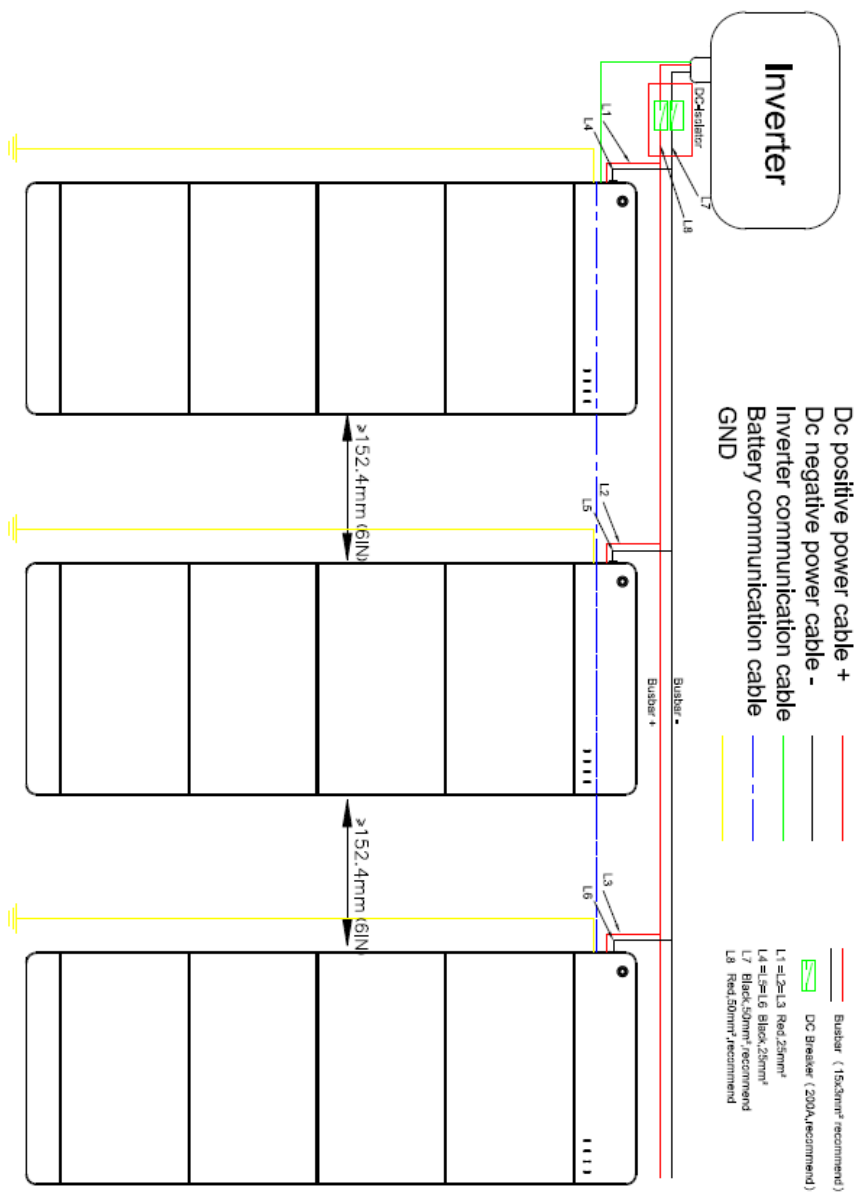

Figure 2-3 Energy Storage extension Instruction

## 2.4 Dimension and appearance

### 1. Introduction to overall appearance of energy storage battery unit

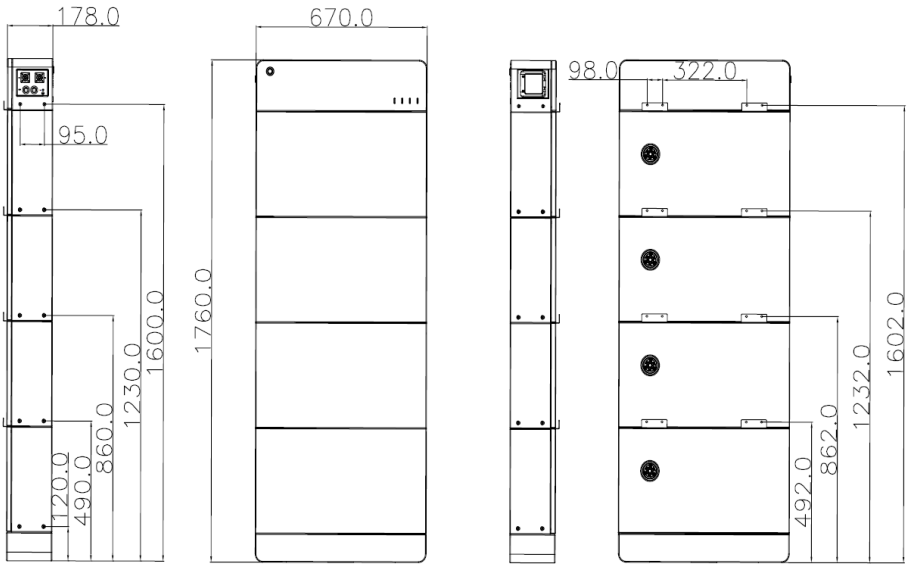

Figure 2-4 Dimensions of Energy Storage Battery Unit (unit:mm)

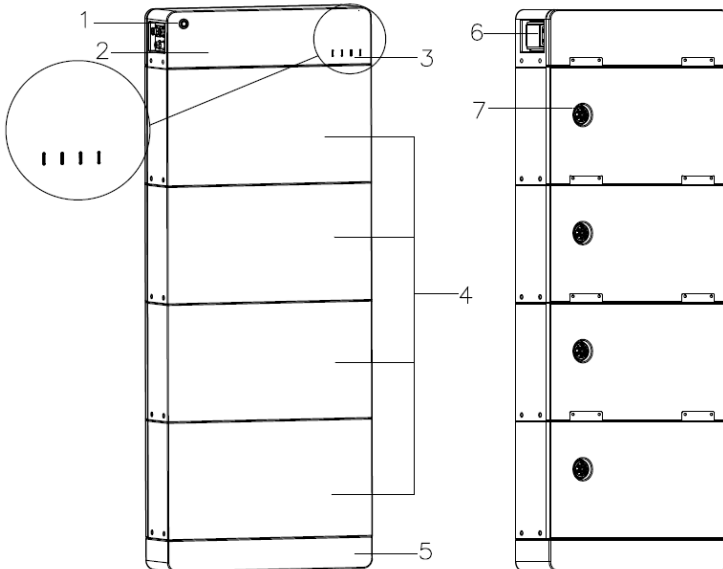

Figure 2-5 Product Appearance

No.	Name	Function
1	On/Off button	Indicating startup/shutdown and operation state
2	Power control module	Controlling battery operation and inverter communication
3	LED indicator	Indicating SOC of the battery of the product
4	Battery extension module	Battery extension unit
5	Base	Carrying battery extension module
6	Circuit breaker	Manual break switch
7	Explosion-proof valve	Releasing battery pack pressure

Table 2-2 Main Components of the Product

## 2. Power control module

The power control module is responsible for battery module management and communication, with a rated current of 120A and power of 6 kW.

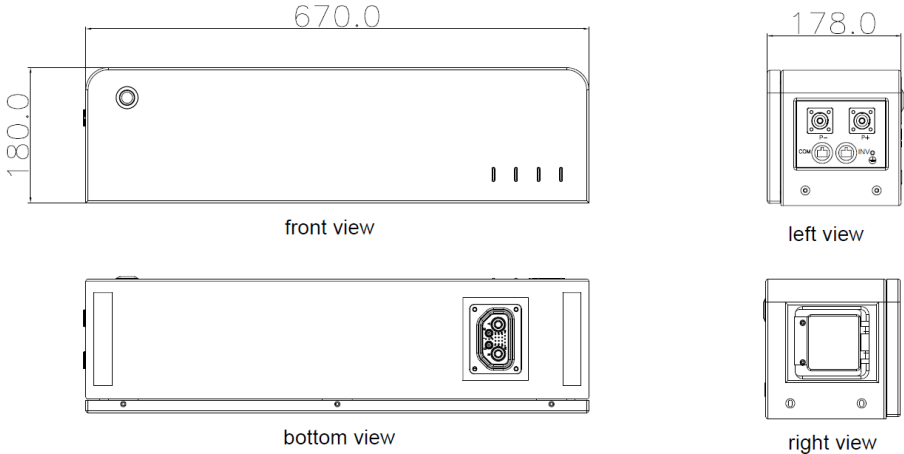

Figure 2-6 Dimensions of Power control module (unit:mm)

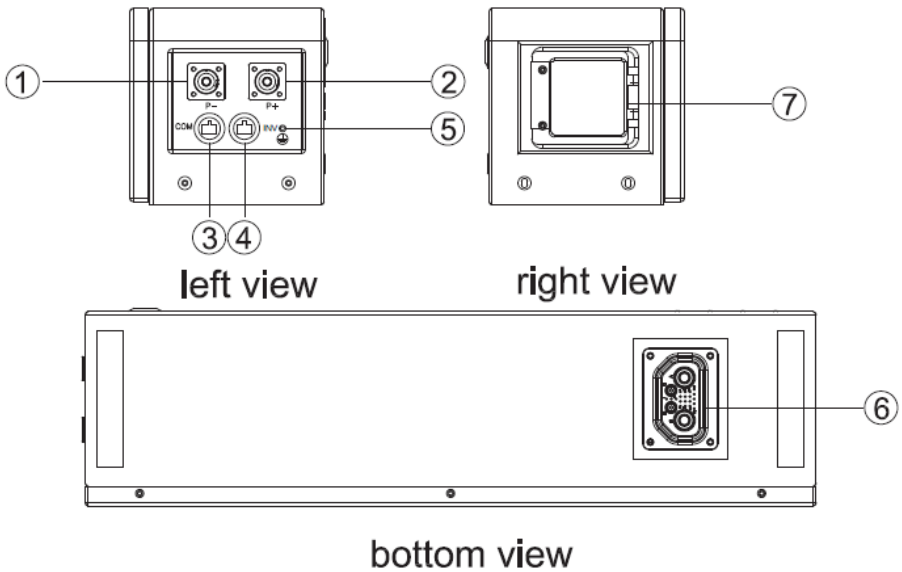

Figure 2-7 Appearance of Power control module

No.	Name	Function
1	Negative terminal of battery output	Negative terminal of battery output
2	Positive terminal of battery output	Positive terminal of battery output
3	Extension communication port	Extension communication OUT
4	Inverter communication port	Inverter communication/extension communication IN
5	Grounding terminal	Grounding lead-out terminal
6	Power plug-in female terminal	Power and communication terminal
7	Circuit breaker	To cut off the circuit

Table 2-3 Main Components of Power control module

### 3. Battery extension module

The standard rated capacity of the battery extension module is 5.12kWh, and it supports the stack installation of up to 4 modules.

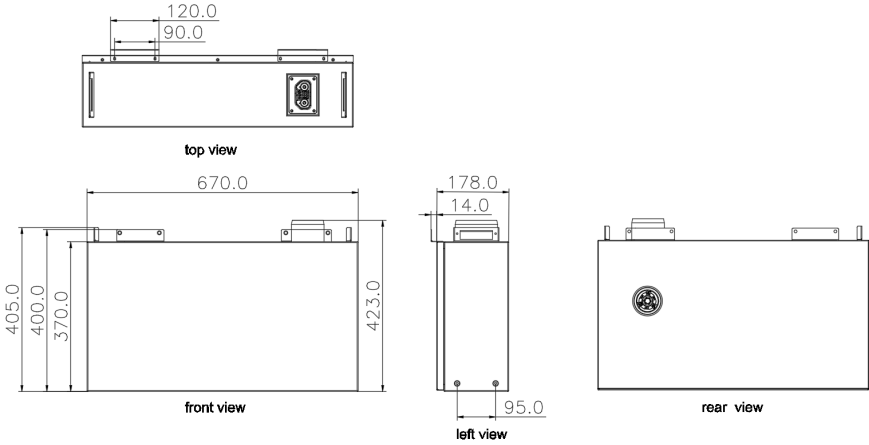

Figure 2-8 Dimensions of battery extension module

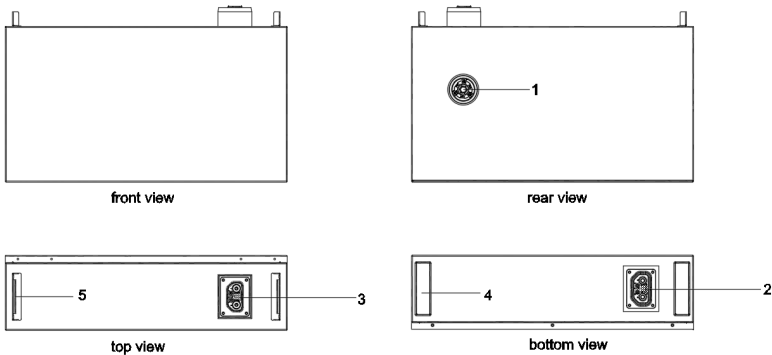

Figure 2-9 Appearance of battery extension module

No.	Name	Function
1	Explosion-proof valve	Pressure relief to prevent explosion
2	Power plug-in female terminal	Power and communication terminal
3	Power plug-in male terminal	Power and communication terminal
4	Positioning area	Positioning and fixing hole
5	Handle	Handle and positioning

Table 2-4 Main Components of battery extension module

4. Base module

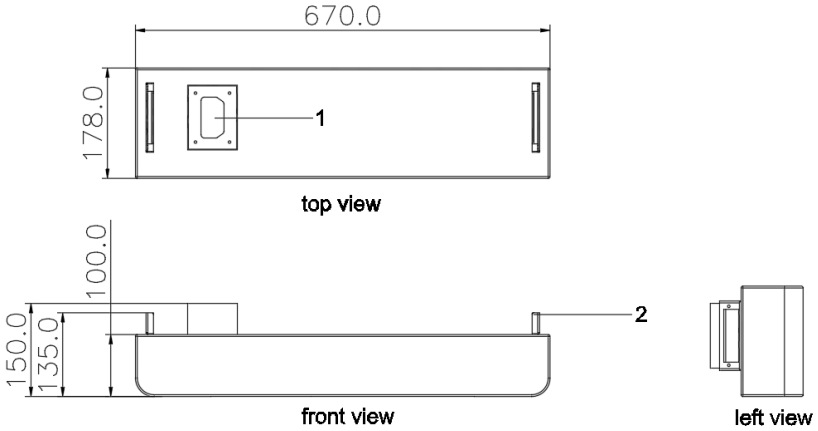

Figure 2-11 Appearance and Composition of Base Module

No.	Name	Function
1	Power plug-in male terminal	Power and communication terminal
2	Handle	Handle and positioning

Table 2-5 Main Components of Base Module

## 2.5 LED display instruction

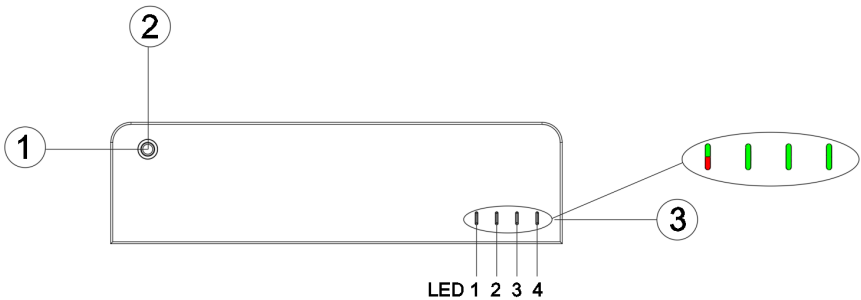

Figure 2-12 Power-on Button and Indicator

No.	Description	Indicator Meaning
1	ON/OFF button	<ul style="list-style-type: none"> <li>Power on/off the battery unit</li> </ul>
2	System operation state indicator	<ul style="list-style-type: none"> <li>In the standby state, the operation state indicator flashes 1 time (on for 0.25s and off for 3.75s);</li> <li>In the charging process (charging current is greater than 1A), the operation state indicator stays on;</li> <li>In the discharging process (discharge current is greater than 1.6A), the operation state indicator shows a 3-flash pattern (on for 0.5s and off for 1.5s).</li> </ul>
3	Alarm indicator	<ul style="list-style-type: none"> <li>After the alarm is started, the alarm indicator flashes (on for 0.5s and off for 0.5s)</li> <li>After the protection is started (except for undervoltage protection and overvoltage protection), the alarm indicator stays on;</li> <li>When there is no alarm and no protection, the alarm indicator goes out.</li> </ul>
	SOC indicators	<ul style="list-style-type: none"> <li>In the standby state, SOC (State of charging) indicators display normally;</li> <li>During charging, SOC indicators LED1, LED2, LED3 and LED4 flash accordingly when SOC is 0~25%, 25~50%, 50~75% and ≥75%;</li> <li>During the discharging process, SOC indicators LED4, LED3, LED2 and LED1 go out accordingly when SOC is &lt;75%, &lt;50%, &lt;25%, as well as undervoltage protection is reached.</li> </ul>

Table 2-6 Panel Buttons and Indicators

## 2.6 Product protection function

- Short circuit protection
- Overcharge protection
- Over-discharge protection
- Over current protection
- Temperature protection
- Balance between cells
- Power module temperature monitoring
- Ambient temperature monitoring
- Cell temperature monitoring

### 3 Installation

#### 3.1 Inspection before installation

Before installation, check whether the following items are contained in the packing box of each battery extension module and whether there is any damage. The delivery list of each battery extension module is as follows:

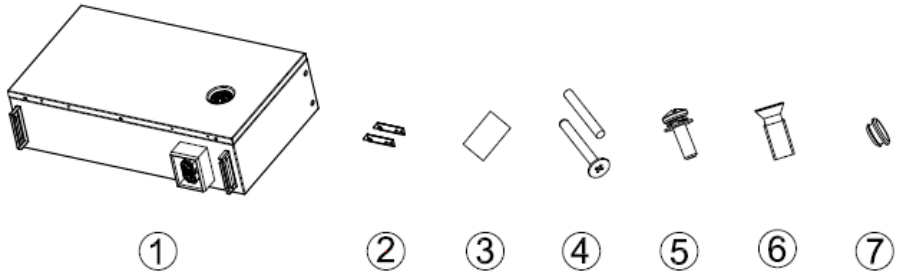

Figure 3-1 delivery list of each battery extension module

No.	Accessory Name	Qty.	Purpose
1	Battery extension module	1	One extension module is 5kwh
2	Wall anchor	2	Fasten battery module onto wall
3	Document bag	1	Include packing list
4	Φ8x40 tapping screw	4	Lock wall anchor onto wall
5	M4x14 combination screw	4	Lock battery extension modules
6	M4x10 countersunk head screw	4	Install wall anchor on battery module
7	Dust plug	4	Dust prevention

Table 3-1 Accessories in packing box of each battery extension module

Before installation, check whether the following items are contained in the packing box of the power control module and whether there is any damage. The delivery list of the power control module is as follows:

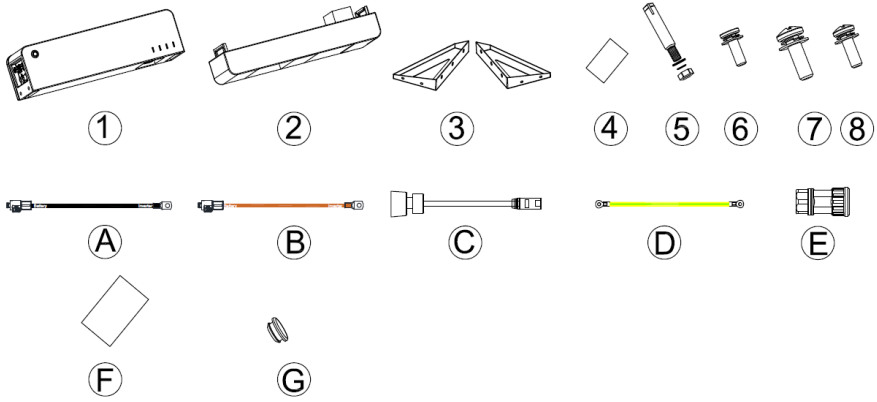

Figure 3-2 delivery list of power control module

No.	Accessory Name	Qty.	Purpose
1	Power control module	1	Control battery operation and inverter communication
2	Base	1	Install battery extension module
3	Wall bracket	1	Support the whole battery unit
4	Document bag	1	Include packing list & quick guide
5	M12x100 expansion screw	6	Fasten wall bracket
6	M6x14 combination screw	4	Fasten wall bracket and base
7	M4x14 combination screw	4	Fasten power control module
8	M4x10 combination screw	1	Fasten GND cable
A	Negative power output line (2m)	1	Connect inverter to battery P-
B	Positive power output line (2m)	1	Connect inverter to battery P+
C	Inverter communication cable (2m)	1	Communicate with inverter
D	Grounding cable (2m)	1	GND
E	RJ45 Socket	1	Protect COM interface from water ingress
F	Positioning template	1	Position mounting holes
G	Dust plug	4	Dust prevention

Table 3-2 Accessories in packing box of power control module

### 3.2 Installation tools











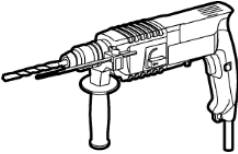
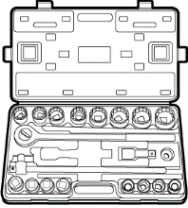

Type	Tools and Instruments		
Installation	 Impact drill (Drill bit $\Phi 8$ , $\Phi 16$ m)	 Torque socket wrench	 Multimeter
	 Marker	 Steel tape	 Level ruler
	   Torque screwdriver	 Diagonal pliers	 Rubber hammer
	 Wire Crimpers (Type: PV- CZM- 22100/19100 )	 Wire stripper	
Personal protection	 Safety gloves	 Protective glasses	 Safety shoes

Table 3-3 Preparation of Installation Tools

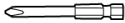
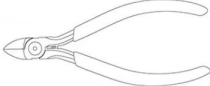
### 3.3 Installation torques

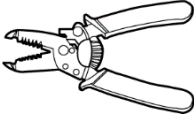
No.	Name	Purpose	Torque value
1	M4 torque screwdriver	Tighten M4x14 combination screw and M4x10 countersunk head screw	1.2 N.m
2	M6 Torque screwdriver	Tighten $\Phi$ 8x40 tapping screw and M6x14 combination screw	5 N.m
3	#19 socket wrench	Tighten M12x100 expansion screw	40-45N.m

Table 3-4 Installation Torques

### 3.4 Installation requirements

#### 3.4.1 Environment requirements

The service life of the inverter can be prolonged by avoiding the battery unit from direct sunlight, direct rain and snow accumulation.

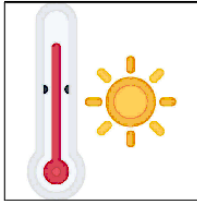
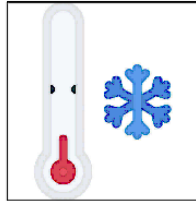
**Max +50 C°**

**Min -10 C°**

**RH+5%~+95%**

Figure 3-3 Schematic Diagram of Installation Environment

### 3.4.2 Installation method

Before installing the battery unit, confirm whether the installed supporting structure can bear the weight of the battery unit, check whether the ground is level, and install the energy storage battery unit according to the following instructions:

- a) Vertical installation only;
- b) No forward tilting installation;
- c) No inverted installation;
- d) No horizontal installation;

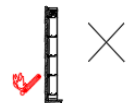
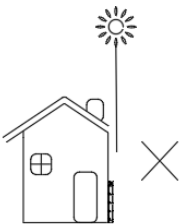
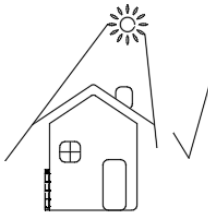
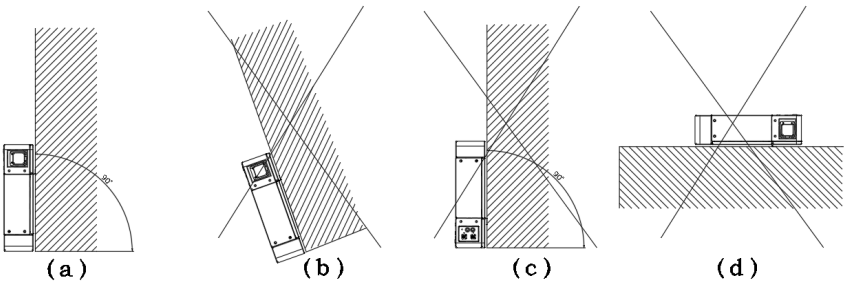

Figure 3-4 Floor Installation

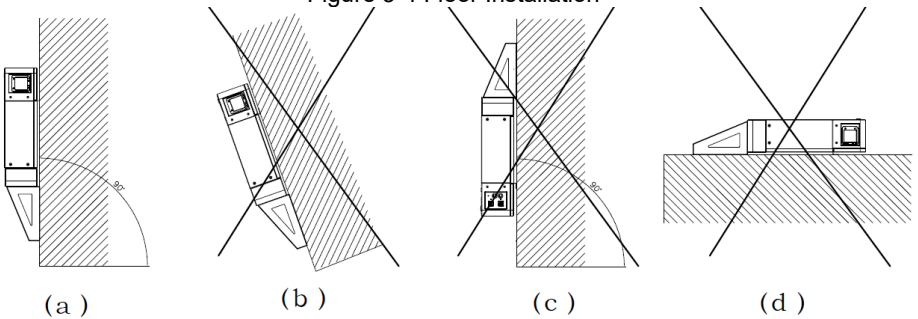

Figure 3-5 Wall-bracket Installation

### 3.4.3 Installation space

The distance between the energy storage battery unit and the surrounding objects shall meet the following conditions:

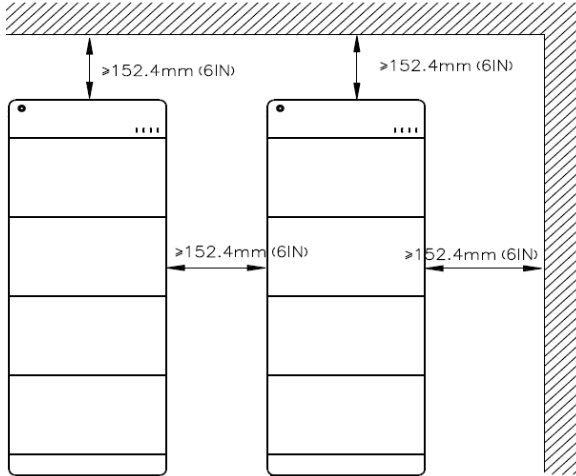

Figure 3-6 Dimensional Requirements for Floor Installation

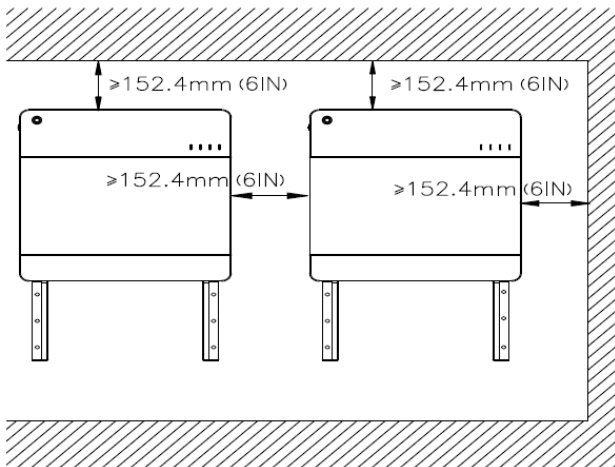

Figure 3-7 Dimensional Requirements for Wall-bracket Installation

**NOTICE!**



The distance between two parallel energy storage battery units must be  $\geq 152.4\text{MM}(6\text{IN})$ , and good ventilation shall be ensured. If the surroundings are relatively closed, increase the spacing appropriately.

### 3.5 Installation methods

#### 3.5.1 Floor installation

- Place base on a level floor and keep within 15 mm from wall surface. Align reference line of positioning template with top line of base and then position the template onto the wall. Drill correct number of holes according to hole positions on the template, and knock plastic pipes of  $\Phi 8 \times 40$  tapping screws into the wall.

Tools: electric drill (with  $\Phi 8$ mm drill bit), and rubber mallet.

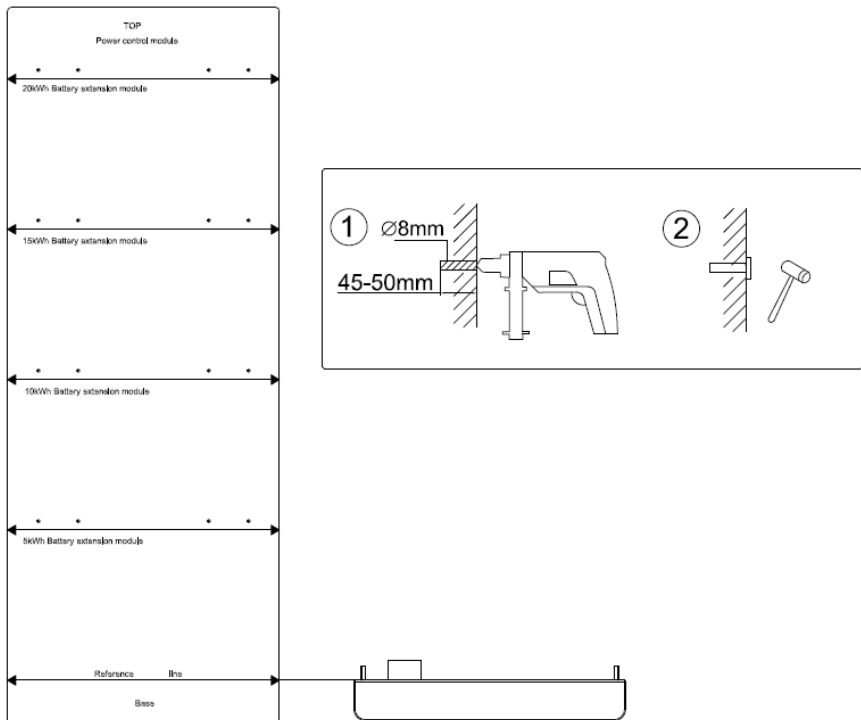

Figure 3-8 Drill correct number of holes

- Two people jointly lift the battery extension module, align the battery extension module interface with the base and place it on the base.

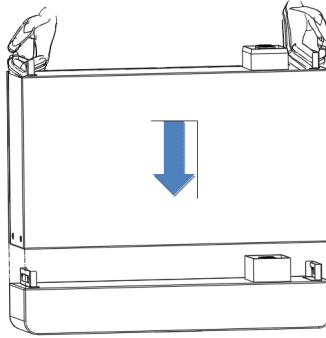

Figure 3-9 Position battery extension module on of base

- Lock screws into screw holes on both sides of the battery extension module, to ensure extension module is securely installed on the base; fasten wall anchor on the battery extension module, and then fasten it on the wall. Similarly, install other battery extension modules in turn and fasten them.  
Tools: M4x14 combination screw, M4x10 countersunk head screw,  $\Phi 8 \times 40$  tapping screws, M4 torque screwdriver, M6 torque screwdriver

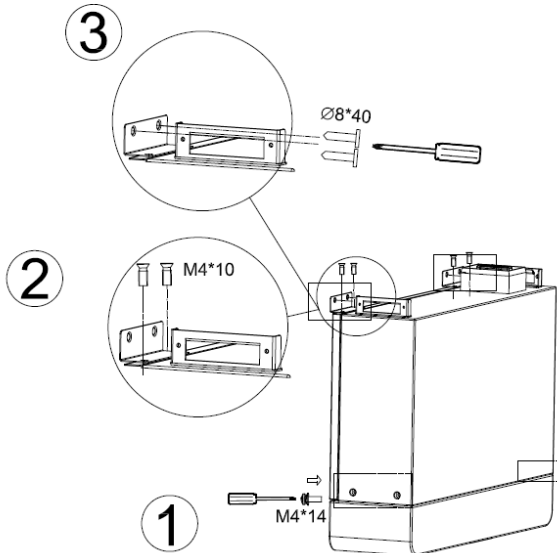

Figure 3-10 install battery extension Module

4. Fasten power control module onto the battery extension module.

Tools: M4x14 combination screw and M4 torque screwdriver

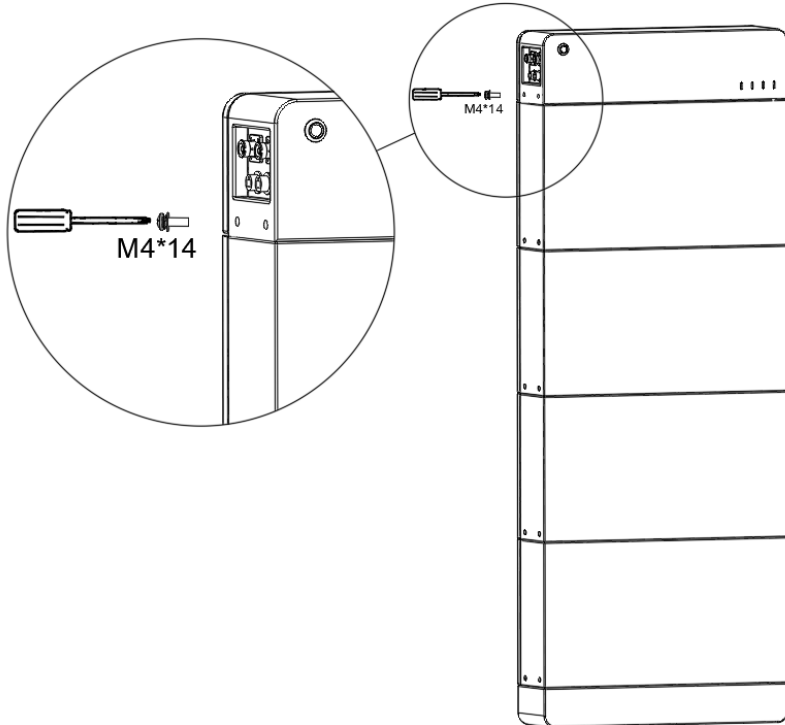

Figure 3-11 Installation of Power control module

---

**NOTICE!**



- When installing a battery extension module, screws must be installed on its left and right sides at first, the wall anchors must be locked on the wall with tapping screws, and then the next battery extension module can be installed.
  - In order to prevent damage caused by equipment toppling, the installation floor must be level and free of foreign objects.
-

5. Insert dust plugs into all the screw holes as showed, repeat this operation on the oppsite side till all the scew holes are plugged up.

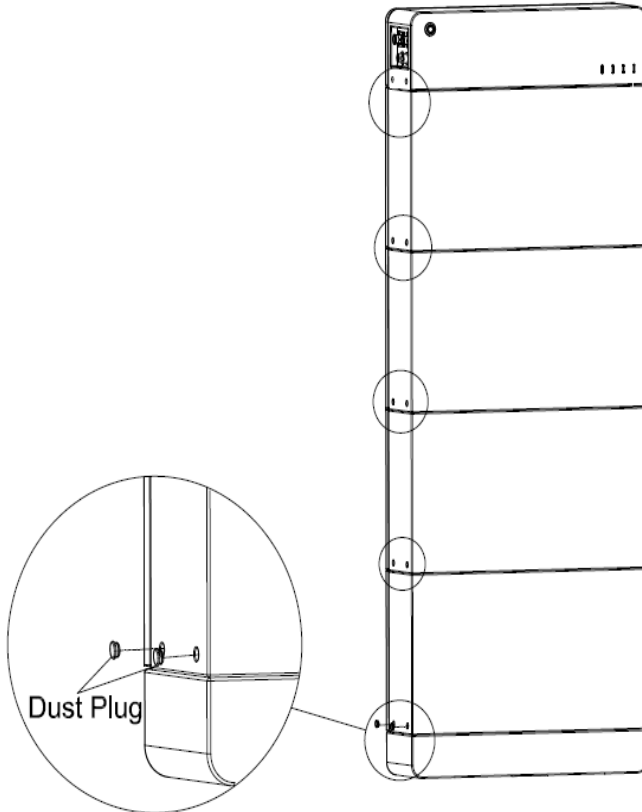

Figure 3-12 Insert dust plugs

### 3.5.2 Wall-bracket Installation

1. Make sure the installation position is level with a level ruler at first, and then mark the hole positions on the structure wall according to the dimensions of the wall bracket. Drill holes at the marked positions, knock external steel pipe of M12x100 expansion screws into wall, and then fix the wall bracket on the wall with M12x100 expansion screws.  
Tools: marker, electric drill (with  $\Phi 16\text{mm}$  drill bit), rubber mallet and #19 socket wrench.

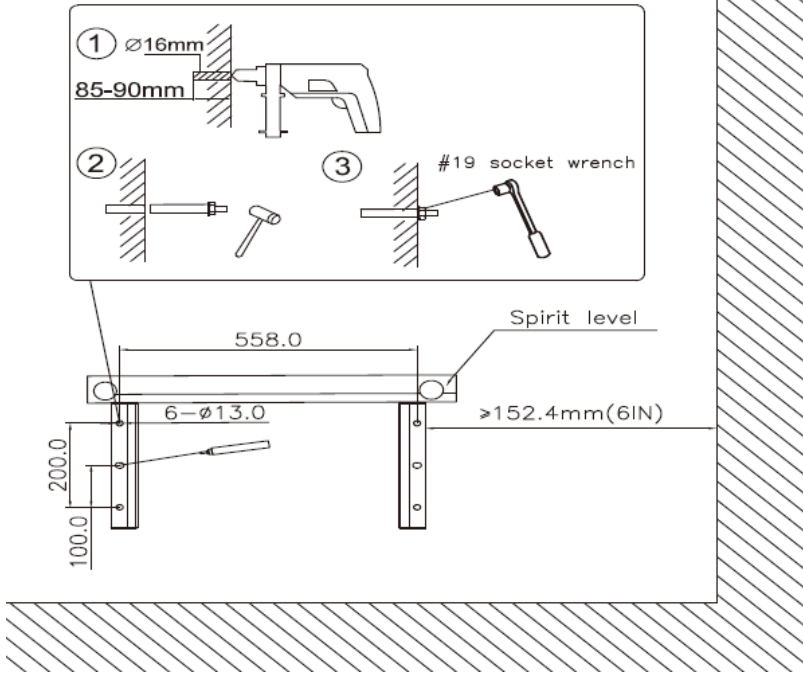

Figure 3-13 Mounting Hole Positions of Wall Bracket

2. Secure the base to the wall bracket.  
Tools: M6x14 cross outer hexagon triple combination screw and M6 torque screwdriver.

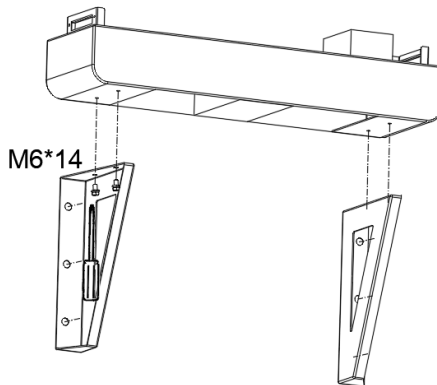
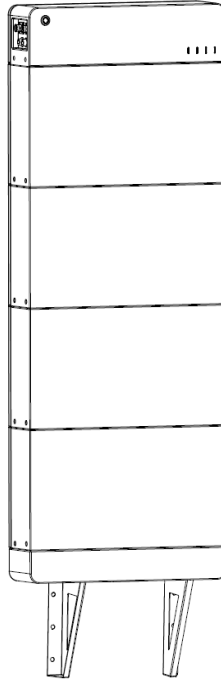

Figure 3-13 Fixing of Base to Wall Bracket

3. Finish all the subsequent steps by referring to the procedures of floor installation.



4.

Figure 3-14 Installation of Power control module

---

**CAUTION!**



- The battery extension module weighs about 46 kg (≈100 lbs). Check the wall bracket again before hanging the battery unit to ensure that the wall bracket is firmly fixed on the support structure and locked with the base. Considering the weight of the machine, it is recommended that at least 2 people install it together (it is not recommended that the battery unit with 3 or more battery extension modules is installed with wall-bracket).
- When installing a battery extension module, screws must be installed on its left and right sides at first, the wall anchors must be locked on the wall with tapping screws, and then the next battery extension module can be installed.

## 4 Electrical Connection

### CAUTION!



Cable connections must comply with national electrical standards and all other applicable codes or legal standards.

### 4.1 Cable specification

Name	Type	O. D. (mm)	Cross-sectional Area (mm <sup>2</sup> )
DC cable	Silicon wire, 600V, 4 AWG	8~10	25
GND cable	10 AWG, yellow-green wire	/	5.26
COM cable	CAT5e shielded twisted pair	/	0.5

Table 4-1 Cable Specifications

### 4.2 Tools and torques

No.	Tool	Purpose	Torque
1	M4 screwdriver	Locking grounding cable	20~30kgf.cm
2	Diagonal pliers	Cutting cables	-
3	Wire stripper	Stripping cables	-
4	Crimping pliers	Crimping terminals	-

Table 4-2 Tools and Torques Required

### 4.3 External wiring ports

The external wiring ports of the energy storage battery unit is shown in the following figure:

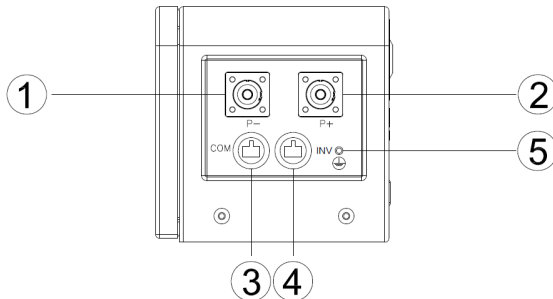

Figure 4-1 External Wiring Ports

No.	Name	Function
1	DC output negative quick-plug terminal	Connect negative power cable
2	DC output positive quick-plug terminal	Connect positive power cable
3	Multi-cluster extension communication port	Communicate between battery extension modules
4	Communication interface	Communicate with inverter
5	Grounding terminal	Connect to external Grounding point

Table 4-3 External Wiring Ports of Energy Storage Battery Unit

## 4.4 Wiring instructions



### NOTICE!

Read the technical data in Chapter 8 carefully before wiring.



### DANGER!

Before making an electrical connection, ensure that the "circuit breaker" of the energy storage battery unit and all switches connected to the energy storage are in the "OFF" state.



### Warning:

- Equipment damage caused by incorrect wiring is not covered by the equipment warranty.
- The relevant operations of electrical connection must be carried out by professional electricians.
- Operators must wear protective gears when making electrical connections.

### 4.4.1 Diagram of system structure

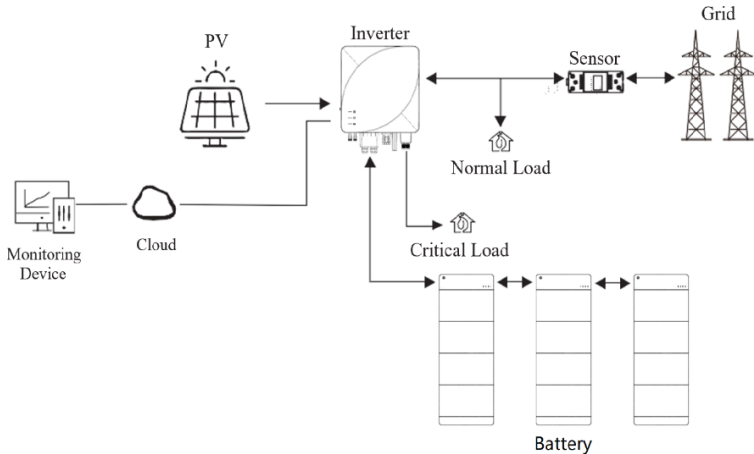

Figure 4-2 Parallel Structure of Multiple Energy Storage Battery Units



#### IMPORTANT!

The length of DC input line and signal line between energy storage unit and inverter shall be  $\leq 10\text{m}$ .

### 4.4.2 Grounding cable connection



#### DANGER!

Confirm that the protective grounding cable is reliably connected. Disconnection or looseness may cause electric shock.

Connect the grounding cable according to the following steps and the figure:

1. Connect the grounding point of the power control module to external grounding point with grounding cable..
2. After connecting the grounding cable, tighten the compression nut of the cable fastening head.

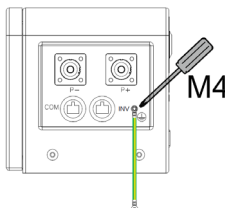

Figure 4-3 grounding



**IMPORTANT!**

After installing the grounding cable, apply silicone adhesive or paint on the outside of the grounding terminal for protection.

**4.4.3 Communication line and Power line connection**

**NOTICE!**



When arranging the signal cable, make sure to separate the routing of the signal cable from that of the power cable, and avoid large interference sources during routing, so as not to affect the communication due to signal interference.

There are two communication ports on the battery side, namely COM port and INV port. The INV port is used for communication with the inverter. The COM port is used for communication between battery extension modules when multiple energy storage battery units are connected in parallel, in which the COM port of one battery unit is connected with the INV port of its next cascade battery unit;

For the Australian market, an overcurrent protection and isolation device that isolates both positive and negative conductor simultaneously is required between the inverter and battery system and between parallel battery systems.

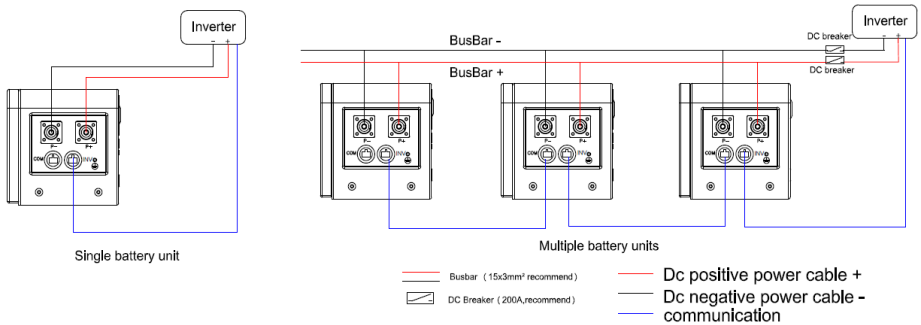

Figure 4-4 Communication and power line connection diagram

Note: There is an integrated DC circuit breaker in each battery control module which operates both the positive and negative conductor.

1. If inverter connects to a single battery unit or the first one of multiple networking battery units, connect COM cable to COM port of inverter and INV port of battery unit according to cable stickers as shown in fig.1-a; for the remaining networking battery units, connect COM cable to COM and INV port of battery units, matching RJ45 socket when connecting RJ45 plug into COM port as shown in fig.1-b.

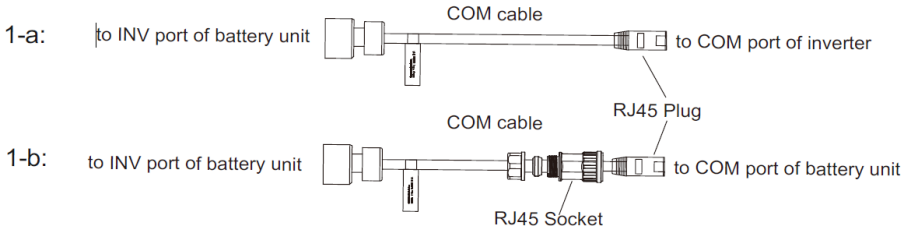

Figure 4-5 communication cable connection

2. Identify carefully cable stickers on Positive and Negative power output lines. Tighten OT terminals onto DC busbars of inverter.



Figure 4-6 crimp OT terminal

3. Insert the other ends of the power output line of the energy storage battery unit into the DC output positive quick-plug terminal (P+) and the DC output negative quick-plug terminal (P-) corresponding to the power control module.

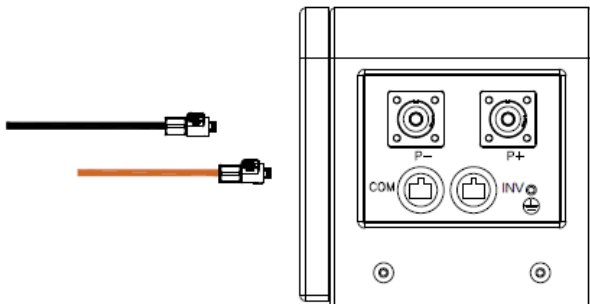

Figure 4-7 Insert power output line to power control module

4. To disconnect the power output line, press and hold the button on the cable connector and slide it outward, and pull out the connector with a slight force.

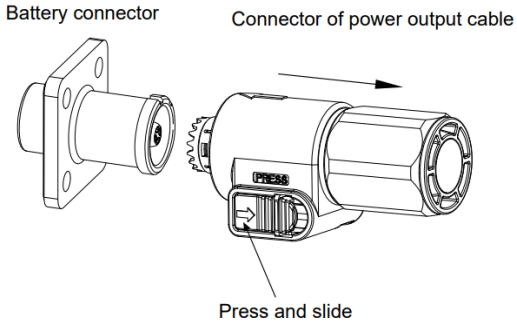

Figure 4-7 Unplugging Cable Connector

## 5 Trial Operation

---

### **WARNING!**



Before trial operation, please follow the following guidelines to eliminate hidden dangers and ensure safety.

---

### 5.1 Installation check

Perform the following checks with reference to Section 3.5 Installation methods:

- Confirm that the support structure is firm and reliable.
- Confirm that all mounting screws have been tightened according to the specified torque.

### 5.2 Inspection items of cable

Perform the following inspections with reference to Section 4 Electrical Connection connection:

- Confirm that all cables are connected firmly and reliably, and there is no wrong connection or missing connection.
- Confirm that all cables are placed properly and will not be damaged mechanically.
- Confirm whether the positive and negative polarities of the DC cable on the input side are correct.
- Confirm that the circuit breaker and all switches connected to the energy storage are in the "OFF" state.
- Confirm that the ground wire is connected correctly, firmly and reliably.
- Confirm that the installation space is reasonable, the environment is clean and tidy, and there is no construction residue.

## 5.3 Startup process

Before trial operation, the above inspection must be completed to confirm that there is no error, and then the inverter shall be put into trial operation according to the following steps.

### 5.3.1 General startup process

1. Close DC Breaker (if any) configured between inverter and battery unit.
2. Close the circuit breaker of power control module.
3. Turn on the inverter.
4. Power on the energy storage battery unit (Shortly press the ON/OFF button for 1 second).

### 5.3.2 Black start process

Black start means that after the whole power grid is shut down due to failure, the system is completely powered off and in a completely "black" state. At this time, through the start-up of the units with self-start capability in the system and the external power supply, the units without self-start capability are driven, the recovery scope of the system is gradually expanded, and the recovery and power supply of the whole system are finally realized.

1. Close the circuit breaker on the DC side of the inverter and the DC breaker between the inverter and the battery unit.
2. Press the ON button for 1 second, observe the status lamp of the energy storage battery unit and check the operation state. After the inverter is started, the battery unit will operate normally.

## 5.4 Shutdown process

System power-off steps:

1. Turn off the inverter.
2. Power off the energy storage battery unit.
3. Open the circuit breaker of power control module.
4. Open DC breaker (if any) configured between inverter and battery unit.

## 6 Storage and Recharging

### 6.1 Battery storage requirements

During storage, the battery shall be placed correctly according to the identifiers of the packing box, and shall not be placed upside down or sideways.

When the battery packing boxes are stacked, the stacking requirements on the outer packaging shall be met.

5. The battery shall be handled with care. It is strictly prohibited to damage the battery.
6. Requirements for storage environment:
  - Ambient temperature:  $-10^{\circ}\text{C}\sim 55^{\circ}\text{C}$ , recommended storage temperature:  $20^{\circ}\text{C}\sim 30^{\circ}\text{C}$ .
  - Relative humidity: 5%RH~80%RH.
  - Dry, ventilated and clean.
  - Avoid contact with corrosive organic solvents, gases and other substances.
  - Avoid direct sunlight.
  - The distance from the heat source shall not be less than two meters.
7. During storage, the battery must be disconnected from the external connection. If there is an indicator on the battery panel, the indicator shall be off.
8. The warehouse keeper shall make monthly statistics on the battery storage, regularly report the battery inventory to the planning management team, and timely arrange recharging for batteries that have been stored for nearly 6 months.
9. When the stored batteries are shipped, the principle of FIFO (First in First out) should be followed.
10. After the battery production test is completed, it needs to be recharged to a minimum of 50% SOC before storage.

## 6.2 Recharging cycle and requirements

In principle, it is not recommended to store the battery for a long time. Long-term deep discharge will cause battery damage, so it shall be used in time. Stored batteries shall be recharged according to the following temperature and cycle requirements.

Table 6-1 Recharging Cycle

Storage temperature range	Actual storage temperature	Recharging Cycle	Remarks
-10°C < T ≤ 45°C	T ≤ -10°C	Not allowed	Within the recharging cycle: <ul style="list-style-type: none"> <li>No treatment is required, and it shall be used as soon as possible;</li> <li>Recharge in time when it's time to recharge;</li> <li>The total storage time shall not exceed the maintenance period.</li> </ul>
	-10°C < T ≤ 45°C	6 Months	
	45°C < T	Not allowed	

### The requirements for recharging are as follows:

- Before the battery is recharged, the appearance of the battery needs to be inspected, and only the qualified battery can be recharged. If the battery is deformed, damaged or leaking, it shall be scrapped directly, storage and recharging shall not be considered.
- The storage time is calculated from the latest charging time marked on the recharging label on the battery external package. After the battery is recharged to the standard, the latest charging time and the next charging time (next charging time = latest charging time + recharging cycle) on the recharging label shall be updated.
- When the batteries are during storage, the maximum allowable recharging time is 3. For example: recharging once every 6 months, with a maximum of

3 times allowed. It is recommended that the battery be scrapped if the maximum allowable period and times are exceeded.

---

**Note:**

- Long-term storage of lithium batteries will cause capacity loss. After lithium batteries are stored at the recommended storage temperature for 6 months, the irreversible capacity loss is generally 3%~8%. If the customer carries out the discharge test and acceptance according to the specification, there is a risk that the battery whose storage capacity is less than 100% of the rated capacity will fail the test.
- The after-sales service personnel must be contacted to complete the recharging operation.

---

### 6.3 Recharging operation

It can provide 5kW power to charge the battery through the supporting inverter, and support the simultaneous recharging of 1 recharge unit (support 2 battery extension modules under standard conditions, and support up to 4 battery extension modules. However, recharging over 2 battery extension modules is not recommended);

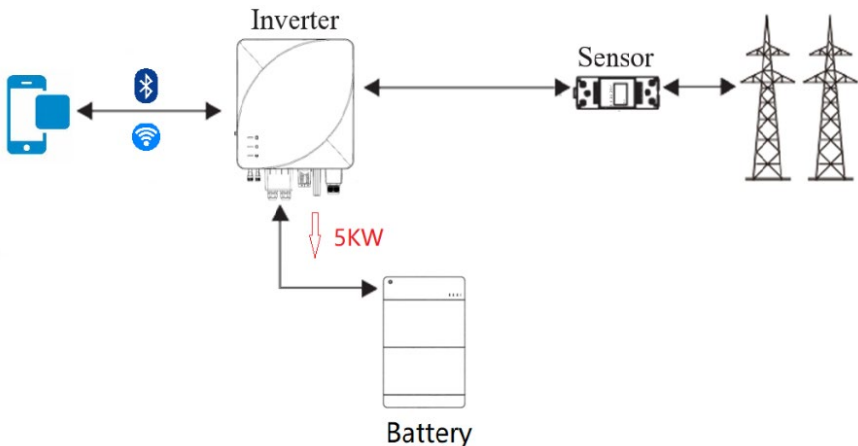

Figure 6-1 Single-phase Electricity Recharging Scenario

## 6.4 Battery power-on and commissioning steps

---

### NOTICE!



- The charging process must be monitored by someone on site to prevent abnormal phenomena.
- If abnormalities such as bulging and smoking occur during charging, stop charging immediately and scrap the battery directly.
- The recharging operation must be carried out by professionals with trained skills.
- After the energy storage switch is closed, power on the inverter. Refer to the quick guide of the corresponding model for the power-on steps of the inverter.
- When SOC of the battery is 0%, the energy storage battery unit cannot be activated by long pressing the black start button, and the energy storage battery unit can only be started after the DC and AC of the inverter are powered on.
- During recharging, SOC of the battery is recommended to be recharged to 50%.

---

The battery power-on and commissioning steps are as follows:

1. Close DC Breaker (if any) configured between inverter and battery unit.
2. Close the circuit breaker of power control module.
3. Turn on the inverter.
4. Power on the energy storage battery unit (Shortly press the ON/OFF button for 1 second).
5. Make use of inverter to discharge the energy storage battery unit with 0.5\*charging rate until the battery unit reaches low voltage protection
6. Make use of inverter to charge the energy storage battery until the SOC of battery unit reaches 50%.
7. Power off the inverter and battery unit by referring to the section 5.4 shutdown process.

## 7 Maintenance and Replacement

---

### WARNING!

- Before starting product maintenance, it is necessary to stop running the inverter and disconnect the AC circuit breaker connected to the power grid and the PV input connection on the DC side.
- During the operation of the energy storage battery unit, if only the circuit breaker of the energy storage battery unit is disconnected, the system cannot be completely powered off. At this time, the energy storage cannot be maintained.
- After the system is powered off, there is still residual electricity and heat in the chassis, which may cause electric shock or burns. Therefore, after the system is powered off for 5 minutes, wear protective gloves before operating the energy storage system. Ensure that all the indicators of the energy storage are off, and then the maintenance operation of the energy storage can be carried out.
- The maintenance instructions described in this manual are only applicable to qualified maintenance personnel.
- In order to reduce the risk of electric shock, do not carry out other maintenance operations other than those specified in this manual unless you are explicitly authorized and qualified for maintenance.



## 7.1 Maintenance precautions

You can use ladders to remove power control module or battery expansion unit if it's necessary, as shown below.

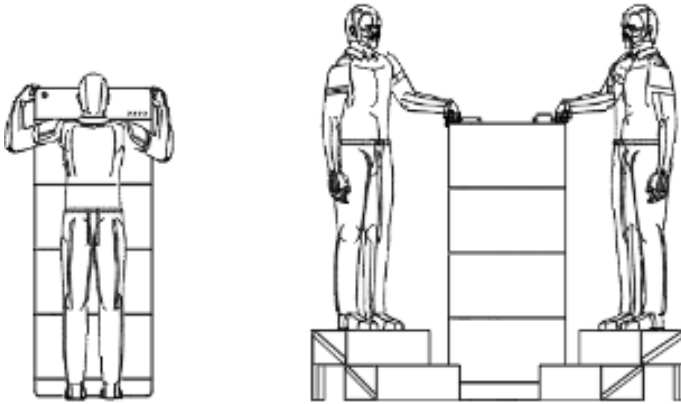

Fig. 7-1 Remove power control module or battery expansion unit.

Please follow the following precautions if you need to use ladders to remove power control module or battery expansion unit.

- Wooden or fiberglass stairs should be used when electric climbing operations may be involved.
- Before using the ladder, ensure that the ladder is in good condition and meets the required load weight. Overweight is prohibited.
- When using a ladder, the wide foot of the ladder should face down, and adopt protective measures at the bottom of the ladder to prevent slipping.
- The ladder should be placed in a stable place.
- Someone must hold the ladder when working.
- When climbing the ladder, keep your body steady and ensure that your weight does not deviate from the edge of the ladder, to ensure safety.

## 7.2 Maintenance items and cycle

To ensure the long-term good operation of the energy storage battery unit, it is recommended to carry out routine maintenance according to the table below.

Inspection Contents	Inspection Method	Maintenance Cycle
System cleaning	Regularly check whether the cooling fins are covered with dust and dirt.	Once half a year to once a year.
System operation state indicator	<ul style="list-style-type: none"> <li>• Observe whether the appearance of energy storage is damaged or deformed.</li> <li>• Listen for any abnormal sounds during the operation of the energy storage.</li> <li>• During energy storage operation, check whether the parameters of energy storage are set correctly.</li> </ul>	Once half a year
Electrical connection	<ul style="list-style-type: none"> <li>• Check for fall-off or looseness of the cable connection.</li> <li>• Check whether the cable is damaged, focusing on checking whether the skin of the cable in contact with the metal surface is cut.</li> <li>• Check whether the unused DC input terminal, energy storage terminal, COM interface and waterproof cover are locked.</li> </ul>	Half a year after the first commissioning, and once half a year to once a year thereafter
Grounding reliability	Check whether the ground cable is reliably grounded.	Half a year after the first commissioning, then once every half a year to a year.

Table 7-1 Maintenance List

## 7.3 Fault List

### 7.3.1 Troubleshooting of LED indicator

LED Lamp Fault Status	Troubleshooting
All lamps are out	1. Turn the circuit breaker to the "OFF" position 2. Click the ON button and observe the indicator status
The operation state lamp is off or the alarm lamp is on	See Table 7-3 for troubleshooting

Table 7-2 LED Indicator Fault

### 7.3.2 List of faults

When the energy storage battery unit fails, such as output short circuit, battery overvoltage, battery undervoltage, temperature too high, temperature too low, differential pressure too large, and internal fault of the machine, the energy storage battery unit will automatically stop.

Before contacting the after-sales service, you can quickly locate the cause of the fault according to the faults listed in Table 7-3, and handle it according to the recommended treatment method. There are three main fault types: alarm, protection and fault, as shown in the following table.

Remote monitoring of battery status is achieved via inverter monitoring app.

Fault Indication	Fault Description	Fault Cause	Handling Suggestions
Alarm indicator flashing	Discharge undervoltage	The cell voltage is below the undervoltage protection threshold.	There is a risk of over-discharge, so the user shall stop discharging and arrange charging
	Charging overvoltage	The cell voltage exceeds the protection threshold.	There is no safety threat, the user shall stop charging, and the battery will become normal after standing or discharging.
	External CAN fault	inverter communication loss	There is no security threat; check whether the inverter and the battery communication terminal are well connected;

			After confirming that the communication line is well connected, it is still unable to communicate, the user shall contact the installation personnel for maintenance and troubleshooting.
	Temperature too high	The battery temperature is higher than the high temperature protection threshold	<ol style="list-style-type: none"> <li>1. The user shall stop charging or discharging, and the battery will become normal after standing;</li> <li>2. Check whether there is a heating source in the battery environment, and remove it if any;</li> <li>3. Check the charging and discharging data of inverter, and check whether there is any fault in inverter;</li> <li>4. If protection occurs many times, the user shall contact the installation personnel for maintenance and troubleshooting.</li> </ol>
	Temperature too low	The battery temperature is lower than the low temperature protection threshold	<ol style="list-style-type: none"> <li>1. The user shall stop charging or discharging, stand the battery and wait for it to become normal;</li> <li>2. Check whether the battery environment meets the installation requirements;</li> <li>3. Check the battery configuration and whether there is a heating film;</li> <li>4. If protection occurs many times, the user shall contact the installation personnel for maintenance and troubleshooting;</li> </ol>
Alarm indicator normally on	Short circuit protection	External short circuit of battery	There are potential safety hazards, so the user shall stop using the battery and contact the installation personnel to repair inverter and the battery
	Pre-charging overtime		
	Main circuit failure	BMS main power supply circuit failure	There are potential safety hazards, so the user shall stop using the battery. The user shall contact the installation personnel to repair the battery

Table 7-3 Fault Information

Code	Fault Type	Failure Causes
Flash 1	Circuit breaker disconnection	Tripped level 3 overcurrent, relay sticking
Flash 2	Voltage difference excessive	The difference between the highest and lowest battery voltage exceeds the set threshold
Flash 3	Battery failure	There is a module dropout or the total pressure collected at both ends of the battery and the sum of all battery voltages exceeds the set threshold
Flash 4	Slave failure	BSU (Battery Management System) fails
Flash 5	Cell overvoltage	The highest cell voltage exceeds the set threshold
Flash 6	Cell undervoltage	The lowest cell voltage exceeds the set threshold
Flash 7	High temperature excessive	The highest temperature exceeds the set threshold
Flash 8	Low temperature excessive	The lowest temperature exceeds the set threshold
Flash 9	Overcurrent excessive	The current exceeds the set threshold
Flash 10	Inverter communication interruption	No communication with the inverter (Power System Communication), unable to effectively control and manage
Flash 11	Output current too high	The current exceeds the system allowable value, potentially affecting the safe operation of equipment
Flash 12	Insulation failure	There is a leakage between the battery and the shell, which may pose a safety hazard
Flash 13	EEPROM failure	The storage chip of BMU (Battery Management Unit) fails, affecting the accuracy of data reading and processing
Flash 14	Other failures	-

## 8 Technical Data

Parameters		ESSR-05KL1	ESSR-10KL1	ESSR-15KL1	ESSR-20KL1
Voltage	Voltage Level (V)	LV 44.8~57.6			
C-Rate & Power	C-Rate	0.5			
	Max Charge/Discharge Power(kW)	2.5	5	6	6
Max Continue Current(A)		50	100	120	120
Energy	DOD (%)	100%			
	Battery System Rated Capacity (kWh)	5.12	10.24	15.36	20.48
Life	EOL (%)	70			
	Warranty (years)	10			
Dimension & Extension	Width (mm)	670 ± 1			
	Depth (mm)	178 ± 1			
	Hight (mm)	650	1020	1390	1760
	Weight of the smallest module to install (kg)	63 ± 1	109 ± 1	155 ± 1	202 ± 1
	ESS Units Maximum Energy	5.12	10.24	15.36	20.48
	Installation	Floor Mount & Wall Mount			
	Product Parallel Extension	Up to 3 Units (12Packs, 10kW, 61.44kWh)			
	Protection	IP 65(Unit)			

Authentication	Authentication level	IEC 62619, IEC 63056, IEC 62040-1, IEC/UL 60730-1 annex H, CE EMC, EN 61000-6-1/-3, VDE 2510-50, UKCA, UN38.3
Temperature	Working Temperature (°C)	Charge: 0~50 Discharge: -10~50
Others	Altitude	≤3000
	Humidity	Up to 95% RH
BMS	Heating	Optional
	Black Start Mode	Yes
	Sleep Mode	Yes
	Pack Fire Control	Optional
	Master/Slave Marking	Auto
	Address Management	Auto

Control Module	CPS ECD51
Dimension(W/D/H)	670/178/180mm
Weight	8.5 kg
Max current	120A
Rated Voltage:	51.2 Vdc
Max Voltage:	57.6 Vdc

Battery Module	CPS EBM016100LF-L
Dimension(W/D/H)	670/178/370mm
Weight	44 kg
Nominal energy	5.12kWh
Nominal voltage	51.2V
Operating voltage range	44.8~57.6 V

## 9 Quality Assurance

### 9.1 Immunity from liabilities

When installing, operating and maintaining the equipment, read this manual first and follow all safety precautions marked on the equipment and in the manual. The "Instructions", "Notes", "Warnings" and "Dangers" in this manual do not represent all safety matters to be observed, but only serve as a supplement to all safety precautions. Chint Power does not assume any responsibility due to violating the requirements for general safety operation or violating the design, manufacturing and equipment safety operation standards.

The equipment shall be used in an environment that meets the requirements of design specifications, otherwise it may cause equipment failure, resulting in abnormal equipment function or component damage, personal safety accidents, property losses, etc., which are not within the scope of equipment quality assurance. The equipment shall be installed, operated and maintained in accordance with local laws, regulations and specifications. The safety precautions in this manual are only used as a supplement to local laws, regulations and specifications.

Chint Power is not responsible for any of the following situations.

- Operation is not carried out in accordance with the use conditions described in this manual.
- The installation and use environment does not conform to the provisions of relevant international or national and regional standards.
- Unauthorized disassembly, alteration of the product or modification of the software code.
- Failure to operate according to the operating instructions and safety warnings in the products and documents.
- Equipment damage caused by abnormal natural environment (force majeure, such as earthquake, fire, storm, flood, debris flow, etc.).
- Transportation damage caused by the customer's own transportation.
- Damage caused by storage conditions that do not meet the requirements of

product documentation.

- Damage to the hardware or data of the device due to negligence, improper operation or intentional damage by the customer.
- System damages caused by third parties or customers, including handling and installation that do not meet the requirements of this manual, as well as damages caused by adjustment, alteration or removal of identification signs that do not meet the requirements of this manual.

## 9.2 Quality terms

Please refer to relative quality warranty manual.

If you have any questions about energy storage battery unit, please contact us, and we will be very happy to serve you.

Shanghai Chint Power Systems Co., Ltd.

Headquarters: Building 4, No. 3255, Sixian Road, Songjiang District, Shanghai,  
China

Switchboard: +86-21-3779-1222

Fax: +86-21-3779-1222-866003

Website: [www.chintpower.com](http://www.chintpower.com)

Service hotline: +86-21-3779-1222-866300

E-mail: [service.cps@chint.com](mailto:service.cps@chint.com)