

# Installation and Operation Manual

## for CPS Smart Power Controller

### SAU100J0



**Shanghai Chint Power System Co., Ltd.**

# Table of Contents

<b>0</b>	<b>Preface .....</b>	<b>3</b>
<b>1</b>	<b>IMPORTANT SAFETY INSTRUCTIONS .....</b>	<b>4</b>
1.1	Symbols and meanings in this document .....	4
1.2	Markings and Meanings on the Device .....	4
1.3	Safety Precautions of Operating the Product .....	5
<b>2</b>	<b>General Introduction.....</b>	<b>7</b>
2.1	Structure and Nameplate .....	7
2.2	System Schematic Diagram .....	10
<b>3</b>	<b>Mechanical Installation .....</b>	<b>11</b>
3.1	Unpacking for Inspection.....	11
3.2	Installation Requirements.....	11
3.3	Installation Procedures.....	12
<b>4</b>	<b>Electrical Connection .....</b>	<b>14</b>
4.1	Recommended Tools and Usages.....	14
4.2	Cable Specification.....	14
4.3	Electrical Connection.....	15
<b>5</b>	<b>Electricity Meter Setting.....</b>	<b>22</b>
5.1	Set Wiring Mode.....	22
5.2	Set Current Ratio and Voltage Ratio .....	22
5.3	Set Communication Address and Baud Rate .....	23
5.4	Set Communication Protocol.....	23
<b>6</b>	<b>Anti-Reflux Configuration .....</b>	<b>25</b>
6.1	Anti-Reflux Configuration via Mobile App .....	25
6.2	Anti-Reflux Configuration via Web Interface.....	45
<b>7</b>	<b>Maintenance .....</b>	<b>50</b>
7.1	Regular Maintenance .....	50
7.2	Troubleshooting.....	50
<b>8</b>	<b>Technical Data.....</b>	<b>52</b>

## 0 Preface

Thank you for choosing SAU100J0 Smart Power Controller developed by Shanghai Chint Power System Co., Ltd. (hereinafter referred to as "CHINT").



### **IMPORTANT!**

Please read this manual carefully and make sure that you have understood all the contents thoroughly before you start any operation.

### **Main Contents**

Safety precautions, device overview, installation, operation and maintenance, technical data are mainly introduced in this manual.

### **Target Reader**

This manual is applicable to the work staff of wiring, installation, maintenance and daily management of the product.

### **Manual Management**

Please store this manual together with related documents of other device components, and make sure keep it at hand for quick reference and easy use.





### **Copyrights**

CHINT reserves all rights in this manual. Any reproduction, disclosure or copy in whole or in part is forbidden without prior written authorization. CHINT doesn't accept any responsibilities whatsoever for potential errors or possible lack of information in this document.



# 1 IMPORTANT SAFETY INSTRUCTIONS



Please read this user manual carefully before the installation and operation of this product. CHINT reserves the right to refuse warranty claims for equipment damages if users fail to install the equipment according to the instructions in this manual.

## 1.1 Symbols and meanings in this document



Symbol	Meanings
	<b>DANGER!</b> DANGER indicates a hazardous situation with high level of risk which, if not avoided, will result in death or serious injury.
	<b>WARNING!</b> WARNING indicates a hazardous situation with medium level of risk which, if not avoided, could result in death or serious injury.
	<b>CAUTION!</b> CAUTION indicates a hazardous situation with low level of risk which, if not avoided, could result in minor or moderate injury.
	<b>NOTICE!</b> NOTICE indicates a hazardous situation which, if not avoided, could result in equipment working abnormally or property loss.
	<b>IMPORTANT!</b> IMPORTANT indicates important supplementary information or provides skills or tips that can be used to help you solve a problem or save you time.



## 1.2 Markings and Meanings on the Device

Symbol	Meanings
	<b>HIGH VOLTAGE!</b> Danger to life due to high voltage! All work on the device must only be performed by qualified personal as described in this document.
	<b>HOT!</b>

	The equipment is designed according to international safety standards, but surfaces can become hot during operation. DO NOT touch the peripheral surfaces during or shortly after operation.
	<b>EARTH GROUND!</b> This symbol marks the location of grounding terminal, which must be securely connected to the earth through the PE (protective earth) cable to ensure operational safety.
	<b>RoHS SYMBOL</b> In accordance with 2011/65/EU regulations, the inverter imposes restrictions on the use of specific hazardous substances in electrical and electronic equipment.

### 1.3 Safety Precautions of Operating the Product

Symbol	Meanings
	<b>DANGER!</b> <ul style="list-style-type: none"> <li>Touching the wiring terminals inside the device may result in death by electric shock!</li> <li>DO NOT touch the terminals or conductors connected with PV modules or PV inverters, which may result in death by electric shock!</li> </ul>
	<b>WARNING!</b> <ul style="list-style-type: none"> <li>All the installation and wiring connections should be performed only by qualified technical personnel.</li> <li>Make sure both the AC and DC sources are disconnected, and the shell of device is securely grounded to avoid electric shock during maintenance or installation.</li> <li>DO NOT touch live or exposed parts of the input and output sides to avoid electric shock when checking or maintaining the device.</li> </ul>
	<b>CAUTION!</b> <ul style="list-style-type: none"> <li>Handle the Product carefully to prevent falling off due to its weight!</li> <li>Check the device and make sure there is no problem with the installation before putting it into operation!</li> <li>Connect the wires to avoid short circuit hazard, to ensure personal safety and the normal operation of the device.</li> </ul>

	<ul style="list-style-type: none"><li>• Although the Product is certified to international safety standards, it will become hot during operation. DO NOT touch the hot parts of the device during operation.</li></ul>
	<p><b>NOTICE!</b></p> <ul style="list-style-type: none"><li>• Follow all the wiring and safety instructions of the Product.</li><li>• All the wiring and operation must conform to the related local standard requirements of the device.</li></ul>
	<p><b>IMPORTANT!</b></p> <ul style="list-style-type: none"><li>• The device nameplate contains important information of the device, such as model, serial number and detailed parameters.</li><li>• If there is any problem or malfunction of the device during operation, please contact our after-sales center and provide the serial number. Our service personnel can provide timely service for you.</li><li>• Please keep the nameplate intact.</li></ul>

## 2 General Introduction

### 2.1 Structure and Nameplate

#### 2.1.1 Appearance and Dimensions

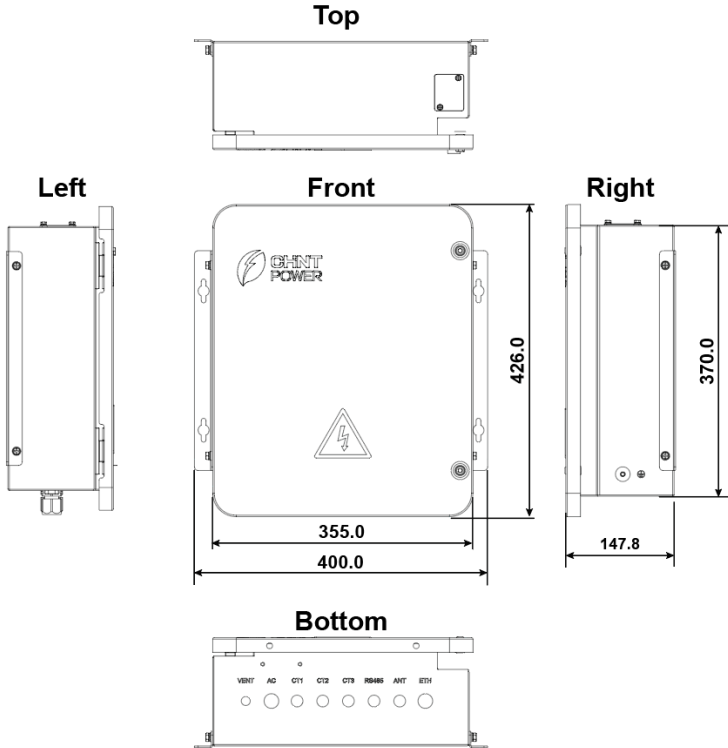

Figure 2-1 Appearance and Dimensions

## 2.1.2 Bottom Connections

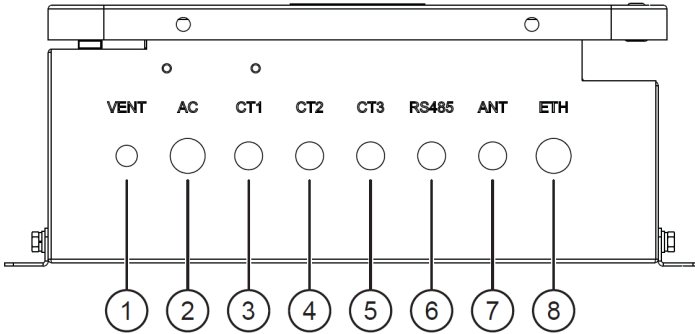

Figure 2-2 Bottom connections of the Smart Power Controller

No.	Terminal	Usage
1	Vent	Balance pressure difference
2	AC	AC cable outlet
3	CT1	Current transformer cable outlet
4	CT2	
5	CT3	
6	RS485	RS485 cable outlet
7	ANT	Feeder line outlet for Bluetooth suction cup antenna
8	ETH	Ethernet cable outlet

Table 2-1 Bottom Connections

### 2.1.3 Internal Structure

After opening the controller, you can find the following main components as shown below.

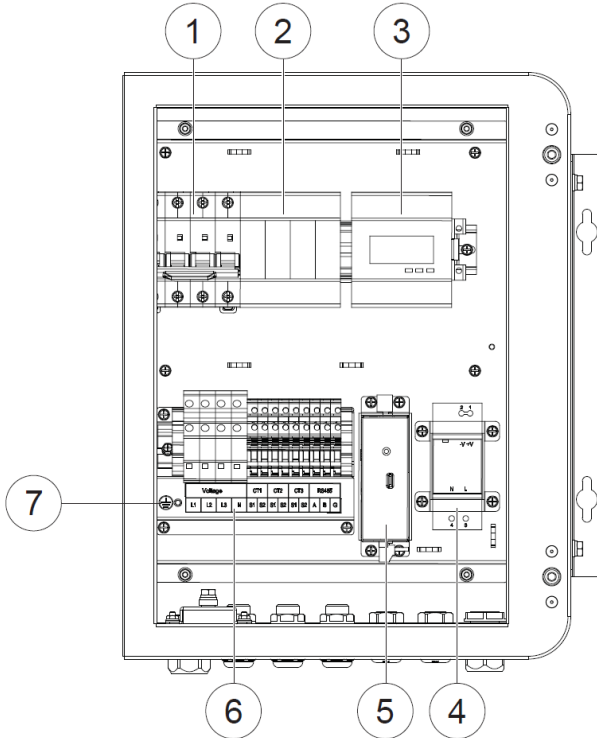

Figure 2-3 Overview of internal structure and nameplate

No.	Component Name
1	Miniature circuit breaker
2	AC surge protector device (SPD)
3	Electricity meter
4	Power supply module
5	Communication module (with smart Ethernet card)
6	Terminal block (Interface terminal assembly)
7	Internal grounding point

Table 2-2 Main Components

## 2.2 System Schematic Diagram

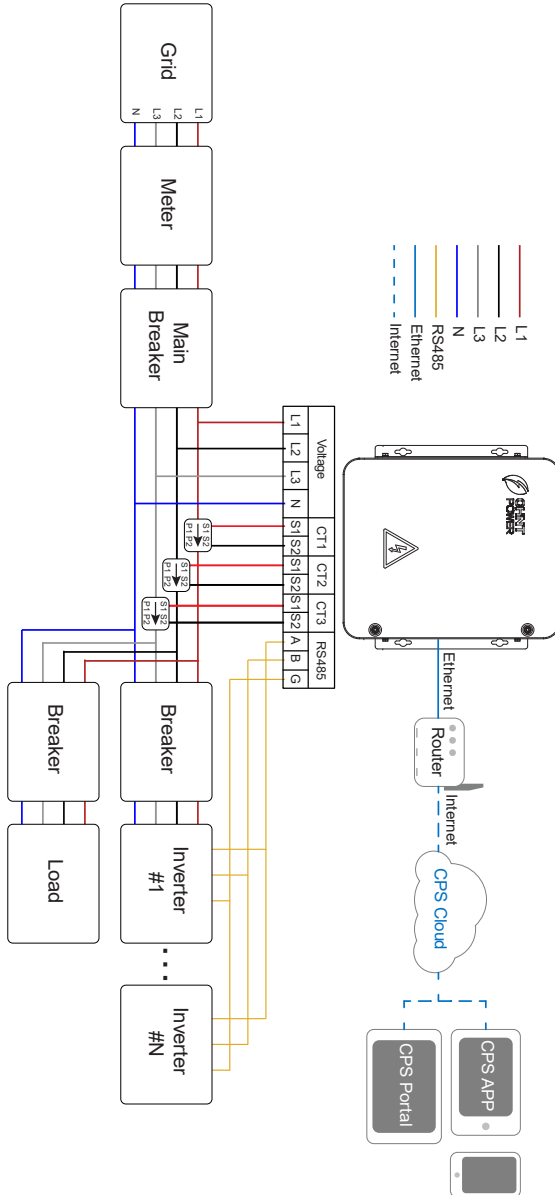

Figure 2-4 System Diagram

### 3 Mechanical Installation

#### 3.1 Unpacking for Inspection

Check the product for any obvious damages or if the items in the delivery list are complete before performing installation. Contact your supplier immediately if any problem is found. The delivery list is as below:

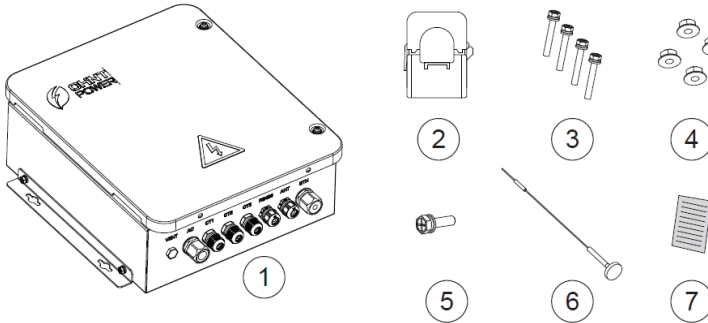

Figure 3-1 Delivery List

No.	Accessories	Type	QTY (pcs)
1	Smart power controller	SAU100J0	1
2	Current transformer (CT)	NCTK-36 300A	3
3	Combination screw	M6x42	4
4	Flange nut	M6	4
5	Combination screw	M5x12	1
6	Suction cup antenna	YE0016AA	1
7	Quick installation guide	/	1

Table 3-1 Delivery List Description

#### 3.2 Installation Requirements

##### 3.2.1 Recommended Clearances

During planning and installing the controller, appropriate clearances as indicated below shall be reserved to facilitate access, maintenance, and to prevent cable strain or physical damage.

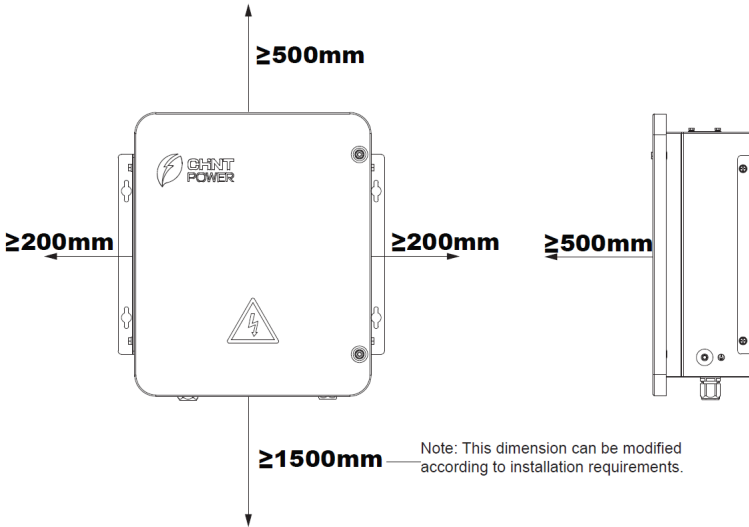

Figure 3-2 Recommended Clearances

### 3.2.2 Installation Environment Requirements

It is recommended to install the controller under a shelter to avoid direct sunlight, rain and snow accumulation, to prevent from increasing controller failures or reducing its service life.

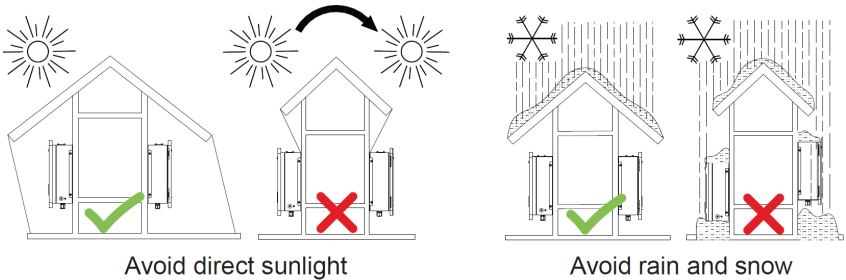

Figure 3-3 Installation Environment Requirements

### 3.3 Installation Procedures



**WARNING!**

- All the installation steps should be performed only by qualified technical personnel.

1. Use a marker to mark drilling points for four 8mm diameter holes on the support structure (wall, steel rack, etc.)

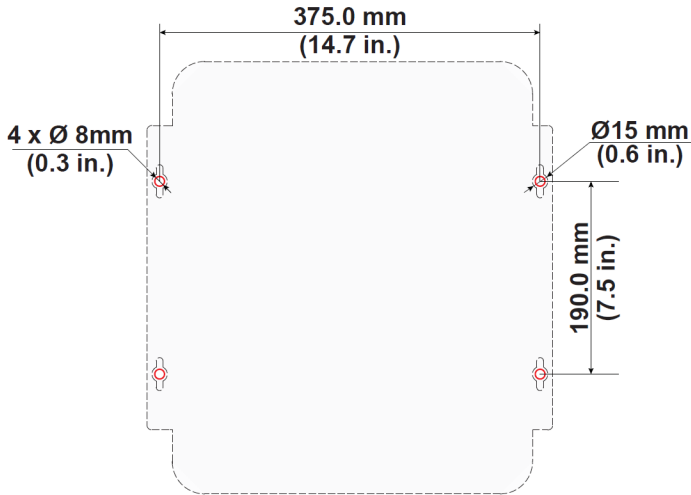

Figure 3-4 Mark Drilling Points

2. Drill four holes at the marked positions. Tool: Electric drill with  $\Phi 8.0\text{mm}$  drill bit.
3. Align the four mounting holes on the controller with the four holes on the support structure. Secure the controller using the M6x42 screws and M6 flange nuts, then tighten them firmly. Tool: 10 mm hex socket wrench. Torque: 8.3 - 10 N.m.

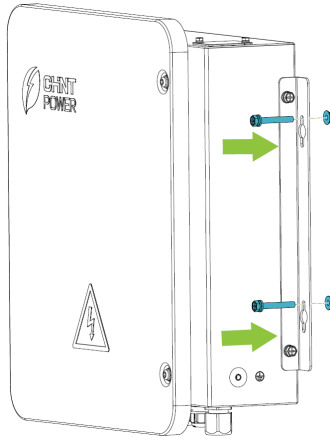

Figure 3-5 Secure the Controller

## 4 Electrical Connection

### WARNING!



- Check all the input and output cables or terminals to ensure there's no voltage before electrical connection to avoid electric shock!
- All the installation steps should be performed only by qualified technical personnel.
- Before wiring, switch off the miniature circuit breaker inside the controller and ensure that all upstream and downstream circuits connected to the controller are completely de-energized.



### CAUTION!

Connect the cables following strictly the polarities marked on the device to avoid short circuit hazards.

### 4.1 Recommended Tools and Usages

Tool	Usage	Torque value
5mm hex socket wrench	Open front cover	N/A
	Secure front cover	3 N · m
PH2 Phillips screwdriver	Fix AC terminal	1.6 N·m
	Fix internal grounding terminal	1.3 N·m
No.10 socket wrench	Fix external grounding terminal	5.9 N·m
#1 flathead screwdriver	Fix CT terminal	0.6 N·m
	Fix RS485 terminal	
Wire stripper, diagonal plier, and crimping plier	Cable preparation	N/A

Table 4-1 Recommended Tools and Usages

### 4.2 Cable Specification

Cable	Type	Cable Outer Diameter	Cross-Sectional Area (CSA)
AC cable	Outdoor four-core copper wire	6mm ~ 15mm	<ul style="list-style-type: none"> <li>• L1/L2/L3/N: 4mm<sup>2</sup>~10 mm<sup>2</sup></li> <li>• PE: 1mm<sup>2</sup>~6mm<sup>2</sup></li> </ul>
	Outdoor single-core copper wire	4mm ~ 6mm	
Grounding cable	Outdoor copper-core wire	6.4mm ~ 7.3mm	6 mm <sup>2</sup> ~10 mm <sup>2</sup>
RS485 cable	Double-layer insulated cable	4.5mm ~6mm	3x0.2mm <sup>2</sup> ~0.75 mm <sup>2</sup>

## 4.3 Electrical Connection



### IMPORTANT!

Before wiring, switch off the miniature circuit breaker inside the controller and ensure that all upstream and downstream circuits connected to the controller are completely de-energized.

#### 4.3.1 Wiring Overview of Smart Power Controller

The controller's internal wiring is factory-installed before shipment. Field installation only requires terminating wires to the terminal blocks based on the wiring labels. The following figure provides an overview of the terminal block wiring.

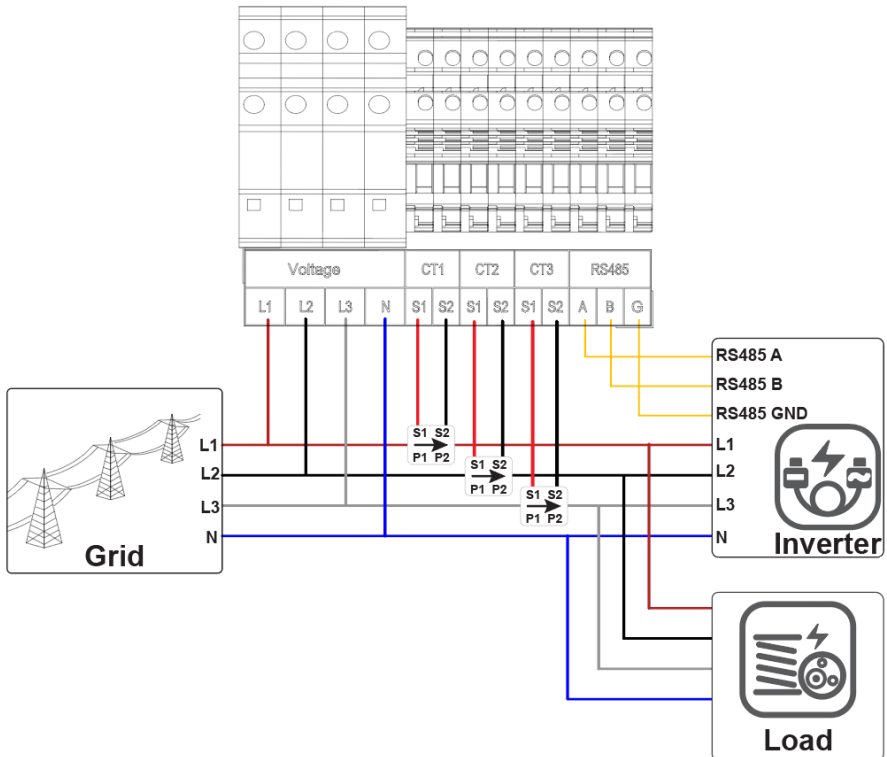

Figure 4-1 Terminal Wiring of Smart Power Controller

### 4.3.2 Open Front Cover

1. Loosen the two screws to open the front cover.

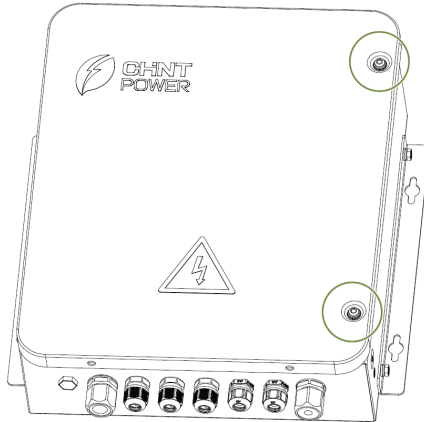

Figure 4-2 Open the Front Cover

2. Use the support rod to hold the front cover, ensuring it is firmly snapped into the slot.

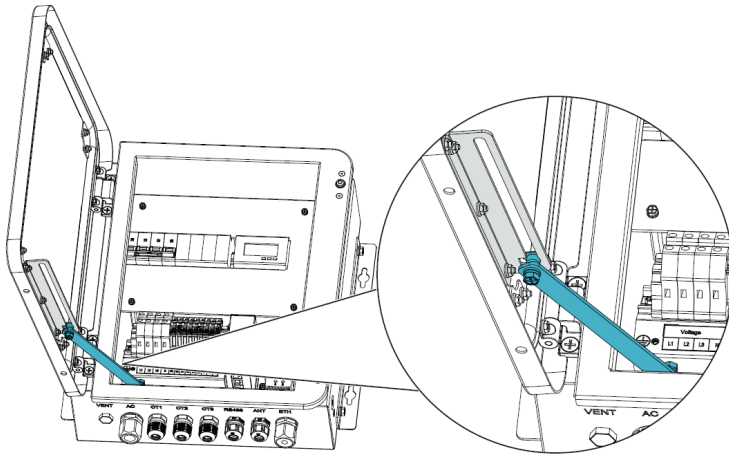

Figure 4-3 Hold the Front Cover

### 4.3.3 Grounding (Protection Earthing)

The grounding cable must be connected using at least one of the following methods:

- **Internal Grounding:** Connect grounding cable to the grounding hole located at the lower-left inside the controller using the pre-installed M4x10 screw.

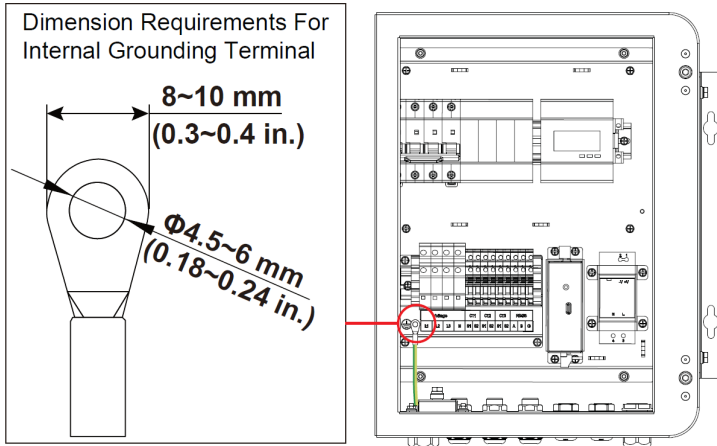

Figure 4-4 Internal Grounding

- **External Grounding:** Connect grounding cable to the grounding hole is located in the lower-right corner outside the controller using the M5x12 screw.

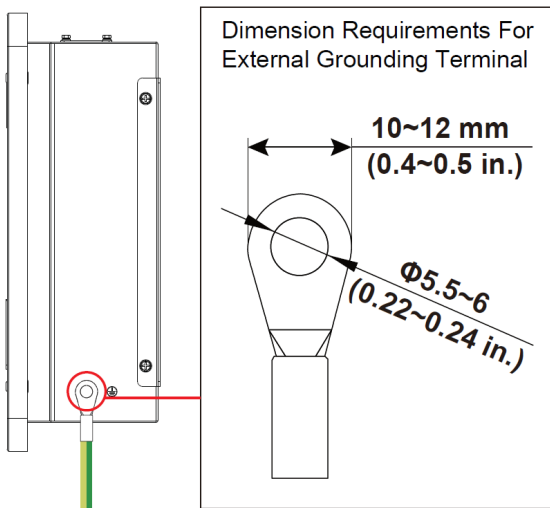

Figure 4-5 External Grounding

Note: After wiring, the external PE point needs to be coated with glue or paint. Other sizes of grounding cables that meet local standards and safety regulations can also be used for grounding connections. But CHINT shall not be liable for any damage caused.

### 4.3.4 AC Cable Wiring

- Strip the jacket and insulation layer of the AC cable to the appropriate length, exposing the conductors. Insert the conductors into the tube terminals until contacting the terminal's barrel end, align the cable insulation edge with the terminal's crimping wings, then crimp firmly to secure the connection. Note: The tube terminals are customer-supplied, compatible model is E6010.

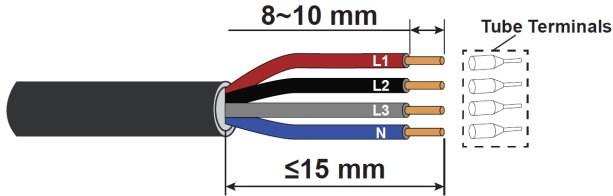

Figure 4-6 Crimp the AC Terminals

- Loosen the locking nut of AC cable gland, and thread the crimped AC cable through the AC outlet. Insert the phase lines (L1/L2/L3) and neutral line (N) into the corresponding terminals. Tighten the terminal screws. Finally, re-tighten the gland nut.

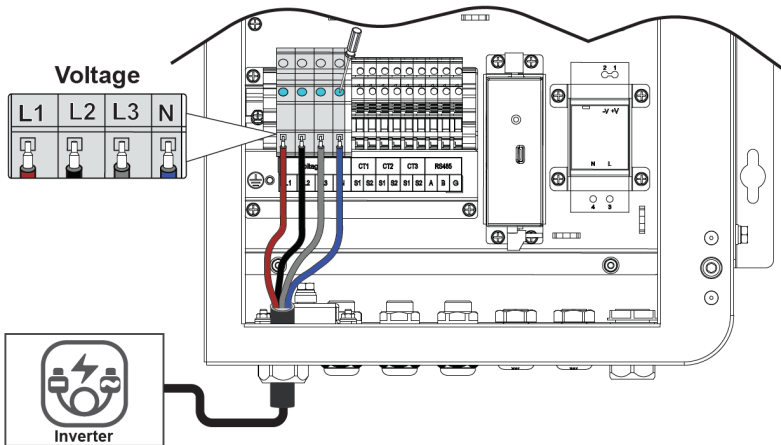

Figure 4-7 Connect the AC Cable

### 4.3.5 CT Cable Wiring

- Loosen the locking nuts of CT cable gland, and thread the pre-crimped CT cable through the CT outlet. Insert the CT wires into the corresponding terminals. Tighten the terminal screws. Finally, re-tighten the gland nuts.

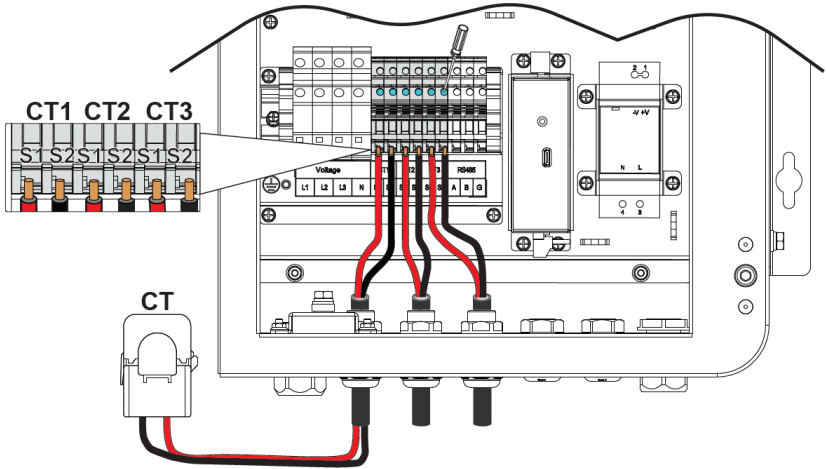

Figure 4-8 Connect the CT Cable

#### 4.3.6 RS485 Cable Wiring

1. Strip the jacket and insulation layer of the RS485 cable to the appropriate length, exposing the conductors. Insert the conductors into the tube terminals until contacting the terminal's barrel end, align the cable insulation edge with the terminal's crimping wings, then crimp firmly to secure the connection. Note: The tube terminals are customer-supplied, compatible models are E0206~E0506.

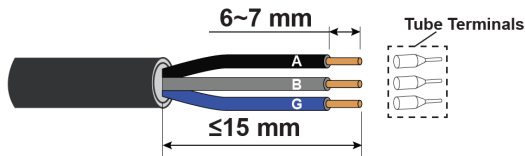

Figure 4-9 Crimp the RS485 cable

2. Loosen the locking nut of RS485, and thread the crimped RS485 cable through the RS485 cable outlet. Insert the RS485 wires into the corresponding terminals and tighten the terminal screws. Finally, re-tighten the gland nuts.

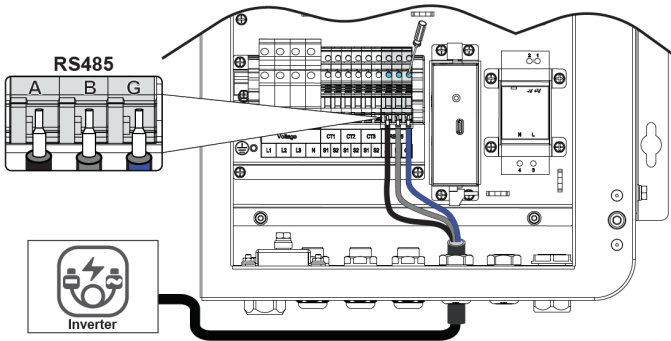

Figure 4-10 Connect the RS485 Cable

### 4.3.7 Install Suction Cup Antenna

The communication module inside the controller supports both wired (via Ethernet cable) and wireless (via Bluetooth) communication.

To enable Bluetooth operation:

1. Thread the Bluetooth cable through the ANT hole, then use hand to secure the mounting nut to the module's Bluetooth antenna terminal.

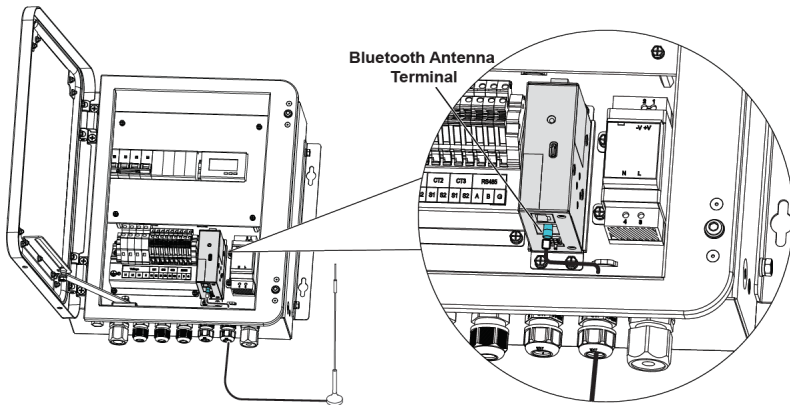

Figure 4-11 Connect the Bluetooth cable

2. Attach the antenna's magnetic base to the surface on the controller top.

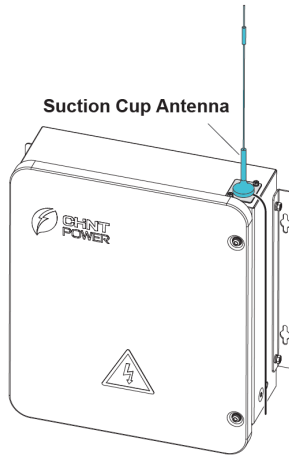

Figure 4-12 Attach the Suction Cup Antenna

---

**IMPORTANT!**



After completing all wiring steps, secure the front cover by tightening all screws to prevent water ingress. Ensure that all waterproof terminals are firmly fastened, and seal any gaps at the bottom of the terminals with firestop putty.

---

## 5 Electricity Meter Setting

Button description:

- [SET] button represents confirmation or cursor shift (when entering the number).
- [ESC] button represents exit.
- [→] button represents add.
- [←] button represents reduce.

The default password is 701.

### 5.1 Set Wiring Mode

Three-phase four-wire (3P4W) is provided as the default wiring mode.

The wiring mode (3P4W or 3P3W) and the channel access type (direct connection or CT connection) can be configured if required by the site wiring.

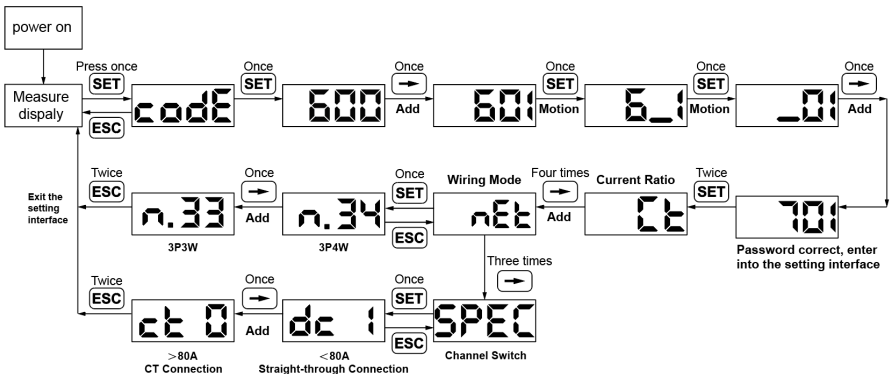

Figure 5-1 Set the Wiring Mode

### 5.2 Set Current Ratio and Voltage Ratio

The current ratio and voltage ratio are **mandatory** parameters and must be configured:

- Current ratio: Configure the current ratio according to the connected current transformer (CT) specifications.
- Voltage ratio: Set the voltage ratio to 1.0, which represents a 1:1 ratio.

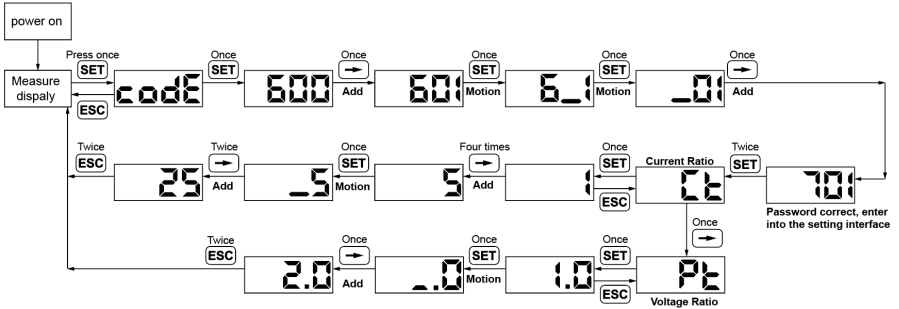

Figure 5-2 Set the Current Ratio and Voltage Ratio

### 5.3 Set Communication Address and Baud Rate

The default **communication address** is 1, and the default **baud rate** is 9600. Both parameters can be reconfigured if necessary to match the actual device address and the communication settings of the Ethernet card and inverter.

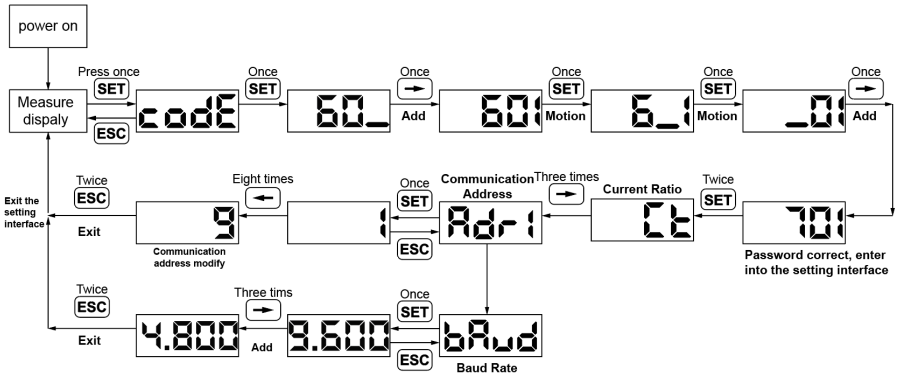

Figure 5-3 Set the Communication Address and Baud Rate

### 5.4 Set Communication Protocol

The default communication protocol is “n.1”, which represents “None parity, 1 stop bit, n.1”.

This parameter can be reconfigured if different protocol parameters are required for system integration.



## 6 Anti-Reflux Configuration

### CAUTION!



- The product can only be put into service after the installation and inspection is completed!
- Anti-reflux function cannot be used when a dispatch platform or monitoring instruments are in operation.
- Do not manually modify inverter dispatch values when anti-reflux is active, as this may cause dispatch inaccuracies. If this occurs, normal operation can only be restored after the next regulation cycle or Ethernet card reboot.
- Before enabling anti-reflux, ensure the multi anti-reflux function is enabled for all the inverters connected the Ethernet card.
- Ensure all inverters connected to the network interface have their multi-unit anti-reflux coordination function activated via remote communication.
- Anti-reflux requires communication reliability between Ethernet card and inverters with packet loss rate  $\leq 0.1\%$ . Higher loss rates will cause delayed control response.

### 6.1 Anti-Reflux Configuration via Mobile App

Anti-Reflux protection parameters can be configured via the mobile application or web interface of the MatriCloud platform. The following sections provide step-by-step guidance for parameter configuration through Mobile App. For anti-reflux configuration via Web interface, please see section 7.2 Anti-Reflux Configuration via Web Interface.

#### 6.1.1 Download App

Download Matricloud App of iOS version at Apple store or Android version in Google store or scan the QR code (Supports Android 7.0 and iOS 13.0 or later).



Figure 6-1 Download MatriCloud

## 6.1.2 Create a Site (Optional)

At the power site, you can use the App's remote connection mode to create a power site and connect it to the Ethernet card.

Skip these steps if the power site is created. Proceed directly to section 6.1.3 Enable Anti-Reflux of the Inverters and 6.1.4 Configure Anti-Reflux of the Gateway.

### 6.1.2.1 Registration on MatriCloud

The MatriCloud App supports three account type: Distributor, Installer, and Owner. Each type has specific roles in managing power stations:

- **Distributor:** A user who assists installers, owners, and end-users in creating, managing, and operating power stations.
- **Installer:** A user responsible for installing, commissioning, and maintaining power station devices.
- **Owner:** A station owner or end-user who monitors and manages their own power stations.

Follow these steps to sign up:

1. On the login interface, click **Sign up** to open the registration interface.

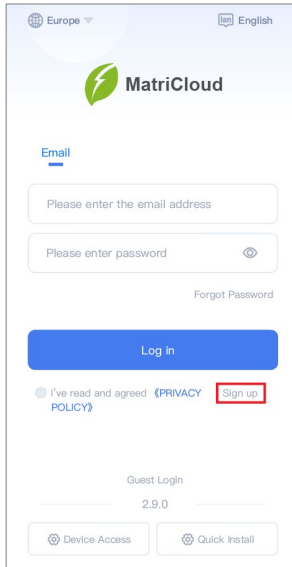

Figure 6-2 Click **Sign Up**

2. Check **Distributor**, **Installer**, or **Owner** to select your account type and load the signup form.

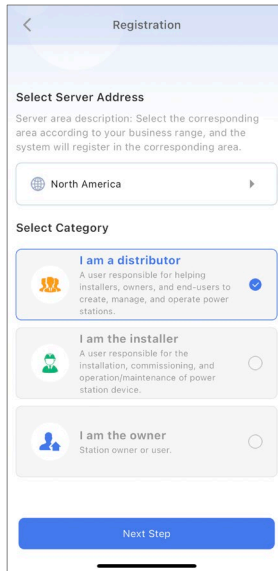

Figure 6-3 Select Account Type

3. Enter the required information. Then, Click **Submit** to complete your signup.
  - Company name (for Distributor or Installer): Your organization's name (e.g., "ChintPower").
  - Username (for Owner): Your chosen account name (e.g., "johnsmith").
  - Country(Region): The country or region where your organization or power station operates
  - Email address: Your email for account verification and login. (e.g., "user@chintpower.com").
  - Verification code: Click **Sent Code** after entering your email; then enter the 6-digit code sent to your inbox.
  - Password: Create your own password.
  - Verify Password: Re-enter your password to confirm it matches.
  - Access Code: Enter the organization code of your upper-level service; this lets your upper-level Distributor or Installer browse and manage your sites—contact them to obtain it.

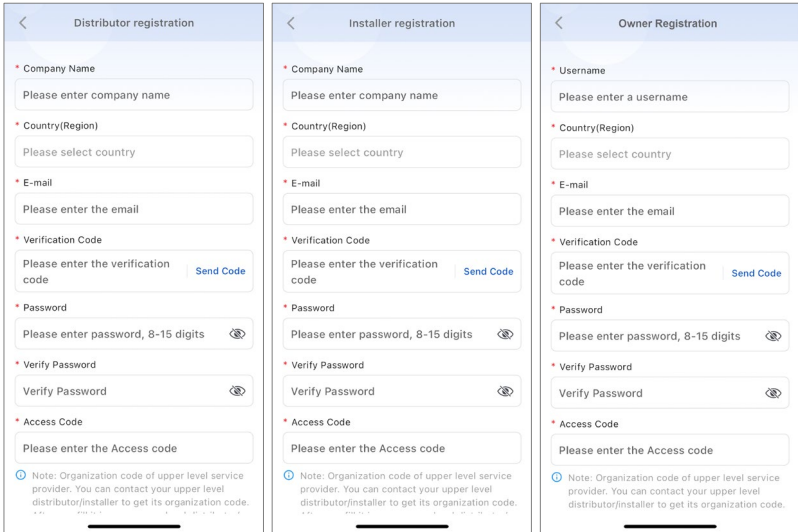

Figure 6-4 Sign Up Form

### 6.1.2.2 Create a Site

Follow the steps below to add a site:

1. On the Site page, click the + button to start creating a new site.

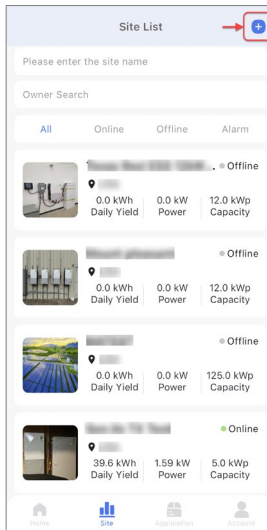

Figure 6-5 Create a Site

4. **Add Device:** Click **Scan to add device** to scan the barcode on the Ethernet card then click **Confirm** to proceed.

Note: If scanning fails, manually enter the controller's S/N in the provided field.

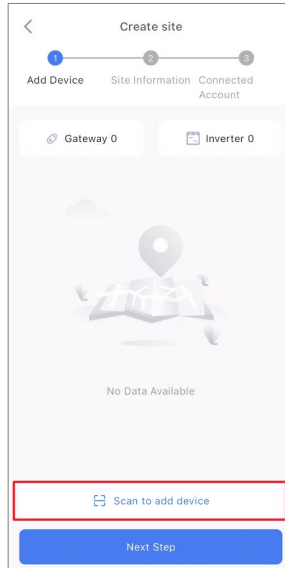

Figure 6-6 Add Gateway

2. **Site Information:** Enter all required information, then click **Next Step** to continue:
  - Site Name: Enter a name for the site (e.g., “SolarSite1”).
  - Site Address: Input the physical address of the site (e.g., “123 Solar St, USA”).
  - Region: Select the region where the site is located (e.g., “USA”) from the dropdown. This auto-fills Time Zone, Currency Unit, and Temp. Unit, but you can customize them.
  - Time Zone: Auto-filled based on Region (e.g., “UTC-5”); adjust using the dropdown if needed.
  - Site Type: Select the site category (e.g., “Residential ESS”) from the dropdown.
  - Grid-connected Type: Choose the grid connection type (e.g., “Distributed and All to the Grid”) from the dropdown.
  - Currency Unit: Auto-filled based on Region (e.g., “USD”); adjust using the dropdown if needed—also adjustable in account settings (see Section 7 Account).

- Temp. Unit: Auto-filled based on Region (e.g., “°C”); adjust using the dropdown if needed.
- Capacity (kWp): Enter the site’s capacity in kilowatt-peak (e.g., “10.0”).
- Benchmark Price (/kWh): Input the electricity price in currency per kWh (e.g., “0.15” for \$0.15/kWh).

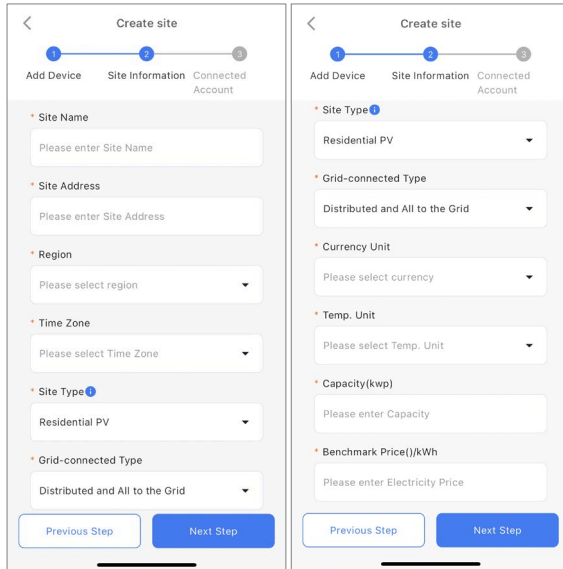

Figure 6-7 Fill in the Site Information

5. Connected Account: Assign a site to one or more users. Select the account or create a new account to link to the site:
  - Enter a username to search for an existing account, or use the company filter to narrow options. Then, click **Create** to finalize the site.

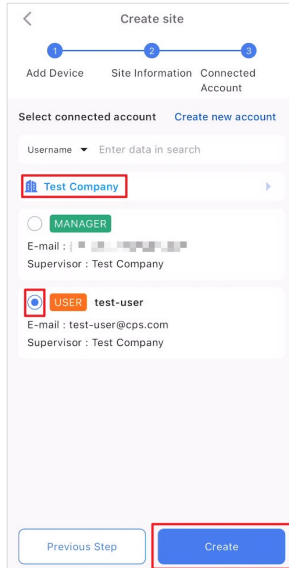

Figure 6-8 Account Selection

- Alternatively, create a new account by entering all necessary details step by step, then click **Create** to complete the site setup. Once created, the site will appear in the Site List.

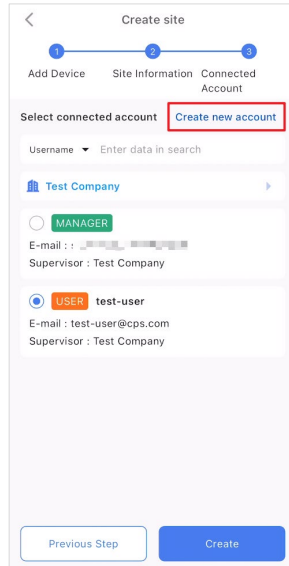

Figure 6-9 Create New Account

### 6.1.3 Enable Anti-Reflux of the Inverters

Enable anti-reflux of the inverters via App remote connection mode:

1. Go to site details page, click **Device** > **Gateway** to enter gateway details page.

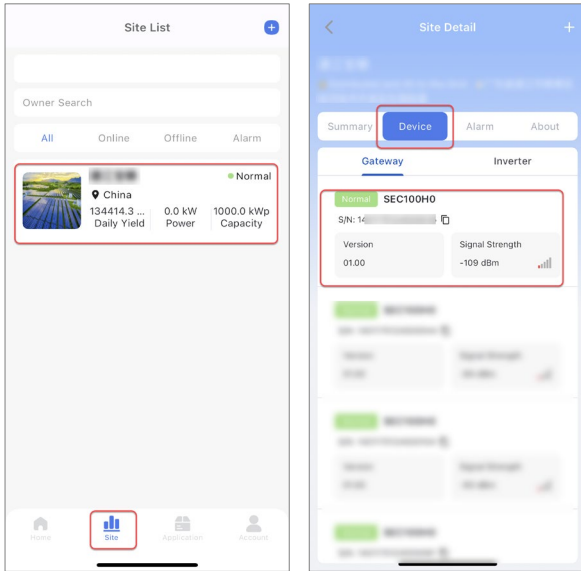

Figure 6-10 Click Gateway

2. Click **Devices** on the gateway details page. This page displays all the inverters connected to the Ethernet card. Click a device to enter the device details page.

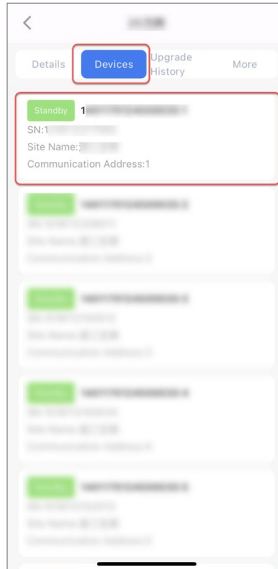

Figure 6-11 Click Device

3. On the device details page, click **More > Settings**.

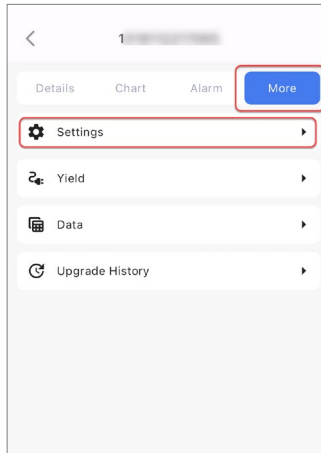

Figure 6-12 Click Setting

4. Search the register parameter: **AntiRefluxEn**. Configure this parameter to **Muti Anti-RefluxEn**.

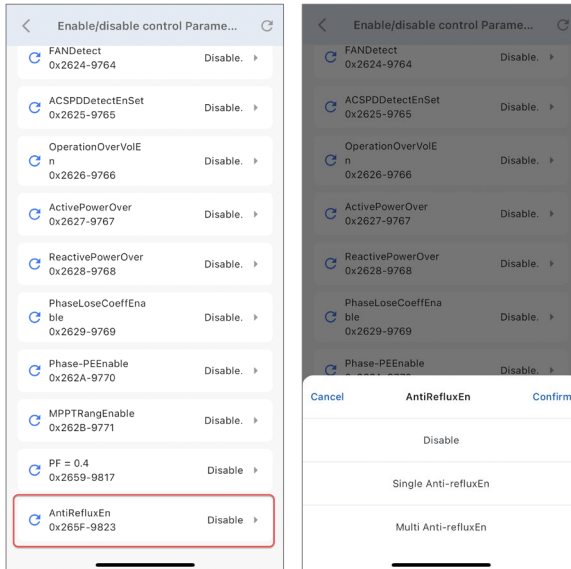

Figure 6-13 Enable Anti-reflux for Inverter

5. Repeat steps 3 and 4 to enable anti-reflux for all devices connected to this gateway as needed.

## 6.1.4 Configure Anti-Reflux of the Gateway

Use the App local connection mode to configure the anti-reflux parameters of gateway (communication module).

### 6.1.4.1 Connect to Inverter

1. Enable the Bluetooth function of your mobile device, then open the MatriCloud App. (No account or password is needed)
2. Click **Device Access**.

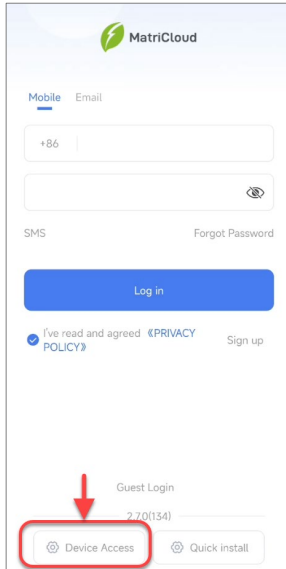

Figure 6-14 Click Device Access

3. Click **Bluetooth Connect**.

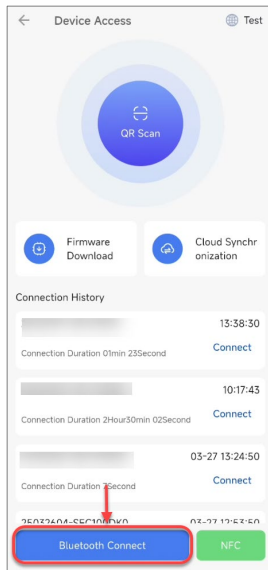

Figure 6-15 Click Bluetooth connect

- Click the inverter number (Last 8 numbers of the SN) to access main screen.

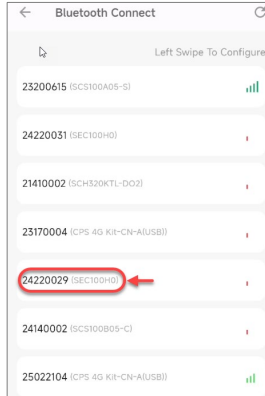

Figure 6-16 Select a Bluetooth to connect

- Click the device settings icon in the top-right corner of the main interface.

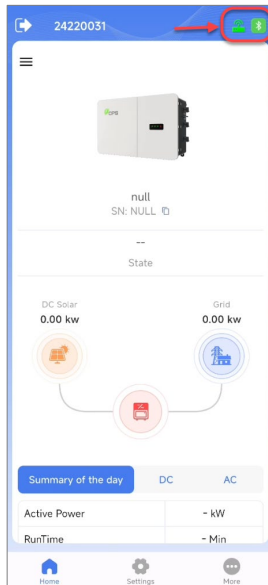

Figure 6-17 Click terminal setting

- Click **Basic Configuration**. (If password needed, enter 1111).

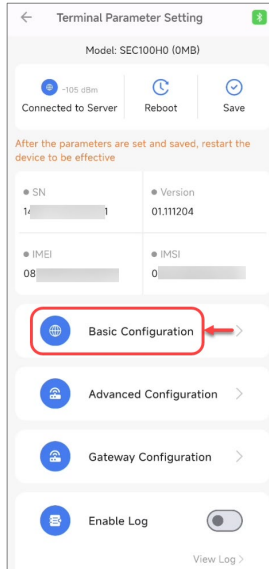

Figure 6-18 Click Basic Configuration

7. Click Modify to modify the protocol.

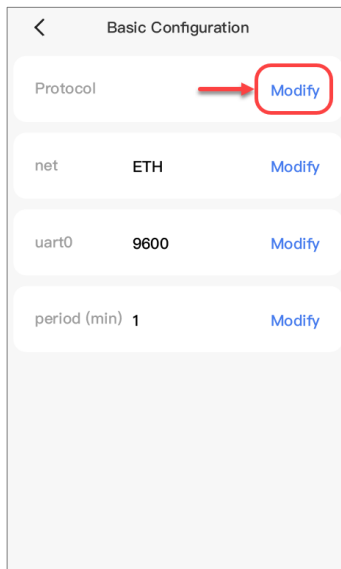

Figure 6-19 Modify Protocol

- Set ID Address according to the inverter installation quantity. Then, click **Save**.

**Note:** Please select the appropriate inverter protocol. If uncertain, contact technical support.

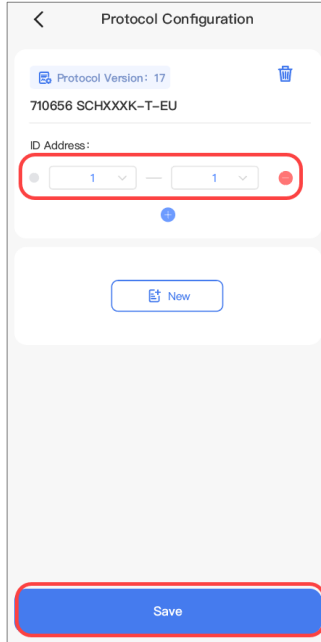

Figure 6-20 Set ID Address

#### 6.1.4.2 Configure Anti-Reflux Parameters

- Back to the terminal parameters setting interface. Click **Gateway Configuration** of the terminal parameter setting screen.

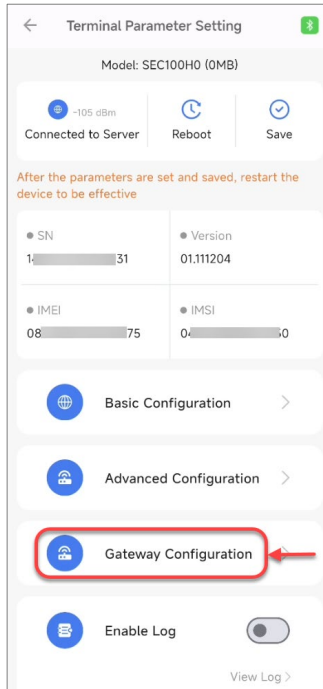

Figure 6-21 Click gateway configuration

2. Click **Anti-Reflux Power Flow Configuration**.

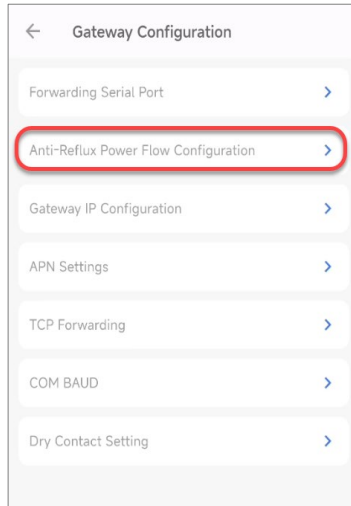

Figure 6-22 Click anti-reflux power flow configuration

3. Enable the anti-reflux feature, and configure the parameters.

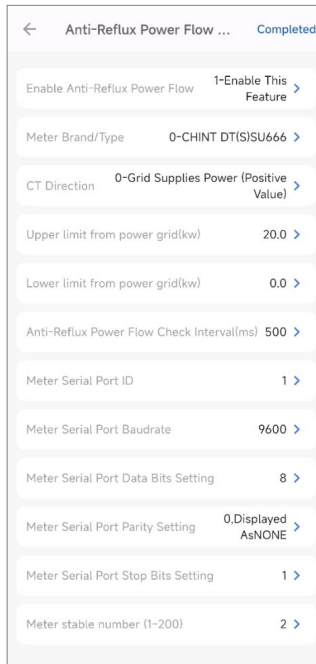

Figure 6-23 Configure anti-reflux parameters

## Key Parameter Description

Parameter	Description
Enable Anti-Reflux Power Flow	Enable or disable the anti-reflux feature
Meter Brand / Type	Select the meter type or brand inside the controller
CT Direction	Set the CT direction to point toward the inverter and load direction.
Upper limit from power grid	Limits the maximum power the system can import from the grid. When anti-reflux is enabled, the system ensures grid import does not exceed this value. This limit must be greater than the lower limit.
Lower Limit from Power Grid	Limits the minimum power the system can import from the grid. This value can be negative, which may cause backflow (power fed into the grid). It is recommended to set this value to 0 and ensure the upper limit is greater than the lower limit. <b>Note:</b> The larger the inverter capacity, the greater the difference between the upper and lower limits should be.
Anti-Reflux Power Flow Check Interval	Indicates the time interval between two consecutive anti-reflux condition checks. After each anti-reflux detection is completed, the system will wait this amount of time before initiating the next check. The minimum value is 500ms.
Meter stable number	This parameter is used to prevent frequent adjustments caused by fluctuations in meter data when there are significant current changes. It serves as a stability judgment threshold. A larger value, especially with greater current variations, can increase the error in meter data, resulting in slower anti-reflux control response. (Recommended value: 2)

Table 6-1 Key Anti-Reflux Parameters Description

4. Configure Gateway IP: Click **Gateway IP Configuration** to configure the IP. When using a fixed IP address, disable the DHCP, then manually configure the IP address, subnet mask, default gateway and DNS server. With DHCP enabled, the system automatically configures all network settings including these parameters.

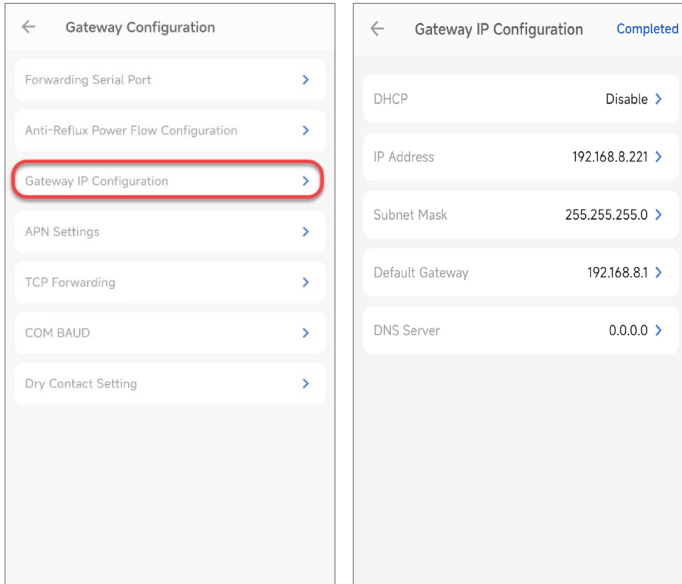

Figure 6-24 Configure gateway IP

5. After completing the parameter settings, return to **Terminal Parameter Setting**. Click **Save** to save the changes, then click **Reboot** to restart the Ethernet card.

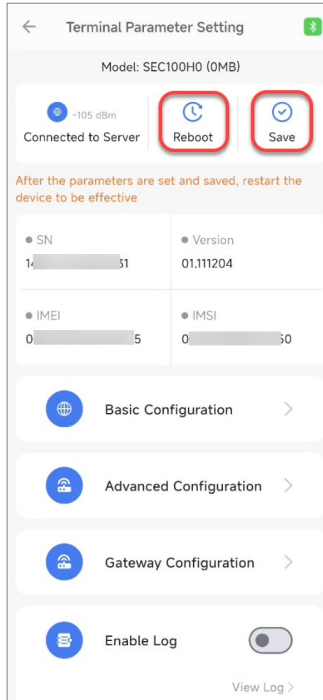

Figure 6-25 save and reboot

### 6.1.5 View the Energy Flow Diagram and Meter Data

Use the App remote connection mode to view the energy flow diagram and meter data. Local mode does not support this functionality.

- View the energy flow Diagram: When using Ethernet card for network communication, view the energy flow diagram on the site details page to visualize PV generation and consumption. Note: Load values remain fixed at 0 when no meter is connected.

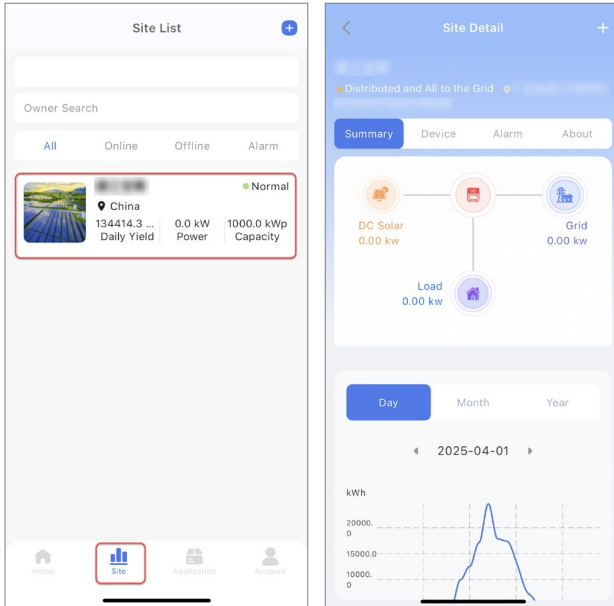

Figure 6-26 view energy flow diagram

- View the meter data: Go to site details page, click **Device** > **Gateway** to enter gateway details page. Then, click **More** > **Electric Meter** to view the meter data.

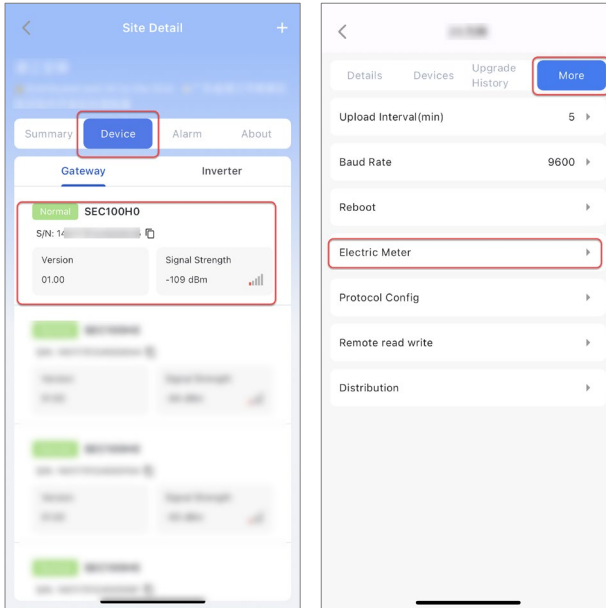

Figure 6-27 View Meter Data

## 6.2 Anti-Reflux Configuration via Web Interface

Follow these steps to configure the anti-reflux parameters via web interface.

### 6.2.1 Log into Web platform

1. Log in to the MatriCloud platform using registered account and password.
  - For Asia-Pacific: Go to <https://icloud.chintpower.com>.
  - For Europe: Go to <https://eu.chintpower.com>.
  - For North American: Go to <https://icloud.chintpowersystems.com>.





### 6.2.3 Configure Anti-Reflux of the Ethernet Card

1. Back to the gateway details page, go to **Setting** > **Anti-Reflux**. Enable the anti-reflux feature of the gateway, configure the parameters, then click **Submit** to save the settings.

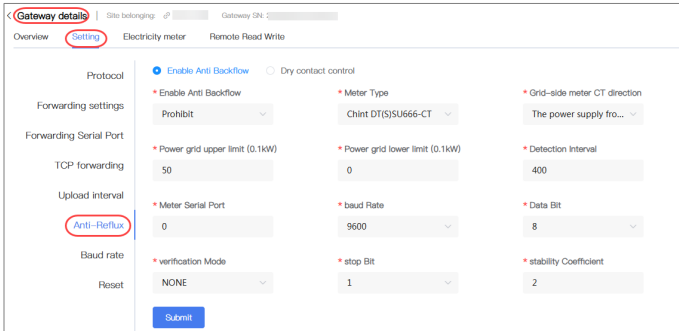

Figure 6-33 Configure anti-reflux parameter for Gateway (Communication Module)

2. Go to **Setting** > **Reset**, click **Reset** to restart the Ethernet card.

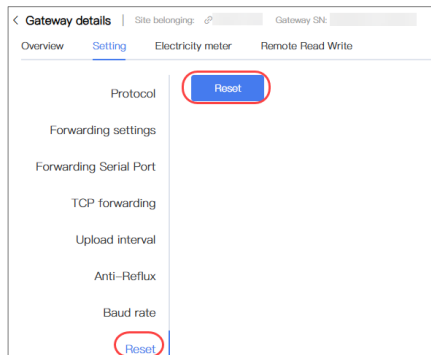

Figure 6-34 Restart Gateway (Communication Module)

### 6.2.4 View Energy Flow Diagram and Meter Data

- View the energy flow chart: When using Ethernet card for network communication, view the energy flow diagram on the site details page to visualize PV generation and consumption. Note: Load values remain fixed at 0 when no meter is connected.

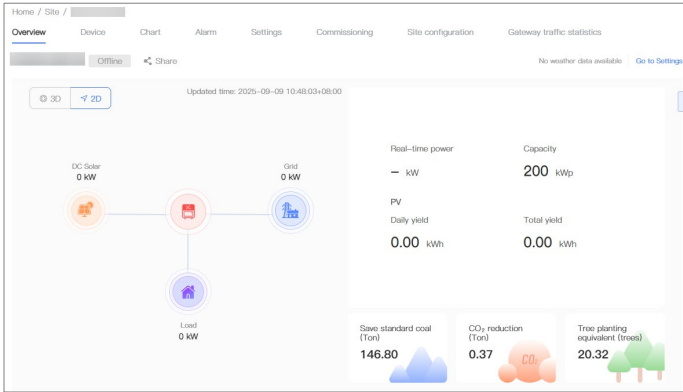
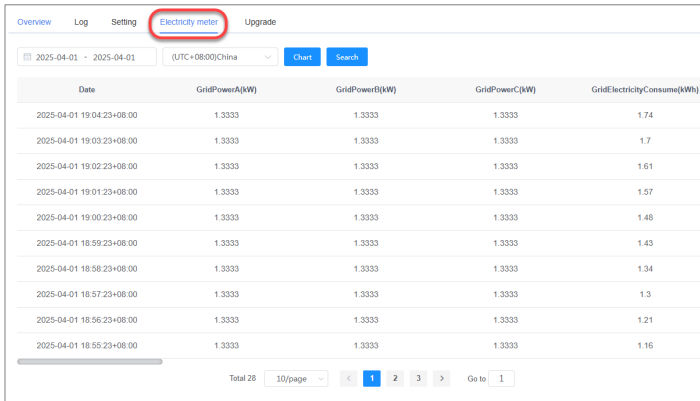

Figure 6-35 View Energy flow diagram

- View the meter data: Go to **Gateway details** page, click **Electricity meter** to view the data.



The screenshot shows the 'Electricity meter' data table. The table has five columns: Date, GridPowerA(kW), GridPowerB(kW), GridPowerC(kW), and GridElectricityConsume(kWh). The data is filtered for the date 2025-04-01. The table shows 10 rows of data, all with a GridPower value of 1.3333 kW and a GridElectricityConsume value ranging from 1.16 to 1.74 kWh. The 'Electricity meter' tab is highlighted with a red circle in the original image.

Date	GridPowerA(kW)	GridPowerB(kW)	GridPowerC(kW)	GridElectricityConsume(kWh)
2025-04-01 19:04:23+08:00	1.3333	1.3333	1.3333	1.74
2025-04-01 19:03:23+08:00	1.3333	1.3333	1.3333	1.7
2025-04-01 19:02:23+08:00	1.3333	1.3333	1.3333	1.61
2025-04-01 19:01:23+08:00	1.3333	1.3333	1.3333	1.57
2025-04-01 19:00:23+08:00	1.3333	1.3333	1.3333	1.48
2025-04-01 18:59:23+08:00	1.3333	1.3333	1.3333	1.43
2025-04-01 18:58:23+08:00	1.3333	1.3333	1.3333	1.34
2025-04-01 18:57:23+08:00	1.3333	1.3333	1.3333	1.3
2025-04-01 18:56:23+08:00	1.3333	1.3333	1.3333	1.21
2025-04-01 18:55:23+08:00	1.3333	1.3333	1.3333	1.16

Figure 6-36 View meter data

## 7 Maintenance

### IMPORTANT!



Only qualified and authorized personnel may perform maintenance and other operations on the Smart Communication Box.

### 7.1 Regular Maintenance

To keep the device working normally for a long time, it is necessary to check its working status regularly. Regular maintenance items are as follows:

- Ensure that no strong electromagnetic interference devices are placed near the controller.
- Ensure that no heat sources are placed near the controller.
- Regularly wipe away dirt.
- Periodically check for signs of loose cable connections.

### 7.2 Troubleshooting

This section provides a quick-reference list of common fault symptoms, their potential causes, and recommended solutions for the anti-reflux function. The table below outlines typical fault scenarios, their observable symptoms, and recommended corrective actions.

If a problem occurs, please refer to this table as the first step in identifying the potential cause and implementing the corresponding solution. For issues not covered in this guide or if the proposed solution does not resolve the problem, please contact our technical support team.

Fault Description	Symptoms	Possible Cause or Solution
Anti-reflux function failure	The meter display does not match the expected anti-reflux effect.	<ol style="list-style-type: none"> <li>1. Incorrect Current Transformer (CT) wiring.</li> <li>2. The controller is not powered on or running.</li> <li>3. The multi-unit anti-reflux function is not enabled on the inverter(s).</li> <li>4. The remote control function is not activated on the inverter(s).</li> </ol>
Abnormal meter power reading	The power value displayed on the	<ol style="list-style-type: none"> <li>1. Incorrect Current CT wiring.</li> </ol>

	meter significantly differs from the actual power.	2. Incorrect CT ratio setting configured in the meter.
Single Inverter Not Generating Power	The inverter's output power remains at zero.	1. Incorrect communication parameter settings on the inverter. 2. Inverter communication cable is disconnected.
All Inverters in group are not generating power	The meter reading is consistent with the load power; no reverse power flow.	1. Communication loss with the meter. 2. Communication failure between the device and all inverters.
Intermittent inverter shutdown	The meter reading fluctuates significantly under stable load conditions.	Unstable communication signal with the inverter (intermittent or interfered).
Poor anti-Reflux control accuracy	The meter reading deviates from the expected control target.	Improper parameter settings for the anti-reflux function. Requires recalibration.

Table 7-1 Troubleshooting Quick Reference List

## 8 Technical Data

<b>Model</b>	<b>SAU100J0</b>
<b>Communication</b>	
Max. Inverters Connected	10
RS485 Interface	1
Ethernet Interface	1 × RJ45, 10 / 100 Mbps
<b>Configuration</b>	
Datalogger	Smart Ethernet Card × 1
Meter	DTSU666~1.5A(6A) +3CTs
Compatible Current Transformer*1	nA:5A
Nominal Voltage	230 / 400 Vac, 50 / 60 Hz
<b>Mechanical</b>	
Dimensions (W x H x D)	400 × 426 × 147.8 mm
Weight	7 kg
Installation Method	Wall mounting / Bracket mounting
<b>Environment</b>	
Operating Temperature Range	-30℃ ~ + 60℃
Storage Temperature Range	-40℃ ~ + 85℃
Working Humidity	5%-95% (No Condensation)
Max. Operating Altitude	2000 m
Ingress Protection Rating	IP66

Table 8-1 Technical Data

Note:

\*1 Standard configuration is 300A: 5A, can use customized current transformers. The secondary nominal rms current must be 5A.

## Contact Information

Please do not hesitate to contact us if you have any questions regarding this product. We are glad to provide the best service for you.

Shanghai Chint Power System Co., Ltd.

Headquarters: No. 5999, Guangfulin Road, Songjiang District, Shanghai, P. R. China

Switchboard: +86-021-37791222

Fax: +86-021-37791222-6001

Website: [www.chintpower.com](http://www.chintpower.com)

Service Hotline: 021-37791222-6300

Email: [service.cps@chint.com](mailto:service.cps@chint.com)