

1. Product Overview

1.1 Appearance and Dimension

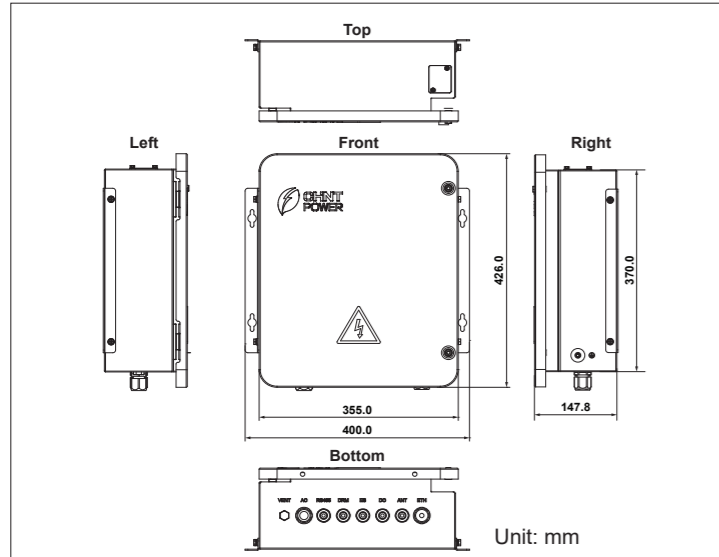

1.2 Bottom Connection

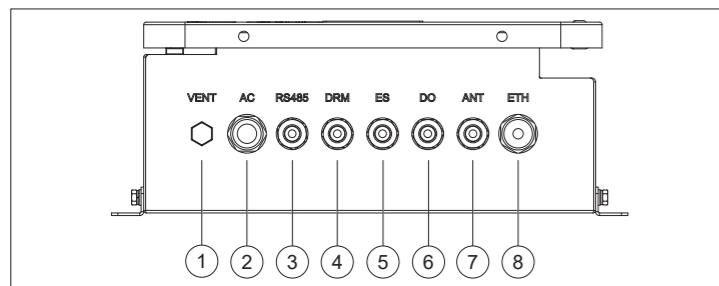

No.	Terminal	Usage
1	Vent	Vent vale for balancing the pressure difference
2	AC	AC cable outlet
3	RS485	RS485 cable outlet
4	DRM	Demand Response Management (DRM) cable outlet
5	ES	Emergency Stop (ES) cable outlet
6	DO	Digital Output (DO) cable outlet
7	ANT	Feeder line outlet for Bluetooth suction cup antenna
8	ETH	Ethernet cable outlet

1.3 Internal Structure

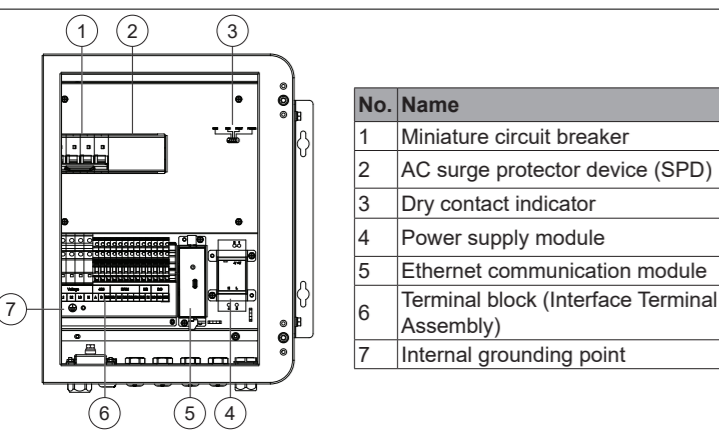

2. Mechanical Installation

2.1 Delivery List

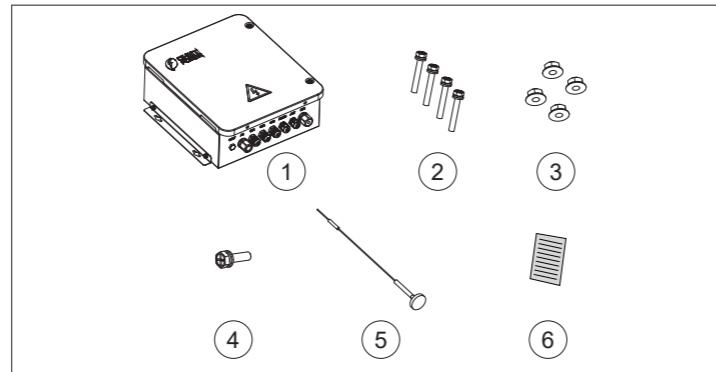

No.	Name	Type	Quantity
1	Smart Power controller	SAU100N2-DIO-EU	1
2	Combination ccrew	M6 x 42	4
3	Flange nut	M6	4
4	Combination screw	M5 x 12	1
5	Suction cup antenna	YE0016AA	1
6	Quick installation guide	N/A	1

2.2 Recommended Clearances

During planning and installing the controller, appropriate clearances ar indicated below shall be reserved to facilitate access, maintenance, and to prevent cable strain or physical damage.

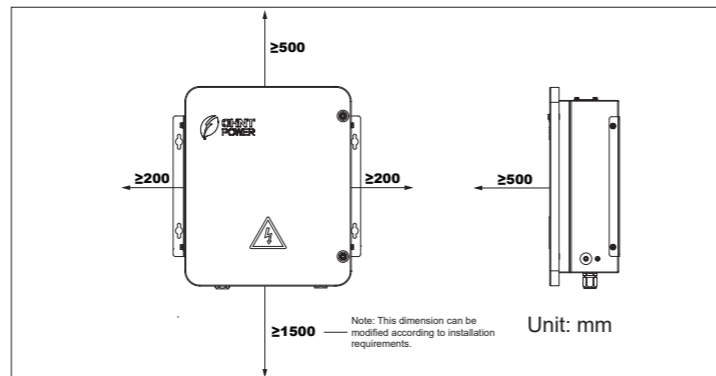

2.3 Installation Environment Requirements

It is recommended to install controller under a shelter to avoid direct sunlight, rain and snow accumulation, to prevent from increasing controller failures or reducing its service life.

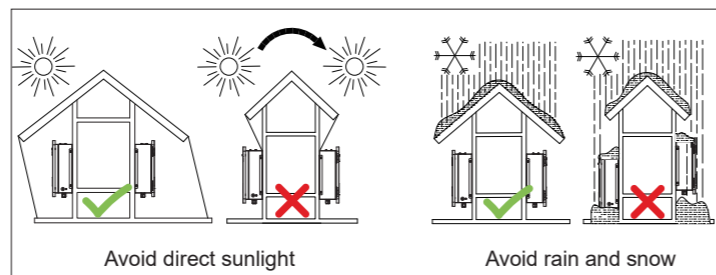

2.4 Installation Procedures

1. Use a marker to mark drilling points on the support structure (wall, steel rack, etc.) according to the mouting dimensions in the figure below.

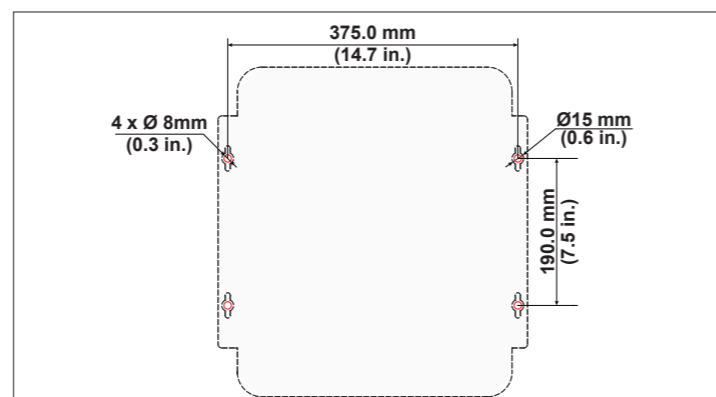

2. Drill four holes at the marked positions.

Tool: Electric drill with Ø8.0 mm drill bit.

3. Align the four mounting holes on the controller cabinet with the four holes on the support structure. Secure the controller using the M6x42 screws and M6 flange nuts, then tighten them firmly.

Tool: 10 mm hex socket wrench. Torque: 8.3 N·m - 10 N·m.

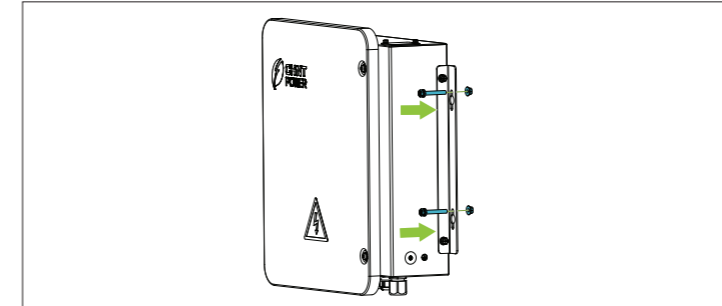

3. Electrical Connection



Before wiring, switch off the miniature circuit breaker inside the controller and ensure that all upstream and downstream circuits connected to the controller are completely de-energized.

3.1 Recommended Tools and Torques

Tool	Usage	Torque Value
5mm hex socket wrench	Open front cover	N/A
	Secure front cover	3 N·m
PH2 Phillips screwdriver	Fix internal grounding terminal	1.6 N·m
	Fix AC terminal	1.3 N·m
No.10 socekt wrench	Fix external grounding terminal	5.9 N·m
#1 flathead screwdriver	Fix RS485, DI, ES, DO terminal	0.6 N·m
Wire stripper	Remove the insulation layer from cable	N/A
Diagonal plier	Cut cable	N/A
Crimping plier	Crimp the terminal and cable	N/A

3.2 Cable Specification

Cable	Type	Cable Outer Diameter	Cross-Sectional Area
AC	Outdoor four-core copper wire	6mm - 15mm	• L1/L2/L3/N: 4mm ² -10mm ²
	Outdoor single-core copper wire	4mm - 6mm	• PE: 1mm ² - 6mm ²
Grounding	Outdoor copper-core wire	6.4mm - 7.3mm	6mm ² - 10mm ²
RS485	Double-layer insulated cable	4.5mm - 6mm	3x0.2mm ² - 0.75mm ²
DRM	Double-layer insulated cable	7mm - 10mm	5x0.2mm ² - 0.75mm ²
ES	Double-layer insulated cable	4.5mm - 6mm	2x0.2mm ² - 0.75mm ²
DO	Double-layer insulated cable	4.5mm - 6mm	3x0.2mm ² - 0.75mm ²

3.3 Open Front Cover

1. Loosen the two screws to open the front cover.

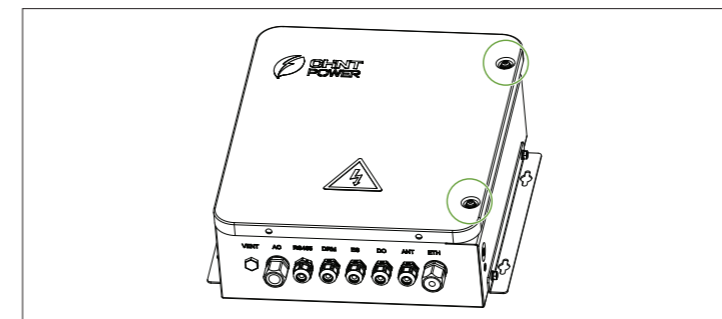

2. Use the support rod to hold the front cover, ensuring it is firmly snapped into the slot.

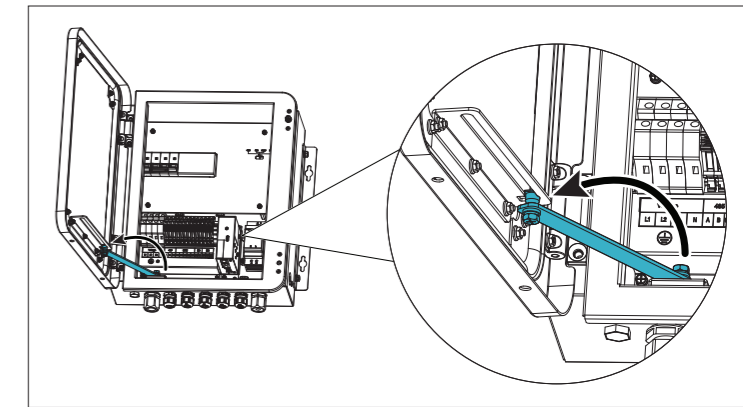

3.2 Grounding (Protection Earthing)

The grounding cable must be connected using at least one of the following methods:

- Internal Grounding: Connect grounding cable to the grounding hole located at the lower-left inside the controller using the pre-installed M4x10 screw.

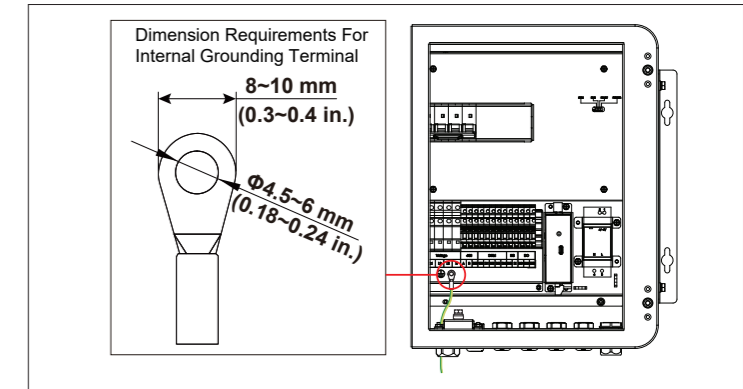

- External Grounding: Connect grounding cable to the grounding hole is located in the lower-right corner outside the controller using the M5x12 screw.

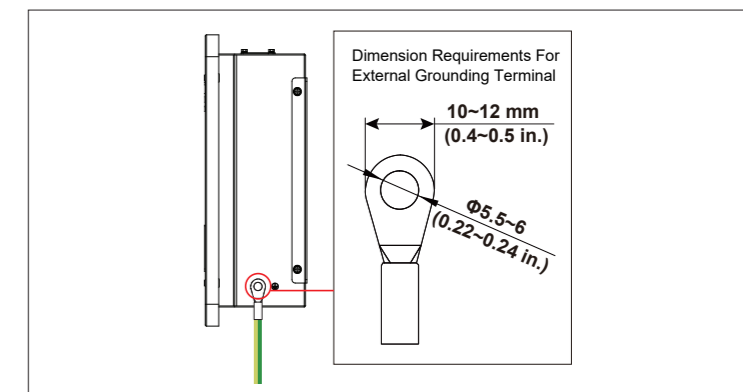

Note: After wiring, the external PE point needs to be coated with glue or paint. Other sizes of grounding cables that meet local standards and safety regulations can also be used for grounding connections. But CHINT shall not be liable for any damage caused.

3.3 AC Cable Wiring

1. Strip the jacket and insulation layer of the AC cable to the appropriate length, exposing the conductors. Insert the conductors into the tube terminals until contacting the terminal's barrel end, align the cable insulation edge with the terminal's crimping wings, then crimp firmly to secure the connection.

Note: The tube terminals are customer-supplied, compatible model is E6010.

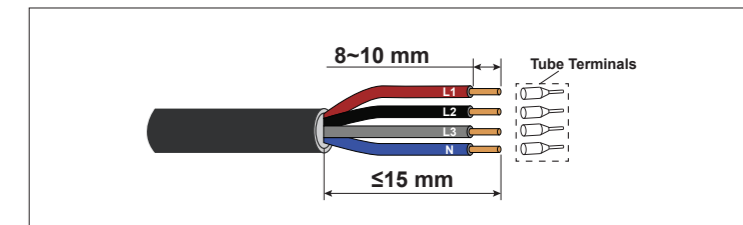

2. Loosen the locking nut of AC cable gland, and thread the crimped AC cable through the AC outlet. Insert the phase lines (L1/L2/L3) and neutral line (N) into the corresponding terminals. Tighten the terminal screws. Finally, re-tighten the gland nut.

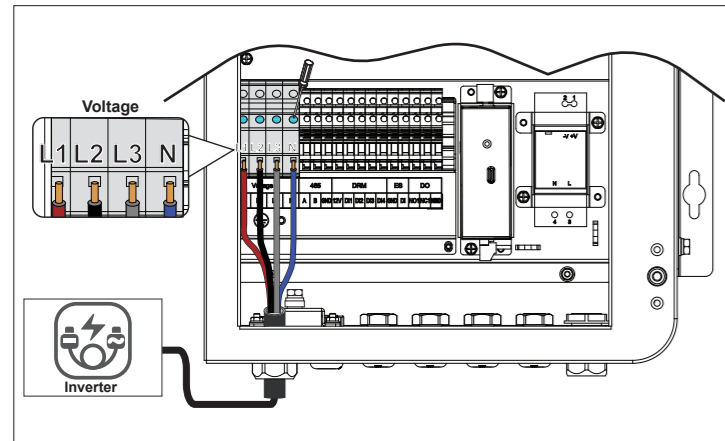

3.4 RS485 Cable Wiring

1. Strip the jacket and insulation layer of the RS485 cable to the appropriate length, exposing the conductors. Insert the conductors into the tube terminals until contacting the terminal's barrel end, align the cable insulation edge with the terminal's crimping wings, then crimp firmly to secure the connection.

Note: The tube terminals are customer-supplied, compatible models are E0206~E0506.

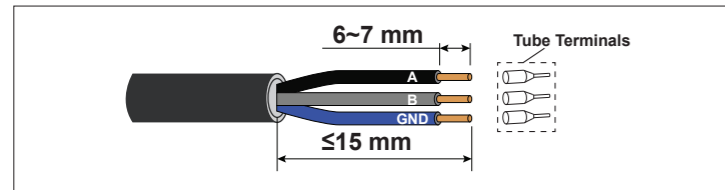

2. Loosen the locking nut of the RS485 gland, and thread the crimped RS485 cable through the RS485 cable outlet. Insert the RS485 wires into the corresponding terminals. Tighten the terminal screws. Finally, re-tighten the gland nuts.

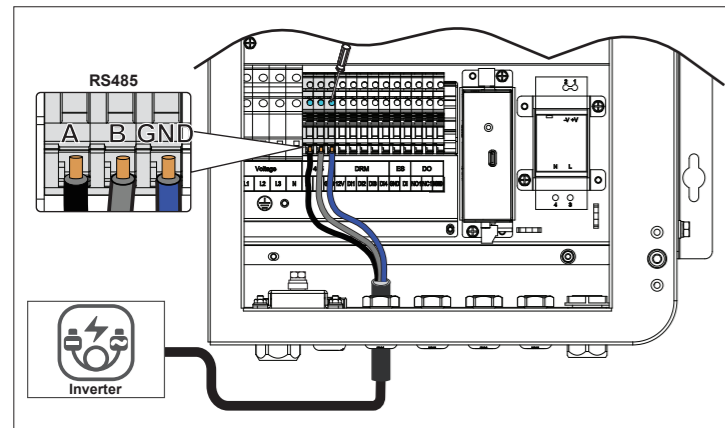

3.5 DRM Cable Wiring

Refer to 3.4 for wire stripping and crimping. Loosen the locking nut of the DRM gland, and thread the crimped DRM cable through the DRM cable outlet. Insert the DRM wires into the corresponding terminals. Tighten the terminal screws. Finally, re-tighten the gland nut.

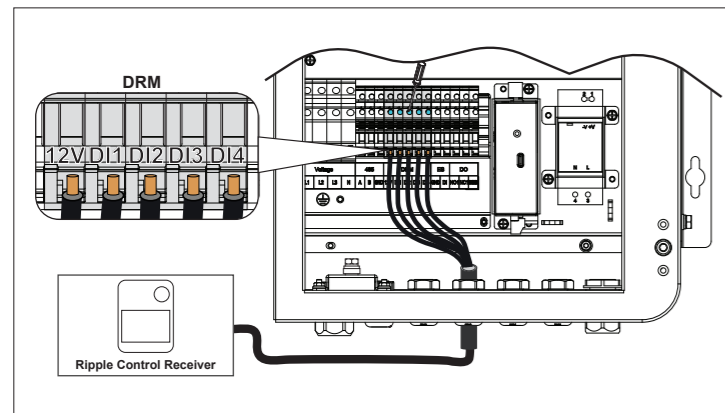

3.5 ES Cable Wiring

Refer to 3.4 for wire stripping and crimping. Loosen the locking nut of the ES gland, and thread the crimped ES cable through the ES cable outlet. Insert the ES wires into the corresponding terminals. Tighten the terminal screws. Finally, re-tighten the gland nut.

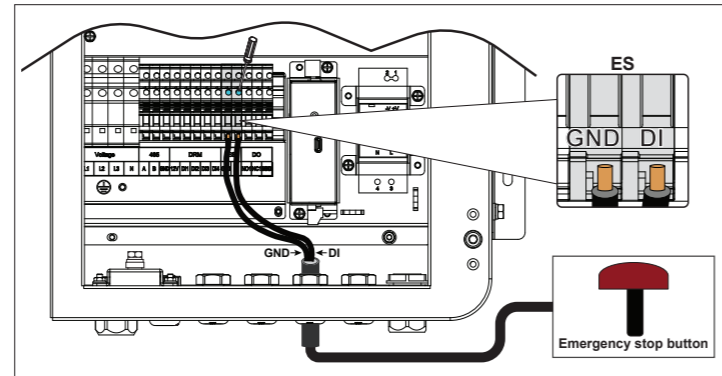

3.6 DO Cable Wiring

Refer to 3.4 for wire stripping and crimping. Loosen the locking nut of the DO gland, and thread the crimped DO cable through the DO cable outlet. Insert the DO wires into the corresponding terminals. Tighten the terminal screws. Finally, re-tighten the gland nut.

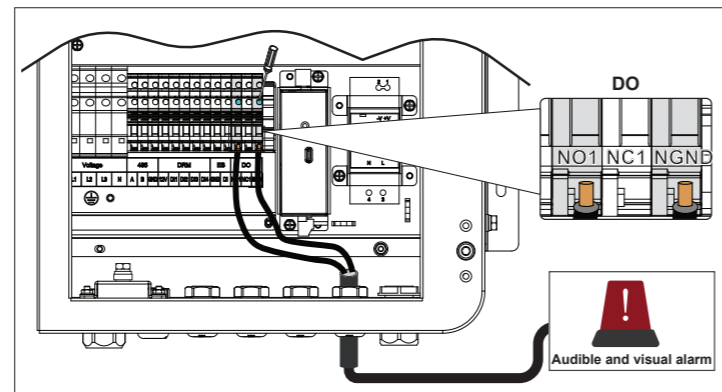

3.7 Install Suction Cup Antenna

The Ethernet communication module inside the controller supports both wired (via Ethernet cable) and wireless (Bluetooth) communication. To enable Bluetooth operation:

1. Thread the Bluetooth cable through the ANT hole, then use hand to secure the mounting nut to the module's Bluetooth antenna terminal.

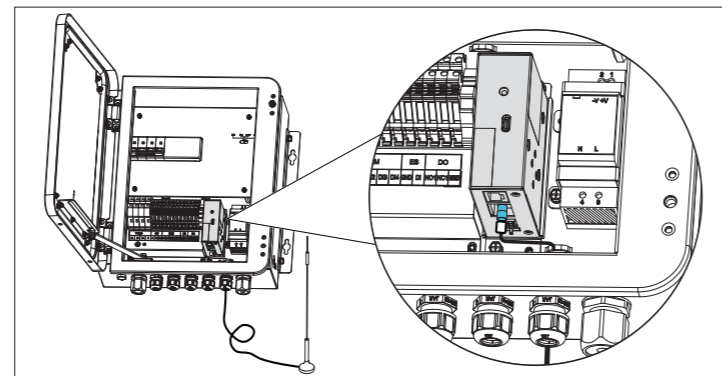

2. Attach the antenna's magnetic base to the surface on the controller top.

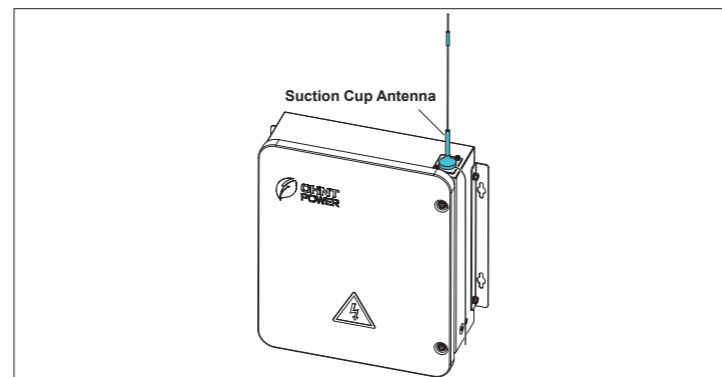

After completing all wiring steps, secure the front cover by tightening all screws to prevent water ingress. Ensure that all waterproof terminals are firmly fastened, and seal any gaps at the bottom of the terminals with firestop putty.

4. Dry Contact Indicator

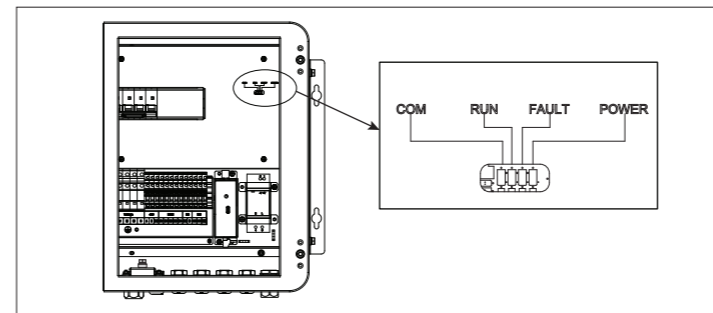

Indicator	Name	Status	Indication
COM	Communication indicator	On (Green)	No communication
		Off	
		Flash	
RUN	Operation indicator	On	Software is running in BOOT
		Flash (Green, 1 s interval)	Software is running in App
		Off	Software is not running
FAULT	Reserved		
POWER	Power indicator	On (Green)	Controller is powered
		Off	Controller is not powered

5. App Configuration

Dry contact parameters are configurable through the MatriCloud platform's mobile application or web interface. The section covers basic App configuration; for advanced options or web setup, refer to the User Manual. Switch on the circuit inside the controller. Download MatriCloud the App Store or Google Play, or scan the QR code. (Supports Android 7.0 and iOS 13.0 or later)



5.2 Basic Configuration

Enable the Bluetooth on your mobile device, then launch the MatriCloud App. Configure the basic settings of terminal follows:

1. Click **Device Access**. (No account and password required)
2. Click **Bluetooth Connect**.
3. On the Bluetooth connection interface, locate the corresponding device using the last 8 digits of the Ethernet communication card's serial number. Then, swipe left to open the terminal settings interface.
4. Click **Basic Configuration**. (If password needed, enter "1111")
5. Configure the inverter protocol. Then, click **Save**.
6. Configure the network connection mode.

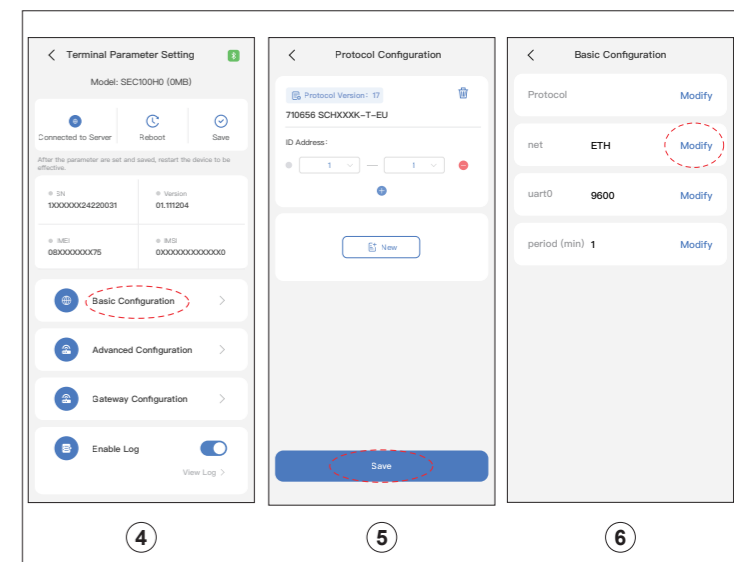
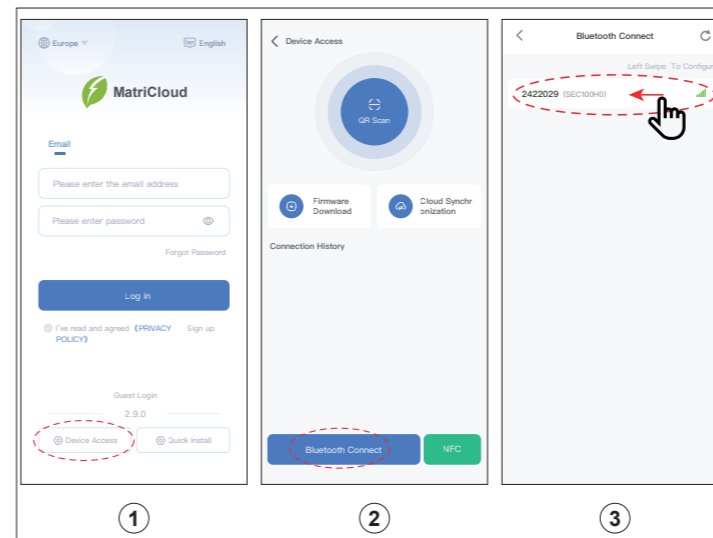

5.2 Gateway Configuration

1. Go to the **Terminal Parameter Setting** interface, and click **Gateway Configuration** to open the gateway settings interface.
2. Click the **Forwarding Serial Port** tab to open the configuration interface, configure the communication port number, baud rate, checksum/CRC scheme, stop bit, and protocol type. Then, click **Completed**.
3. Click the **Anti-Reflex Power Flow Configuration** tab, disable the anti-reflux power flow function. Then, click **Completed**.
4. Click the **COM BAUD** tab, configure the COM and baud rate. Then, click **Confirm**.
5. Click the **Dry Contact Setting** tab, enable this function. Then, click **Confirm**.
6. Return to the **Terminal Parameter Setting** interface. Click **Save**, then click **Reboot** afterwards. After the network card restarts, check the COM indicator. Flashing indicates successful configuration and normal communication with the dry contact board.

