

# **CPS ES-125kW/261kWh-EU Liquid-cooled Commercial and Industrial Integrated Cabinet User Manual**



Shanghai Chint Power Systems Co., Ltd.

Rev.: V1.2

Date: December 16, 2025 Doc No.:9.0020.1020A0



# Table of Contents

<b>1</b>	<b>Preface.....</b>	<b>9</b>
<b>2</b>	<b>Safety Information Instructions .....</b>	<b>11</b>
2.1	Warning Content in this Manual.....	11
2.2	Warning Labels on the Equipment.....	14
2.3	Safety Requirements for the Owner .....	15
2.4	Lockout/Tagout Guidance .....	16
2.4.1	Danger .....	16
2.4.2	Warning .....	16
2.4.3	General Warning .....	17
2.5	Terms and Definitions .....	19
<b>3</b>	<b>System Introduction.....</b>	<b>22</b>
3.1	System Applications.....	22
3.2	System Functions .....	22
3.3	System Description and Parameters .....	24
3.3.1	System Description Scope .....	24
3.3.2	System Annotation .....	24
3.3.3	System Detailed Parameters.....	25
3.4	System Architecture Diagram .....	29
3.4.1	Electrical Architecture Diagram .....	29
3.4.2	Communication Architecture Diagram.....	29
3.4.3	System Equipment Layout Diagram.....	30

---

3.4.4	System Incoming and Outgoing Lines .....	35
3.4.5	Nameplate .....	38
3.5	Battery Management System .....	40
3.6	Power Conversion System.....	43
3.7	Battery System.....	43
3.7.1	Battery PACK.....	45
3.7.2	High Voltage Box.....	46
3.8	Local Energy Management System.....	50
3.8.1	LEMS Control System Diagram .....	51
3.8.2	System Functions .....	52
3.8.3	Communication Connection .....	53
3.9	Grounding Wire.....	54
3.10	Connection Cable between Battery PACKs.....	56
<b>4</b>	<b>Equipment Receiving and Installation .....</b>	<b>57</b>
4.1	Personnel Requirements .....	57
4.2	Personal Protective Equipment and Tools .....	57
4.3	Transportation and Delivery.....	58
4.3.1	Transportation Conditions .....	58
4.3.2	Hoisting.....	58
4.4	Installation Requirements .....	59
4.5	System Unpacking Inspection .....	59
4.5.1	Precautions.....	59
4.5.2	Safety Inspection.....	60

---

4.5.3	Equipment Status Check.....	61
4.5.4	Inspection Record .....	61
<b>5</b>	<b>Emergency Handling Procedure.....</b>	<b>62</b>
5.1	First Aid Measures .....	62
5.2	Fire Risk Assessment .....	62
5.2.1	General Principles .....	62
5.2.2	Management System .....	63
5.2.3	Overall Summary.....	63
5.2.4	Classification of Fire Hazards.....	64
5.2.5	Fire Risk Deduction .....	65
5.2.6	Fire Safety System .....	68
5.2.7	Identify Fire Hazards .....	69
5.2.8	Flood and Water Disaster Risk Response .....	69
5.3	Emergency Measures .....	69
5.3.1	Emergency Measures Plan .....	69
<b>6</b>	<b>System Power On/Off Operation Procedures.....</b>	<b>71</b>
6.1	Operational Procedures for C&I Integrated Cabinet.....	71
6.1.1	Pre-power-on Inspection .....	71
6.1.2	Power-on Operation .....	71
6.1.3	Power-off Operation .....	73
6.2	BMS System Operation Procedures.....	75
6.2.1	BMS System Architecture.....	75
6.2.2	System Configuration Preparation .....	76
6.2.3	BMS System Configuration .....	76

---

6.2.4	ESMU Configuration.....	78
6.2.5	Network Port Configuration .....	80
6.2.6	Typical Protection Strategy.....	80
6.3	PCS Operation Procedures .....	80
6.4	LEMS Operation Procedures.....	80
<b>7</b>	<b>Troubleshooting .....</b>	<b>81</b>
<b>8</b>	<b>Performance Maintenance.....</b>	<b>82</b>
<b>9</b>	<b>Quality Assurance .....</b>	<b>83</b>
9.1	Liability Exemption .....	83
9.2	Quality Terms (Warranty Terms) .....	84
<b>Annex 1</b>	<b>Safety Training Records.....</b>	<b>85</b>
<b>Annex 2</b>	<b>Personal Protective Equipment List .....</b>	<b>87</b>
<b>Annex 3</b>	<b>List of Tools .....</b>	<b>88</b>
<b>Annex 4</b>	<b>Installation and Debugging Instructions .....</b>	<b>91</b>
Annex 4.1	Preparations Before System Installation .....	91
Annex 4.1.3	System Inspection.....	99
Annex 4.2	System Operation and Debugging Procedures.....	99
Annex 4.2.2	BMS System Operation Procedures .....	99
Annex 4.2.3	PCS Operation Procedures .....	100
Annex 4.2.4	Battery Replacement.....	100
Annex 4.2.5	Equipment Parameter Settings .....	121

---

---

Annex 4.2.6 System Debugging.....	128
<b>Annex 5 Alarm and Fault Handling Instructions.....</b>	<b>132</b>
Annex 5.1 Operational Procedures for C&I Integrated Cabinet .....	132
Annex 5.2 System Alarms and Handling .....	132
Annex 5.2.1 LEMS Alarm Information .....	132
Annex 5.2.2 BMS Alarm Information .....	137
Annex 5.3 BMS Troubleshooting .....	143
Annex 5.4 Battery PACK Replacement .....	144
Annex 5.5 Liquid Cooling Unit Troubleshooting .....	144
Annex 5.6 PCS Troubleshooting .....	149
Annex 5.7 Fire Product Troubleshooting .....	168
Annex 5.7.1 Combustible Gas Detector Troubleshooting .....	168
Annex 5.8 Dehumidifier Troubleshooting.....	169
Annex 5.9 UPS troubleshooting .....	170
Annex 5.10 System Processing.....	171
<b>Annex 6 System Maintenance Instructions.....</b>	<b>172</b>
Annex 6.1 System Maintenance .....	172
Annex 6.2 C&I Integrated Cabinet Power-Off Operation Procedure .....	172
Annex 6.3 Battery PACK Maintenance.....	173
Annex 6.3.1 Battery PACK Maintenance Procedure.....	173
Annex 6.3.2 Battery PACK replacement .....	177
Annex 6.4 Liquid Cooling Unit Maintenance Procedure.....	183

---

---

Annex 6.4.1 Liquid Cooling Unit Replacement.....	186
Annex 6.4.2 Liquid Cooling Pipeline Replacement .....	189
Annex 6.4.3 Instructions for Liquid Replenishment After Equipment Replacement .....	189
Annex 6.4.4 Normal Operation and Maintenance Liquid Replenishment Operation Instructions .....	196
Annex 6.5 Fire Safety System Maintenance Procedure.....	196
Annex 6.5.1 Fire Safety System Equipment Replacement Steps.....	200
Annex 6.6 PCS Maintenance Procedure.....	205
Annex 6.6.1 Daily Inspection Items .....	207
Annex 6.6.2 Regular Inspection Items .....	207
Annex 6.6.3 PCS Replacement Steps .....	209
Annex 6.7 Dehumidifier Maintenance Procedure.....	211
Annex 6.8 Power Distribution Component Maintenance.....	211
Annex 6.9 Replacement of High Voltage Box Components.....	216
Annex 6.10 Cooling Fan Maintenance .....	217
Annex 6.11 UPS Maintenance Procedure .....	219
Annex 6.11.1 Equipment Maintenance.....	219
Annex 6.11.2 Storage Equipment.....	219
Annex 6.12 Circuit Breaker Maintenance Procedure .....	220
Annex 6.12.1 Circuit Breaker Maintenance.....	220
Annex 6.12.2 Miniature Circuit Breaker Replacement .....	221
Annex 6.13 Cabinet Maintenance .....	223

# 1 Preface

This operation and maintenance manual is applicable to the CPS ES-125kW/261kWh-EU liquid-cooled Commercial and Industrial (C&I) integrated cabinet (hereinafter referred to as the "integrated cabinet") developed and produced by Shanghai Chint Power Systems Co., Ltd.

---

## Important



- Please hand over this manual to a designated person for safekeeping.
  - Before performing any operations, please read this manual carefully and ensure that you fully understand all the contents.
- 

## Main Content

This manual includes instructions on how to operate the integrated cabinet (such as how to debug and properly shut down the integrated cabinet), the maintenance plan for the integrated cabinet, and considerations for the handling and recycling of system hardware. Therefore, before using this system, please be sure to read this manual carefully and operate the integrated cabinet according to the methods described in this manual, otherwise it may cause equipment damage or personal injury.

## Target Audience

This manual is suitable for users, after-sales service engineers, installation and commissioning engineers, and other operators.

It mainly explains the system composition, unpacking inspection, power on/off operations, daily inspection and maintenance items during use, and emergency response.

## Copyright Restrictions

The content of the manual and the pictures and logos used in the manual are all owned by Shanghai Chint Power Systems Co., Ltd. Without written authorization, partial or full content may not be publicly reproduced.

---

**Version upgrade**

Due to product updates and improvements, the manual content will be updated, adjusted, and revised accordingly. Please refer to the actual product for the product you purchased. You can obtain the latest version of the manual materials through the corresponding sales channels, or you can log in to our official website <http://www.chintpower.com> to download the latest version of the operation and maintenance manual.

## 2 Safety Information Instructions

Adhering to the following warnings, safety instructions, and precautions can ensure safety, extend the product's service life, and prevent property damage. The system location should be addressed through effective equipment operation, design, specifications, and installation to minimize personnel exposure to electrical hazards. All electrical work should be completed by qualified and authorized service personnel who have received appropriate training, in accordance with the latest local electrical, building, fire, and other codes, standards, regulations, or utility requirements applicable to the installation, following relevant instructions and appropriate practices. If the installation is not carried out in accordance with the safety instructions in this manual, resulting in personal injury or equipment damage, our company reserves the right not to assume responsibility and quality assurance!

The following precautions provide general safety guidelines to follow when using or being near an integrated cabinet. Complete safety parameters and procedures are specific to each project and should be developed by the customer or end-user based on the actual conditions of the project.

Only authorized and fully trained electrical operators are allowed to enter the system. Establish a clear, permanent, and restricted access area around the system.

Depending on the actual project site, consult local regulations and applicable rules to determine permit requirements. If necessary, properly mark the enclosure before starting work.

### 2.1 Warning Content in this Manual

Before reading the manual, please note several safety warning messages. These messages are very important, and familiarizing yourself with them can make you safer during installation and operation.

#### **Qualified operators:**

- Operators must be fully familiar with all warnings and installation steps described in the installation manual!

- Only qualified personnel who hold valid electrical knowledge certificates or qualifications, comply with regulatory requirements and safety standards, and have extensive experience in this type of work can operate on circuits and equipment.
- Only qualified personnel familiar with battery PACK and safety precautions can perform the installation and operation of battery PACK. Do not allow unauthorized personnel to access the battery PACK.

**Electrical safety operations:**

- All live electrical work requires a live work permit. A qualified operator should release all stored electricity, verify that the equipment is de-energized, and perform appropriate lockout/tagout procedures before starting electrical work.
- When working near live overhead power cables, equipment such as booms, masts, cranes, or their loads must never be within the assessed distance limits of the power cables.
- On-site electrical installations, even if considered temporary, must be planned and manufactured in an appropriate manner, using materials and industrial electrical components, to ensure the normal operation of the equipment and the integrity of the employees.

**Battery PACK safe handling:**

Please note that the battery PACK poses a risk of electric shock, including high short-circuit current. When handling the battery PACK, please follow all safety precautions:

- Do not smoke or use fire near the battery PACK!
- Do not clean the battery with organic solvents!
- Do not put the battery PACK into fire, otherwise it may explode!
- Do not disassemble the battery PACK, the battery PACK contains electrolyte that is harmful to skin and eyes!
- Do not place tools or any metal parts on top of the battery PACK!
- Remove watches, rings, and other metal accessories!







- Use tools with insulated handles to avoid accidental short circuits!
- Before connecting or disconnecting the terminals, disconnect the charging source and the load!
- Use appropriate lifting methods when moving the battery PACK, and wear all appropriate safety clothing and equipment!
- Keep 0.5m away from heat sources or any place that may generate sparks (such as circuit breakers, fuse boxes, etc.)!
- Avoid the risk of local overheating, such as direct sunlight on the battery rack!
- The battery PACK must be handled, transported, recycled, or discarded according to local regulations!

**Installation Notes:**

- Before installation, all Personal Protective Equipment (PPE) required to supervise the installation process should be in place, see Annex 2 Personal Protective Equipment List (PPE).
- Installers should receive safety training before installation and fill out the Safety Installation Training Record Form, see Annex 1 Safety Training Records.
- Unless appropriate power-off measures are taken, all power cables are considered to be live.
- Please ensure to cut off the grid power before installation and make sure the battery is in the off state.
- All battery racks must be grounded with good conductors to form a good grounding network.
- The fixing screws at the battery terminals and the power interface of the BMS high voltage box are M8 external hexagon screws, with a tightening torque range of 19~24 N·m, and should be fixed using a torque wrench.

- Before the electrical performance test, check whether the cable bolts and bronze bolts are loose. If looseness is found, tighten them with a special tool.

## 2.2 Warning Labels on the Equipment

Symbols	Meaning
	<p>Warning - Electric Shock Hazard! Do not touch system connectors or terminals. Do not open the closed door unless proper lockout/tagout procedures and related training have been performed in accordance with local regulations and requirements.</p>
	<p>Warning - Arc Flash Hazard! All electrical equipment presents arc flash hazards. Operational or maintenance activities (including door opening, breaker operation, etc.) may trigger severe arc flash incidents, resulting in fatal injuries. Professional training and arc flash protection measures must be implemented in strict accordance with local regulations.</p>
	<p>Warning - Fire hazard! Fire may occur under certain fault conditions.</p>
	<p>Caution - Sharp objects! There are multiple sharp objects in most system components. Please note that working around the equipment enclosure can easily trigger a risk of serious injury.</p>
	<p>Caution - Electrostatic sensitive! Electrostatic discharge can damage electronic equipment. Correct handling procedures are required. Please wear a grounded anti-static wrist strap and prevent electrostatic discharge when touching grounded surfaces near the equipment.</p>
	<p>Dangerous voltage! The integrated cabinet supports multiple power supplies. Even when the equipment is not operating, dangerous voltage may be present. Please ensure you fully understand the precautions and warnings in this installation manual. Failure to do so may result in serious injury or death. Follow all safety procedures issued by the manufacturer.</p>

## 2.3 Safety Requirements for the Owner

The owner must ensure the following requirements:

- Personnel operating the integrated cabinet must be trained and qualified electrical workers; otherwise, they cannot operate the integrated cabinet. Improper or incorrect operation may cause serious harm to the operator;
- Personnel operating the integrated cabinet should be thoroughly familiar with the working principles of the integrated cabinet ;
- Personnel operating the integrated cabinet should be thoroughly familiar with this manual;
- Personnel operating the integrated cabinet should be thoroughly familiar with local electrical regulations and standards;
- Regularly inspect the safety equipment within the system to ensure that the safety equipment is reliable;
- Any warning signs on the equipment that are damaged or illegible should be replaced immediately;
- No flammable or explosive items should be stored inside or near the integrated cabinet;
- The ground where the integrated cabinet are stored must be solid and reliable;
- Transportation, installation, and commissioning can only be performed by professionals designated by the manufacturer;
- Before operating the integrated cabinet, please evaluate events that may cause system hazards and handle these events;
- The description of safety in this manual is quite detailed. Please read it carefully and fully understand it;
- Do not change the software, casing, or internal components of the equipment without the manufacturer's approval; if unauthorized changes are made, the quality assurance of the integrated cabinet will be invalid;

- The sealing strip on the equipment must not be damaged. If damaged, the quality assurance of this equipment will be invalid.
- When maintaining a liquid-cooled battery system, maintain the battery clusters sequentially. That is, when maintaining a specific battery cluster, only the corresponding battery compartment door of that cluster may be opened; it is strictly prohibited to open multiple battery compartment doors simultaneously (unless multiple clusters require simultaneous maintenance operations).
- During the normal operation of the liquid-cooled battery system, opening battery compartment doors is not allowed. To open them, wait until the system operation is completed before performing operations and maintenance.
- After the liquid-cooled battery system maintenance is completed, the battery compartment doors should be closed immediately; after the doors are closed, the dehumidification air conditioner must first operate to control the humidity inside the compartment to 50% before the system can operate again.

## **2.4 Lockout/Tagout Guidance**

### **2.4.1 Danger**

Always follow all applicable lockout/tagout procedures. Failure to follow proper lockout/tagout procedures may result in serious injury or death.

When power is applied to the integrated cabinet, dangerous voltages exist on certain components. To prevent accidental death or injury, non-professionals should not touch any components inside the enclosure. To reduce the risk of electric shock, ensure all equipment is reliably grounded. For more information, refer to section 3.9 Grounding Wire.

### **2.4.2 Warning**

The doors of the Commercial and Industrial (C&I) integrated cabinet must remain closed unless access to the interior is required. If possible, personnel should maintain

a safe distance from the enclosure when the equipment is powered. When working near the C&I integrated cabinet, always comply with local and national lockout/tagout guidelines. Lockout and tagout procedures must meet or exceed the aforementioned requirements.

All guidelines proposed in the Chint safety document. Before entering a potentially hazardous area or starting work on the integrated cabinet, please complete the following regulations:

- Identify and wear protective clothing and protective shoes.
- Identify and isolate all power sources and stored energy.
- Use appropriate lockout/tagout devices. When locking/tagging the integrated cabinet, do not touch anything inside the Commercial and Industrial (C&I) integrated cabinet unless explicitly instructed in the work procedure.
- Before starting work, complete the site-specific lockout/tagout procedures and safety checklist.

### **2.4.3 General Warning**

- When powered on, this system poses potential risks of electric shock, death, and burns. Only authorized personnel who are fully familiar with the equipment and adequately trained may install, operate, or maintain this device.
- To avoid death, personal injury, or product damage, please follow all safety procedures specified in the national "Environmental Health and Safety (EHS) Guidelines" and isolate all power sources and stored energy.
- To avoid the dangers of electric shock, death, and burns, strictly adhere to approved grounding practices and procedures.
- To avoid personal injury and equipment damage, personnel working at heights must comply with the national "High Altitude Work Site Regulations."

- To avoid personal injury or equipment damage caused by equipment failure, only personnel who have received relevant training can modify any programmable machine.
- Always ensure compliance with local relevant standards and regulations.
- Certified equipment is used as a critical component of the safety system. Never assume that a safety-critical control loop is functioning properly; always follow the procedures during operation.

Please note the warning signs inside and outside the liquid-cooled Commercial and Industrial (C&I) integrated cabinet.

Warning signs inside the integrated cabinet



Please read the manual carefully



Warning



Danger of electric shock



Recycle

Warning signs on the exterior of the integrated cabinet



Arc flash warning



Emergency shutdown



Fire hazard



Danger of electric shock



Warning



Read carefully



Do not discard at will

## 2.5 Terms and Definitions

Terms	Definitions
Battery PACK	Battery assembly consisting of battery cells connected in series, parallel, or both, with a pair of positive and negative output terminals, which should also include housings, management and protection components.
High voltage box	It is used for the protection and control during charging and discharging of battery cluster, and consists of the cluster-level battery management unit, relay, fuse, power resistor and disconnecter.
Battery cluster	Battery assembly that is connected by the battery PACK in series and can run independently after being connected with a PCS and ancillary facilities, which shall also include the battery management system, monitoring and protection circuit, electrical and communication interfaces and other components.
PCS	Power Conversion System, accepts the EMS or BMS requirements, and charges and discharges batteries.
BMS	Battery Management System, used to detect the voltage, current, temperature and other parameter information of the battery and manage and control the state of the battery.
ESBMM	Energy Storage Battery Management Module, the slave module in BMS, which is used to collect the voltage and temperature of single battery in the battery PACK, control fans, and achieve the balance management of battery.
ESBCM	Energy Storage Battery Control Module, the main control module in BMS, which enables the real-time monitoring of battery cluster parameters, fault handling, SOC/SOH estimation, insulation detection, alarm display, remote monitoring, relay control, equalization algorithm, and collection of total voltage and main loop current, communication with ESBMM in the system BMS, and

	communication with the master control module and uploading of real-time battery data.
ESMU	Energy Storage Management Unit, the master control module in BMS, which communicates with the main control module to query the information inside the module, and summarizes the information of multiple battery clusters; communicates with HMI to query on the corresponding HMI; communicates with the background to query in the corresponding background; communicates with PCS to control the charging and discharging of PCS; and inputs and outputs dry contacts as required, and communicates with air conditioning, fire protection and other system equipment as required.
EMS	Energy Management System of the whole power station, used for dispatching, monitoring and management of the whole power station.
LEMS	Local Energy Management System, also local controller, used for managing the local equipment.
Distribution box	It is mainly used to supply power to the system communication components and system equipment, and is arranged in the equipment compartment.
Fire protection system	Mainly including aerosol, detector, audible and visual alarm, etc., which are arranged in the battery compartment.
Thermal management system	Use a liquid cooling unit to adjust the battery temperature within an appropriate range, and uniformly control the temperature of each battery through liquid cooling pipelines and liquid cooling plates.
Circulation	When the battery PACK is charged and discharged once as per the specified standard, it is considered as a cycle.
MSD	Maintenance Switch Disconnecter, used as a manual maintenance switch.

Measurement unit	Unit of voltage: "V" (volt) Unit of current: "A" (ampere) Unit of power: "W" (watt) Unit of capacity: "Ah" (Ampere-Hour) Unit of energy: "Wh" (Watt-Hour) Unit of internal resistance: "mΩ" (milliOhm) Unit of temperature: "°C" (degree Celsius) Unit of length: "mm" (millimeter) Unit of time: "s" (second) Unit of frequency: "Hz" (Hertz) Unit of mass: "kg" (kilogram) Unit of force: "N" (Newton)
---------------------	---

## 3 System Introduction

### 3.1 System Applications

The CPS ES-125kW/261kWh-EU liquid-cooled Commercial and Industrial (C&I) integrated cabinet adopts a modular design concept and is widely used in scenarios such as renewable energy integration, commercial and industrial (C&I), and utility applications. The system features an "All in one" design, eliminating the need for auxiliary electrical design and reducing on-site workload. At the same time, the top explosion-proof design significantly enhances fire safety. The system supports flexible 2/4-hour configuration schemes and offers higher energy density, superior cycle efficiency, and longer service life, ensuring efficient and reliable long-term operation. The integrated cabinet is mainly suitable for system solutions such as BCP (Business Continuity Plan, emergency power supply in case of accidents or disasters), peak shaving and valley filling, Photovoltaic (PV) self-consumption, Virtual Power Plant (VPP) or grid dispatch, improving energy utilization efficiency and enhancing power quality. The integrated cabinet has advantages such as high efficiency, energy saving, environmental protection, high integration, easy installation, standardized solutions, intelligent control, remote monitoring, and easy operation, with stable performance, safety, reliability, and long service life.

### 3.2 System Functions

**Intelligent Management:** The integrated cabinet is composed of high-capacity battery cells, serving as an intelligent energy storage device that supports management, dispatch, grid connection, black start, and easy transportation. The main components of the system include the PCS, BMS, and battery PACK. The PCS performs stable charging and discharging of battery clusters based on the battery status and operational mode requirements provided by the LEMS or BMS.

**High Reliability:** The BMS ensures the battery cells always operate well through real-time monitoring, automatic balancing, automatic inspection protection, and power data requests. The black start system supports the operation of the energy storage power station during power outages, solving customers' electricity usage

challenges.

**High Flexibility:** The entire station's Energy Storage System (ESS) can be flexibly configured according to user requirements. It can be designed for grid-connected wind/PV energy storage, off-grid energy storage, etc., making it a powerful, stable, reliable, and technically comprehensive energy storage product.

## 3.3 System Description and Parameters

### 3.3.1 System Description Scope

Battery cluster, BMS, LEMS, PCS, connecting cables, communication cables, power supply equipment, communication equipment, protection equipment, and complete auxiliary systems such as temperature control and fire protection, to complete the installation and internal connection of the system.

Guidelines for usage, maintenance precautions, emergency instructions, and fault handling during equipment operation.

### 3.3.2 System Annotation

This C&I integrated cabinet product consists of multiple energy storage components, including LEMS, thermal management system, fire safety system, power distribution system, BMS, PCS, and the most important battery PACK. The detailed system annotation is shown in the following figure:

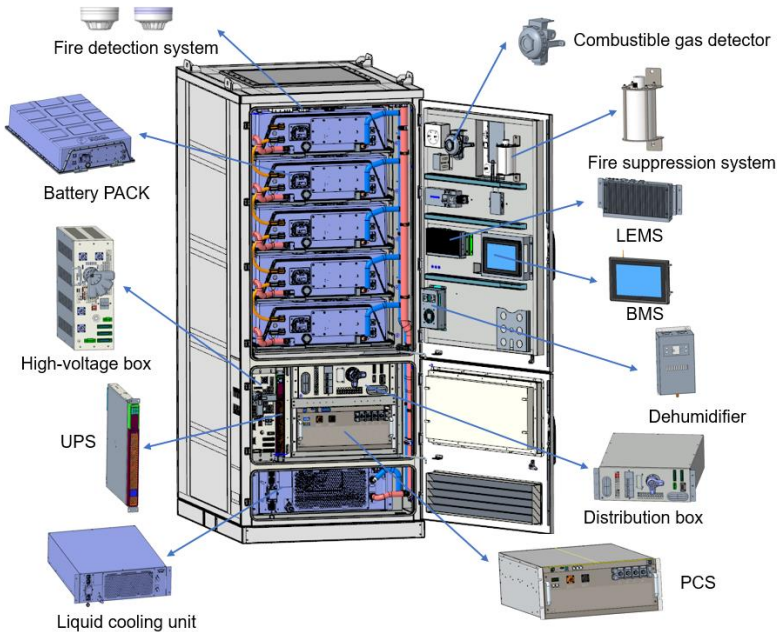

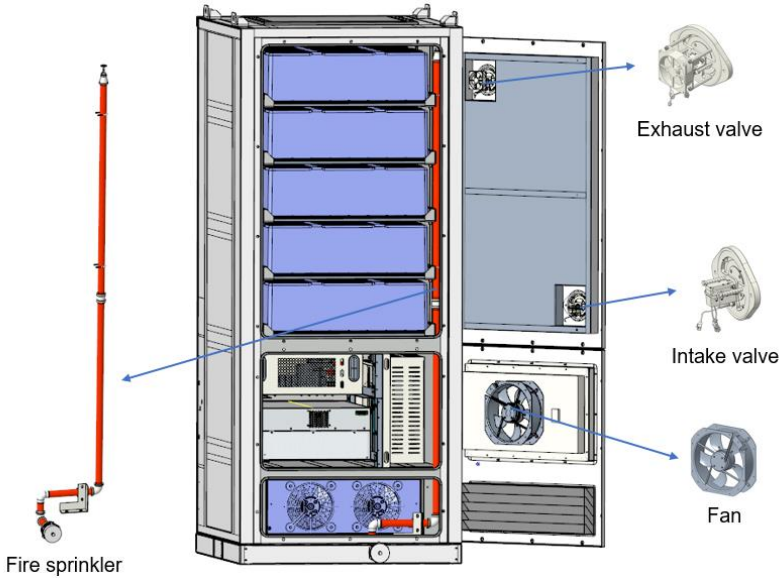

Figure 3-1 System component annotation diagram

### 3.3.3 System Detailed Parameters

The technical parameters of this integrated cabinet product are based on the test results of standard battery clusters under room temperature ( $25 \pm 2$ )°C and humidity ( $55 \pm 20$ )%. For detailed parameters, please refer to the following table:

Table 3-1 System detailed parameters

Project	Parameter	Condition
Battery cell capacity	314Ah	0.5C charge-discharge rate
Series-parallel configuration	1P260S	N.A.
DC nominal voltage	832V	N.A.
DC Nominal Capacity	261.248kWh	Standard Discharge

Project	Parameter	Condition
AC Side Output Voltage	400V,3P4W	AC Side Grid Voltage
Output Bus Rated Current	150A	Energy Storage
Critical load maximum power	The power of pure resistive load $\leq$ the rated power of PCS, supporting 100% load capacity; The power of pure inductive load $\leq$ 15%~20% of the rated power of PCS; The power of load with inverter $\leq$ 60% of the rated power of PCS.	
Overall dimensions	1000*1416*2415mm	Refer to the drawing for details, water spray and lifting rings are not included
Weight	< 3T	Fully loaded
Discharge cutoff voltage	728V or any battery cell in the battery cluster reaches 2.8V	Temperature $T > 0^{\circ}\text{C}$
Charge cutoff voltage	936V or any battery cell in the battery cluster reaches 3.6V	N.A.
Rated charge/discharge current	157A	$(25 \pm 2)^{\circ}\text{C}$
Communication method	CAN, RS485, TCP/IP	N.A.

Project	Parameter	Condition
Operating temperature range	-25°C~55°C ( >45°C derating )	N.A.
Storage temperature range	-30~60°C	N.A.
Recommended operating temperature	(25±5) °C	Operating within this temperature range ensures product lifespan
System thermal management method	Battery: liquid cooling; PCS: forced air cooling	N.A.
Fire Safety System	Aerosol	Other gas extinguishing media can be replaced according to customer requirements, and a water spray system can be optionally configured
Protection level	Battery compartment IP55, equipment compartment IP54	N.A.
Noise	< 75dB	At a distance of 1 m and a height of 1.7 m, 35°C
Rated AC output power	125kVA	
Rated frequency	50Hz	

Project	Parameter	Condition
Measurement Accuracy	Class 0.5 (Bidirectional Meter)	
Auxiliary Power Supply	Self-powered, with 650VA UPS	

### 3.4 System Architecture Diagram

#### 3.4.1 Electrical Architecture Diagram

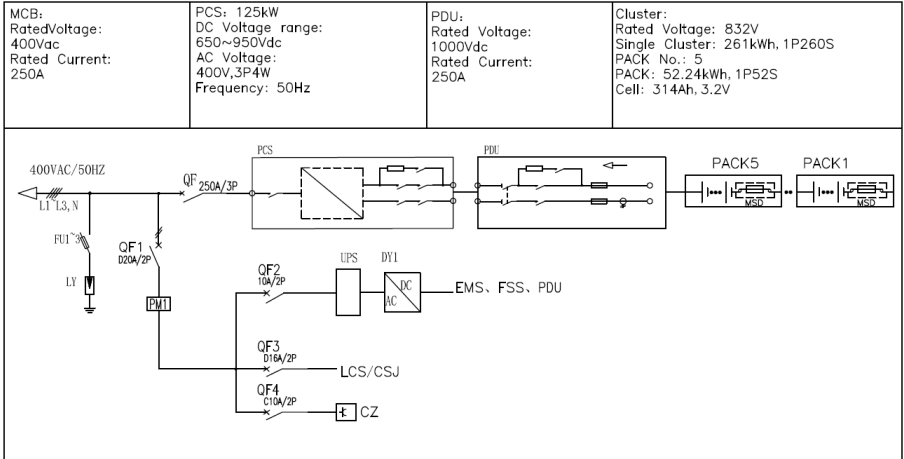

Figure 3-2 System electrical architecture diagram

#### 3.4.2 Communication Architecture Diagram

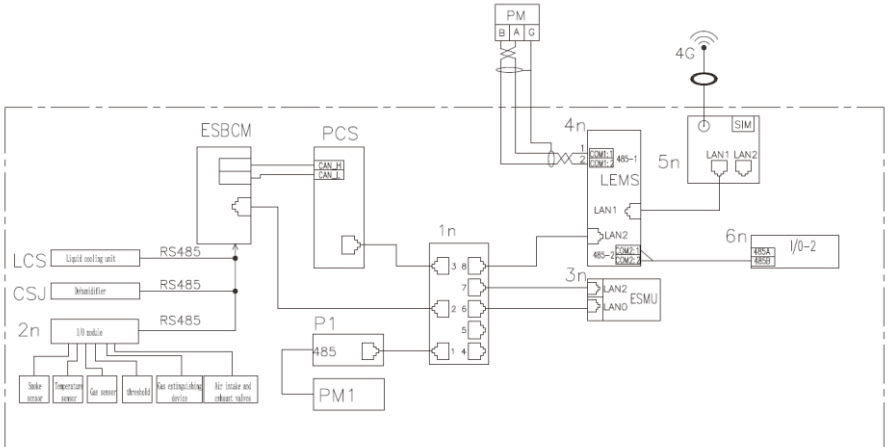
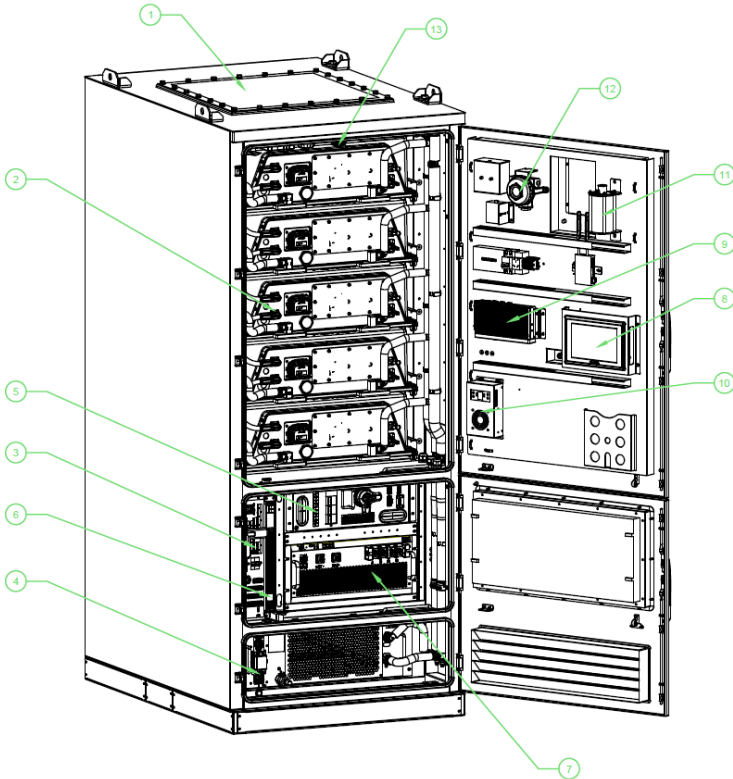

Figure 3-3 System communication architecture diagram

### 3.4.3 System Equipment Layout Diagram



No.	Name	No.	Name
1	Explosion relief panel	8	BMS
2	Battery PACK	9	LEMS
3	High voltage box	10	Dehumidifiers
4	Liquid cooling unit	11	Fire suppression system
5	Distribution box	12	Combustible gas detector
6	UPS	13	Smoke detector, Temperature detector
7	PCS		

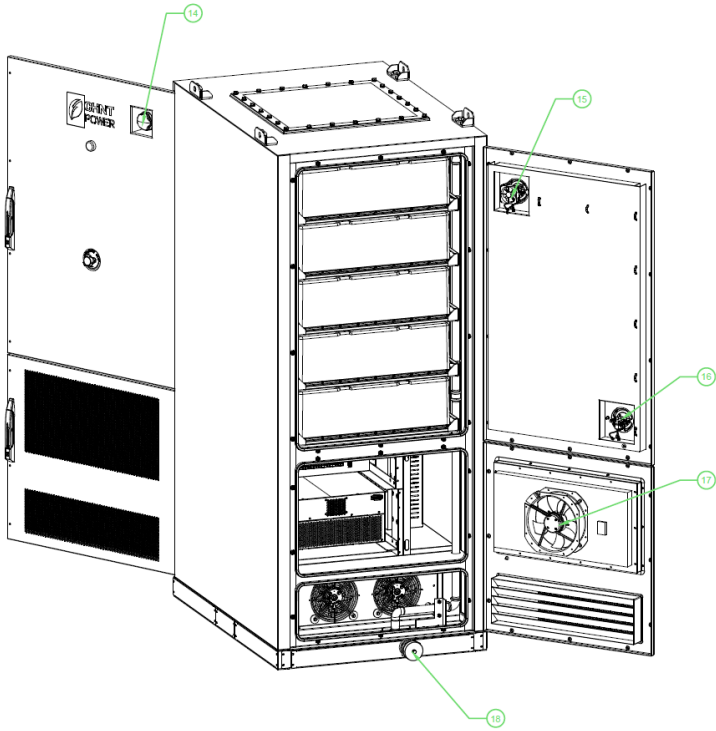
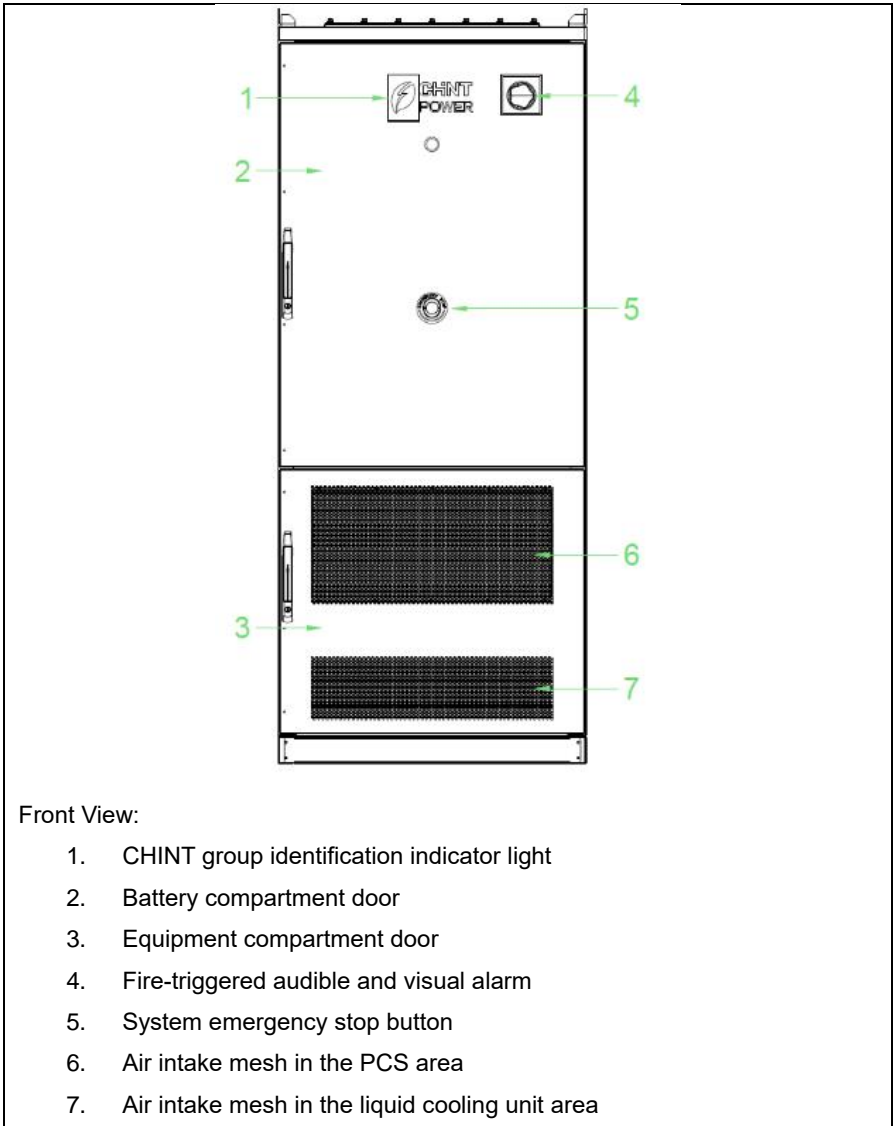
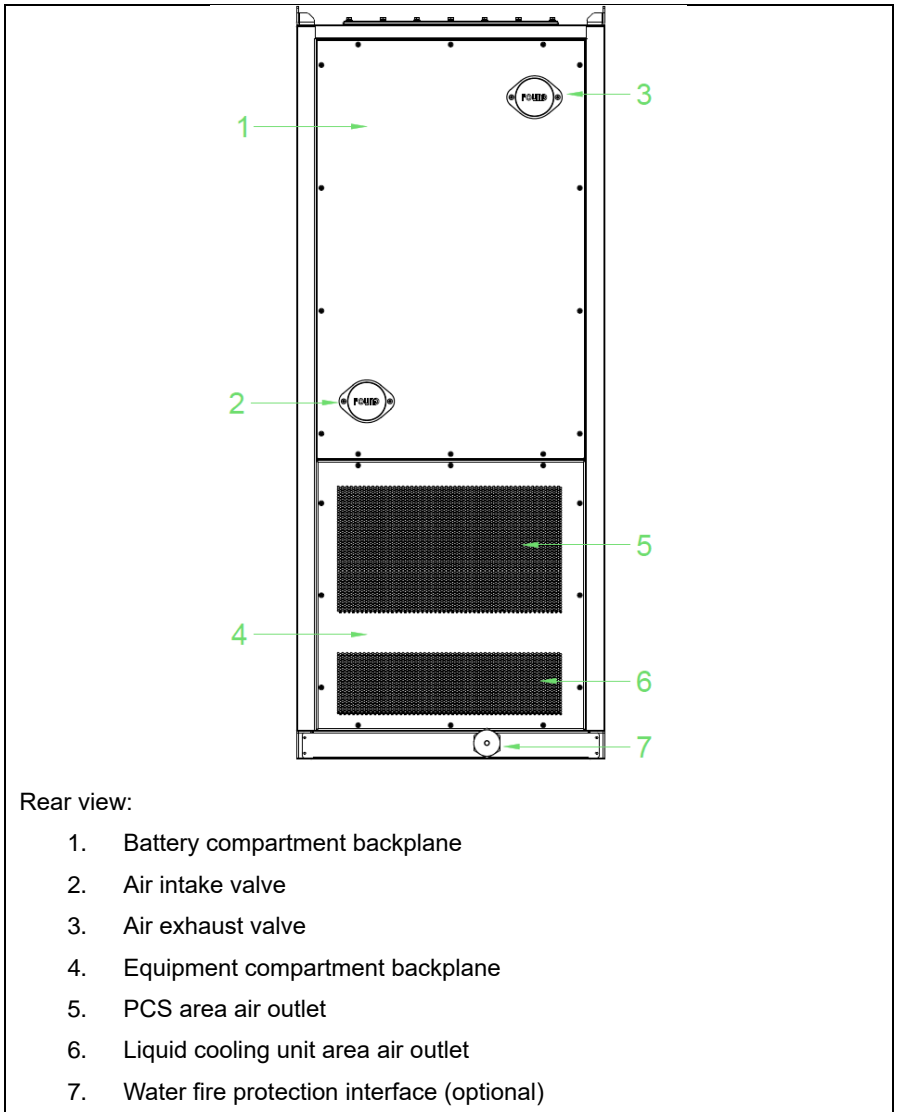

Figure 3-4 Equipment layout diagram

No.	Name	No.	Name
14	Audible and visual alarm	17	Fan
15	Exhaust valve	18	Fire sprinkler
16	Intake valve		

The descriptions of each system view are as follows:





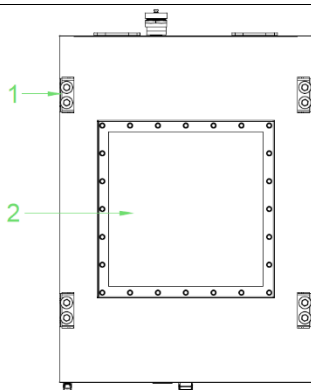

Top view:

1. There are 4 lifting rings arranged on the top of the integrated cabinet, which is convenient for on-site hoisting;
2. Explosion relief panel, used for product explosion relief.

### 3.4.4 System Incoming and Outgoing Lines

To facilitate on-site cable connections, all cables between internal devices of the integrated cabinet product are connected before leaving the factory.

The cables between the integrated cabinet product and external devices are routed through the bottom of the cabinet. All cables entering and exiting the integrated cabinet should be properly protected, such as using cable conduits to prevent rodent damage. After cable connections are made, all cable entry points should be sealed with fireproof mortar or other appropriate materials.

The cable entry and exit holes at the bottom of the integrated cabinet product are shown in the following figure.

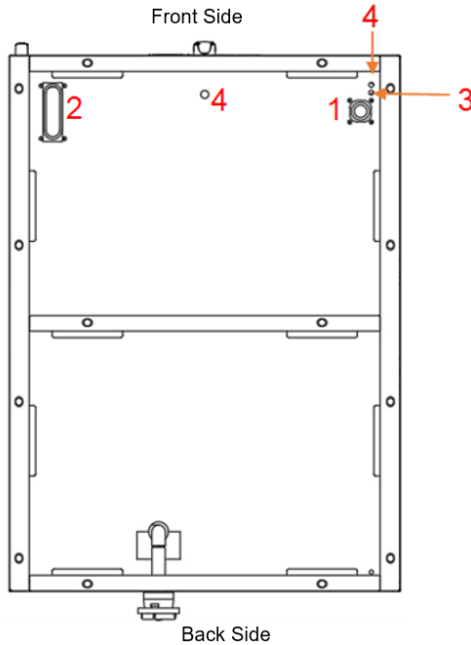

Figure 3-5 Cable entry and exit holes

The function of each cutout is as follows:

Table 3-2 Cutout function

No.	Name	Cutout Dimensions	Description
Hole 1	Communication cable, grounding cable inlet	φ40mm	Communication cables and cabinet grounding cables are connected to external devices through this hole.
Hole 2	AC power cable inlet	φ40x130mm	AC power cables are connected to external devices through this hole. Customers can drill holes according to their actual needs.
Hole 3	Dehumidifier water hole	N/A	The water pipe on the dehumidifier passes through the water hole to drain the water generated by dehumidification outside the cabinet.
Hole 4	Rainwater hole	N/A	Rainwater inside the integrated cabinet is drained through this hole.

The dimension of the compression lug of AC cable is as follows:

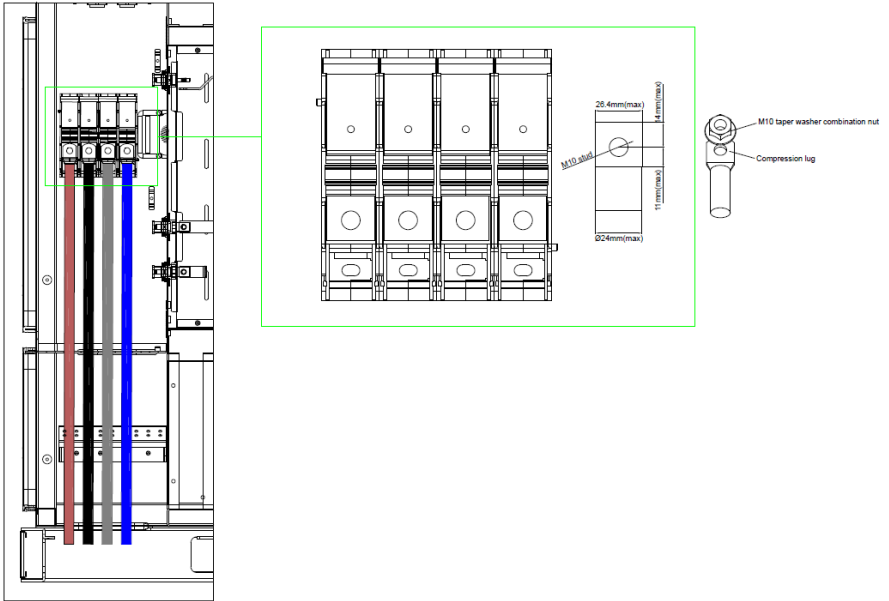

### 3.4.5 Nameplate

Users can identify the integrated cabinet through the nameplate, which is located at the lower right corner of the front door of the cabinet, as shown in the following figure. Detailed nameplate information is shown in Figure 3-7.

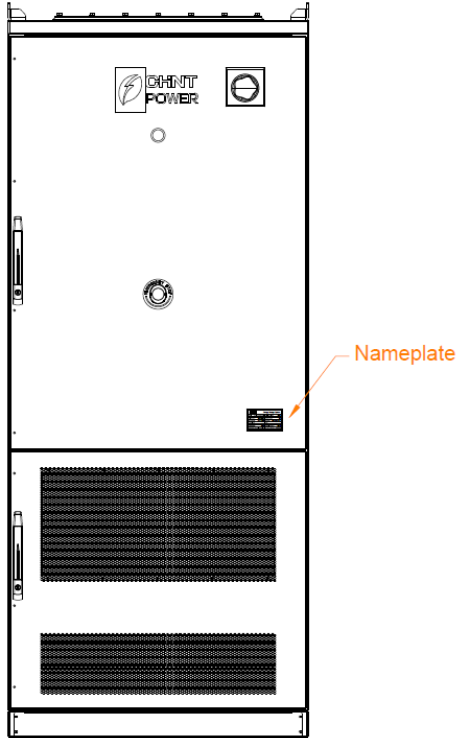

Figure 3-6 Nameplate location

		Energy Storage System	
Model:	CPS ES-125kW/261kWh-EU	Installation Altitude:	≤2000M
Nominal Voltage:	832Vdc	Class Classification:	Class I
Voltage Range:	728Vdc-936Vdc	Protection Level:	IP54
Rated Capacity:	314Ah, 261kWh	Dimensions:	1000x1370x2415mm
Charge Voltage:	936Vdc	Mass:	2535±100kg
Discharge Voltage:	728Vdc	Country of Manufacture:	China
Grid Frequency:	50/60Hz	Date of Manufacture:	2025/03
Battery designation:	IFP73/176/208/155(1P52S)]E/-20+55/95	Operating Temperature:	-25°C~55°C (>45°C Reduce power)
Shanghai Chint Power Systems CO., LTD.			

Figure 3-7 Nameplate details

The information contained in the nameplate includes:

1. Product name, specifications, and model;
2. The name and trademark of the manufacturer;
3. Technical parameters:
  - System operating parameters: rated output voltage (V), rated output current (A), rated capacity (kWh), rated operating frequency (Hz), etc.;
  - Hardware parameters: altitude (m), dimensions (mm), weight (kg);
  - Operating temperature.



### Warning

The parameters on the nameplate are very important, and it is strictly prohibited to damage or remove the nameplate!

### 3.5 Battery Management System

The BMS adopts a 3-level architecture, and the hardware consists of ESBMM, ESBCM, and ESMU. The installation locations of the BMS components are as follows:

Table 3-3 Installation locations of BMS components

Device level	Device name	Installation location	Function
Level 1, Battery PACK level	ESBMM	Inside the battery PACK maintenance panel	Detect the voltage and temperature information of the cells inside the battery PACK
Level 2, Battery cluster level	ESBCM	Inside the High voltage box	Data collection, analysis, and decision-making; Cluster-level protection; Information uploaded to ESMU;
Level 3, System level	ESMU	On the cabinet door	Collect information from each ESBCM and communicate with LEMS and SCADA

The schematic diagram of the installation location of ESMU in the battery compartment is as follows:

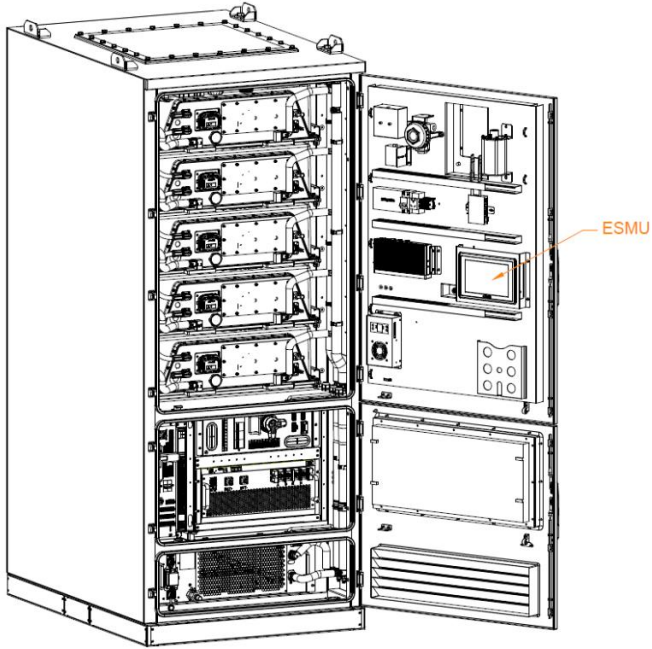

Figure 3-8 ESMU location

In the interface distribution of ESMU, Port A is the power port, LAN is the Ethernet communication port, Ports B, C, D, E, and F are communication ports, USB is the data export and firmware upgrade import port, and SW is the auxiliary firmware button.

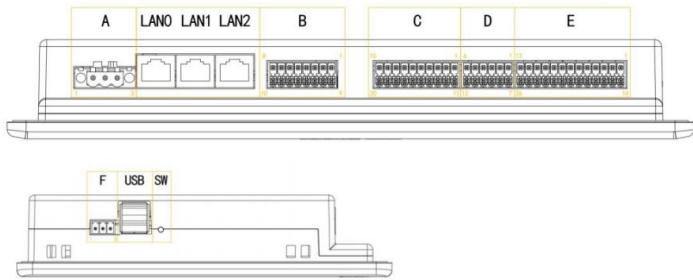

Figure 3-9 ESMU interface diagram

ESMU has a total of 11 output dry contact interfaces, located on all pins of Port E. The interface definitions of ESMU are as follows:

Table 3-4 ESMU interface definitions

Port name	No.	Port definition	Function description	Recommended use
A	1	V+	Power Supply Positive Input	Power Input
	2	V-	Power Supply Negative Input	
	3	PE	System grounding (protective earth bonding)	
LAN	-	LAN0	100M/1000M Ethernet	LEMS
	-	LAN1	100M/1000M Ethernet	LEMS
	-	LAN2	10M/100M Ethernet	ESBCM

### 3.6 Power Conversion System

The power conversion system is a conversion device between the grid and battery, which can charge and discharge the battery. It can invert DC power from the battery to AC power that can be connected to the grid and rectify AC power from the grid to DC power that can be charged into the battery. The power conversion system can be used in grid-connected mode or off-grid mode.

The power conversion system adopts single-stage topology, and the DC voltage input range is 750-1100V. The topological graph of the power conversion system is illustrated as follows:

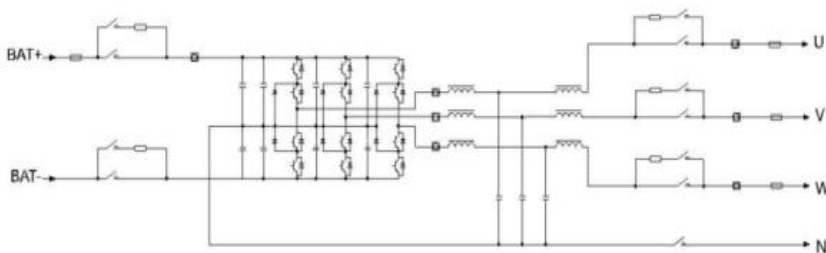

Figure 3-10 Topology diagram of PCS

For more details, please refer to the PCS user manual.

### 3.7 Battery System

The liquid-cooled battery system mainly consists of battery PACK, high voltage box, support frame, and BMS. The BMS adopts a 3-level architecture, with hardware composed of ESBMM, ESBCM, and ESMU. The ESBMM is pre-installed on the battery PACK panel, the ESBCM is pre-installed in the high voltage box, and the ESMU is pre-installed on the cabinet door.

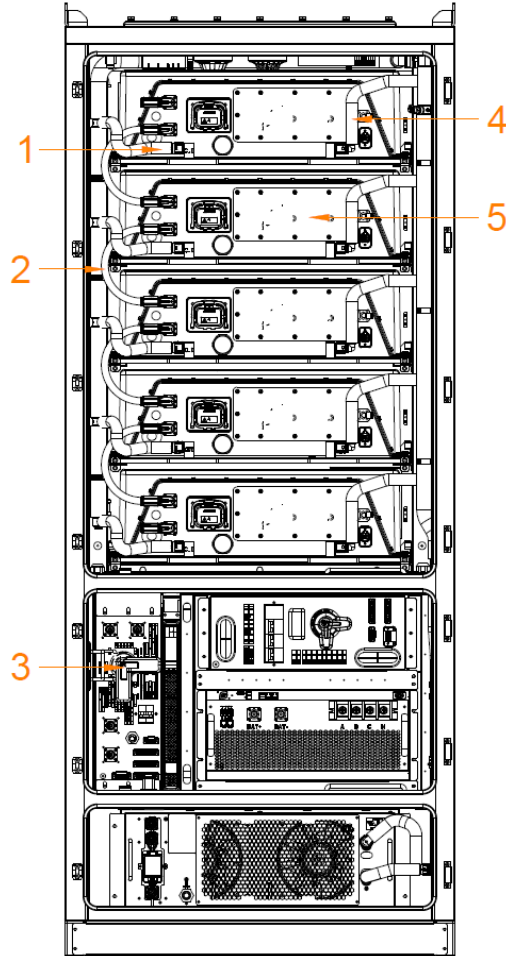

Figure 3-11 Battery cluster connection diagram

No.	Name
1	Liquid-cooling return pipe
2	Battery PACK connection cable
3	High voltage box
4	Liquid-cooling inlet pipe
5	Battery PACK

### 3.7.1 Battery PACK

The battery PACK is composed of Lithium Iron Phosphate (LFP) cells in a 1P52S configuration. The positive and negative positions of the Battery PACK are positive at the top and negative at the bottom, as shown below:

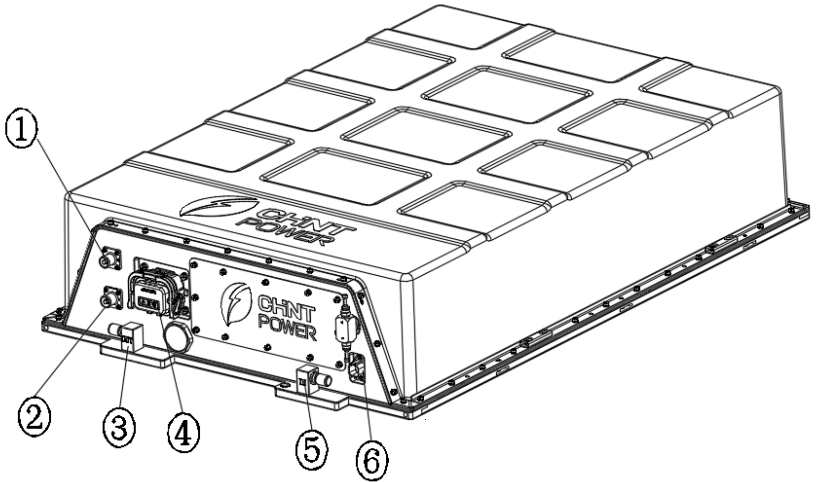

Figure 3-12 Battery PACK

Table 3-5 Battery PACK interface names

No.	Name
1	Positive terminal
2	Negative terminal
3	Liquid cooling outlet
4	MSD
5	Liquid cooling inlet
6	Communication interface

### 3.7.2 High Voltage Box

The high voltage box consists of protective devices and ESBCM. The layout of the high voltage box is shown in the following figure:

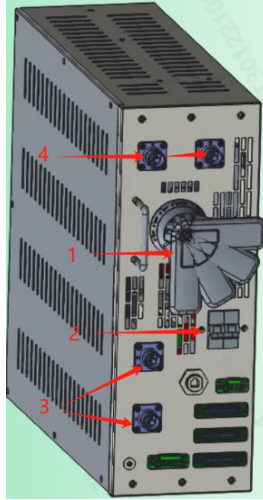

Figure 3-13 High voltage box

Table 3-6 Main interfaces of high voltage box

No.	Definition	Function description
1	Disconnecter	Realize high-voltage on/off control of the battery cluster's DC side.
2	Miniature circuit breaker	Protect the secondary signal circuit of the high voltage box, supporting overload/short-circuit protection.
3	Battery cluster plug	High voltage DC interface between the battery PACK and the high voltage box.
4	PCS plug	High voltage DC interface connecting the high voltage box to the PCS DC side.

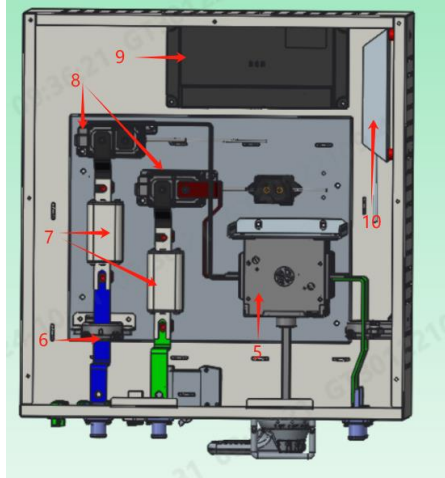

Figure 3-14 High voltage box interior

Table 3-7 High voltage box interior

No.	Definition	Function description
5	Disconnecter	Realize high-voltage on/off control of the battery cluster's DC side.
6	Hall sensor	Precisely measure the DC side current of the battery cluster and provide real-time fault feedback.
7	Fuse	Provide short-circuit protection for the DC side.
8	DC relay	Provide overcurrent protection for the DC side.
9	Main control (ESBCM)	Battery cluster energy management module (ESBCM): perform data acquisition, balance management, and trigger ESMU linkage protection during system faults.
10	Precharge resistor	Limit precharge current to prevent arcing at the main relay contacts.

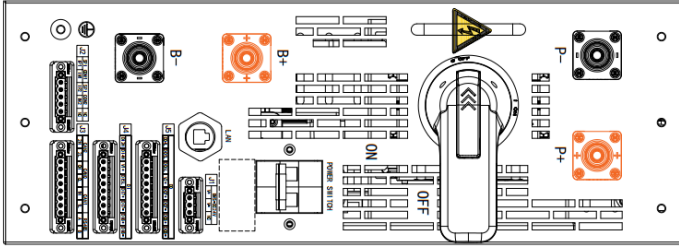

Figure 3-15 High voltage box interfaces

The high voltage box is connected to the battery through "B+" and "B-" terminals, and connected to the DC side of PCS through "P+" and "P-" terminals on the front of the control box. The schematic diagram of high voltage box interfaces is shown above, and the definitions of power and communication input/output interfaces are shown in the following table:

Table 3-8 Power and communication input/output interface definitions

Port name	No.	Definition	Function description	Remarks
BMS-DC24V Port J1	1	V+	External 24VDC power input, supplying power to internal components of the high voltage box	
	2	V+		
	3	/		
ESBMM communication port J2	1	IP1	Daisy chain communication	Connect to the last ESBMM IP2/IM2
	2	IM1	Daisy chain communication	
	3	IP2	Daisy chain communication	Connect to the first ESBMM IP2/IM2
	4	IM2	Daisy chain communication	
	5	/		
Communication port J3	1	2H	Reserved	
	2	2L		

Port name	No.	Definition	Function description	Remarks
	3	0H	Reserved	
	4	0L		
	5	1H	PCS communication	
	6	1L		
	7	A	Liquid cooling unit/IO module/dehumidifier communication	Hand in hand
	8	B		
ESBCM DI port J4	1	DI2H	Standby	
	2	DI4H	Standby	
	3	V1+	Standby	
	4	DI5L	Standby	
	5	DI7+	PCS fault feedback	
	6	DI7-		
	7	DI8+	Standby	
	8	DI8-	Standby	
ESBCM DO port J4	1	D04L	Red light	
	2	D05L	Green light	
	3	D06L	Standby	
	4	V2+	24V+	
	5	DO7+	Standby	
	6	DO7-		
	7	DO8+	Standby	
	8	DO8-	Standby	
RJ45	1	LAN	Display control communication	

### 3.8 Local Energy Management System

The Local Energy Management System (LEMS) is the energy dispatch and management center of the ESS. LEMS is the brain of the ESS, mainly responsible for collecting all BMS data, PCS data, and grid-side data, issuing control commands to various parts, controlling the operation of the entire ESS, and reasonably arranging the work of the PCS. The system can operate automatically according to preset charging/discharging time, power, and operation modes, or it can operate by accepting dispatch commands.

The schematic diagram of the installation position of the Local Energy Management System (LEMS) in the battery compartment is as follows:

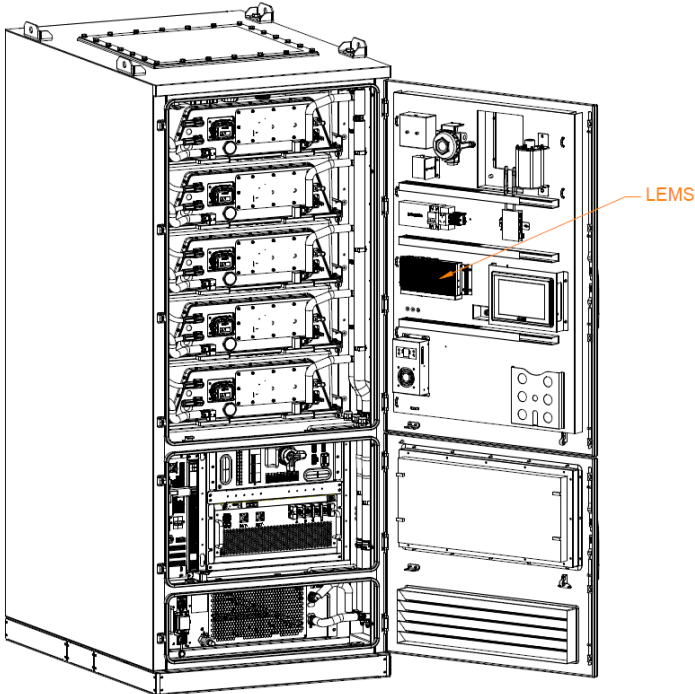

Figure 3-16 LEMS position

### 3.8.1 LEMS Control System Diagram

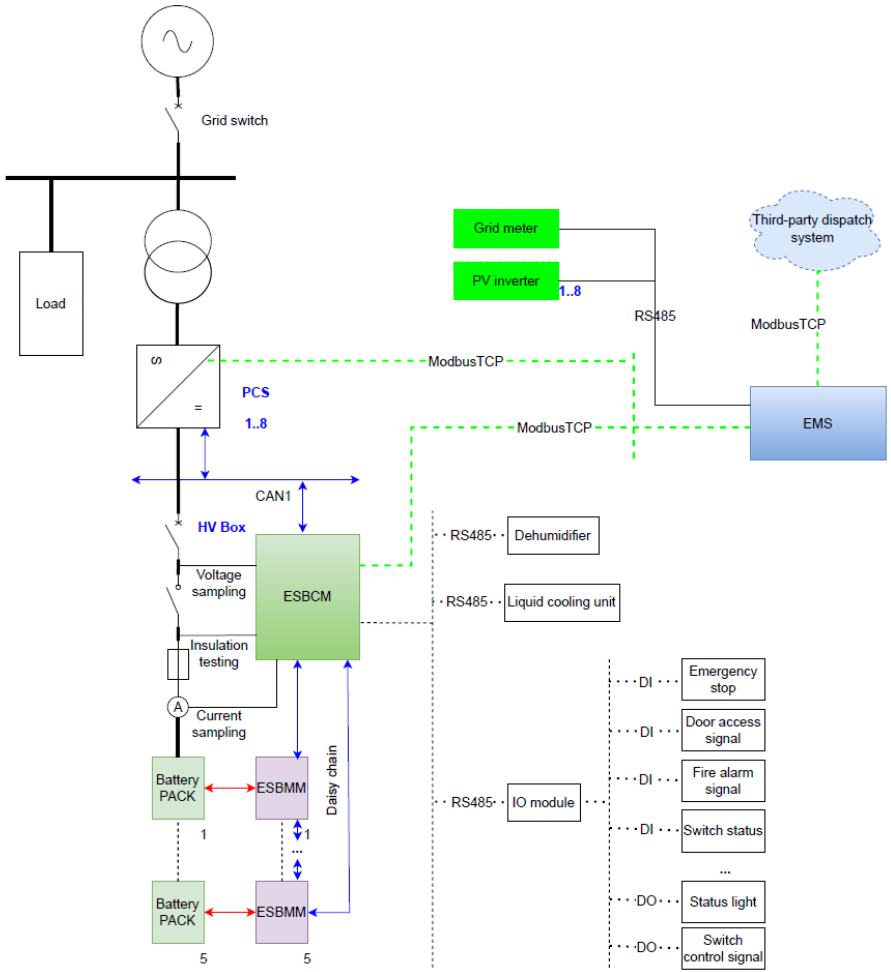

Figure 3-17 LEMS control system diagram

### 3.8.2 System Functions

This system is suitable for microgrid systems that include energy storage, PV, and loads (including critical loads and general loads). It has the functions of maximizing PV output, smoothing load demand peaks, peak-valley power dispatch, and preventing power backflow.

- Maximize PV Utilization

This LEMS can maximize PV power generation by monitoring the generation and consumption status in the microgrid. When the PV power generation in the microgrid exceeds the total load consumption, the LEMS can store the excess power in the ESS and release it when the microgrid load increases, achieving PV energy time-shifting and maximizing PV utilization.

- Smooth the peak load demand

LEMS can use energy storage to smooth internal load fluctuations. When the PV participates in output and the load power still exceeds the set demand limit, LEMS controls the energy storage output to smooth the excess demand, thereby improving the microgrid's economy.

- Power Limit

For microgrids that do not have surplus electricity to feed into the grid, this LEMS provides power limit control functionality. When it detects that the microgrid energy is below the power limit warning threshold, LEMS proactively adjusts energy storage and PV to avoid power limit, preventing the occurrence of power limit conditions.

- Used as a backup power supply for critical loads

When the system scheduling option of this LEMS is selected as backup, the LEMS ensures that the energy storage SOC is not lower than the backup SOC set by the system during operation, to ensure that important loads can be provided with backup power when the microgrid is off-grid.

- Peak shaving and valley filling

This LEMS can set strategies by time period, setting the PV energy time shift to fully charge the energy storage during the low electricity price period, and setting peak shaving and valley filling to release the energy storage power during the high electricity price period, thus achieving the function of peak shaving and valley filling.

- Microgrid status monitoring

This LEMS can access the control page by logging into the operation platform established on the local network, obtain the working status of PV and energy storage in real time, and perform off-grid and grid-connected switching. This LEMS can also send the basic information of operation to a third-party platform for data display.

### **3.8.3 Communication Connection**

- For pure storage applications, LEMS needs to be connected to the grid-connected meter (Modbus-RTU protocol), while LEMS, PCS, and BMS use Modbus-TCP protocol;
- For photovoltaic storage applications that require control of PV inverters, LEMS needs to be connected to the grid-connected meter and PV inverter (Modbus-RTU protocol);
- For pure off-grid applications, LEMS needs to be connected to the PV inverter;
- The energy storage system supports ModbusTCP protocol access to third-party scheduling & cloud platforms.

### 3.9 Grounding Wire

To reduce and eliminate electrical noise in the system and prevent the risk of electric shock, the system needs to be grounded. The grounding methods and requirements will vary depending on the specific project and system configuration. All grounding methods should comply with NEC Article 250.

The grounding wire should be at least 16mm<sup>2</sup>, with M8 or M10 ring terminals; specifications are as follows:

Table 3-9 Grounding wire specifications

Grounding wire Specification	Grounding screw	Screw specification	Screw hardness	Screw pitch	Screw material
16mm <sup>2</sup>	Cabinet grounding	M8*14L/ M10*30L	HRC32 Grade 8.8	1.25mm (0.05in)	SS304

Before leaving the factory, the electrical connections between the equipment inside the integrated cabinet have been completed. On-site, wiring is required between external equipment and the integrated cabinet, including grounding, AC power line wiring, and communication wiring. Grounding includes the equipotential connection inside the integrated cabinet and the grounding of the external grounding point of the compartment.

- Internal grounding:

Before leaving the factory, the equipotential connections between all equipment inside the integrated cabinet have been completed and uniformly summarized on the grounding copper bar.

- Compartment grounding

To facilitate on-site cable connection, the integrated cabinet is designed with a grounding point at the bottom inside the cabinet, as shown in the figure below. On-site, reliable connections should be made according to actual conditions. The grounding point of the C&I integrated cabinet can be grounded in the following way:

Use M8 bolts to connect the grounding cable to the external grounding point, and it is recommended to use a 35mm<sup>2</sup> cable.

Phase	Cable cross-sectional area	Bolt	Torque
GND	35mm <sup>2</sup>	M8	25 N·m

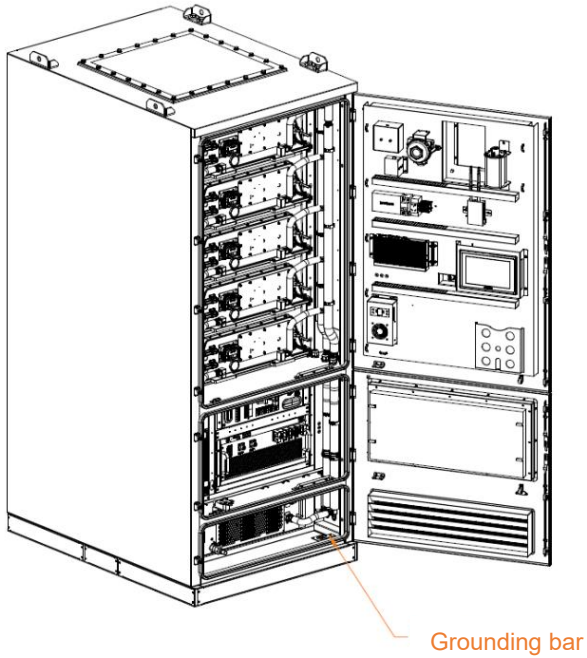
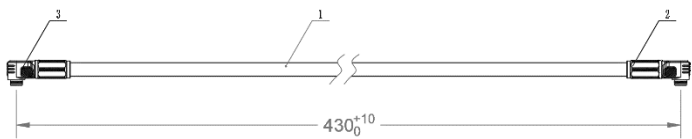
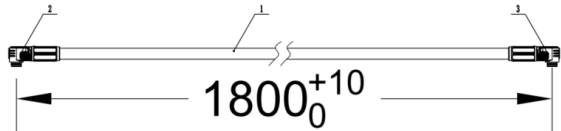
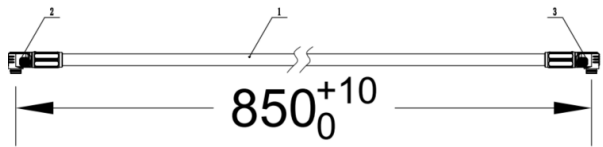

Figure 3-18 Grounding bar

### 3.10 Connection Cable between Battery PACKs

The connection cable is used to connect the battery PACKs in series to form a complete battery cluster, and finally connect to the high voltage box.

Table 3-10 Connection cable specifications

No.	Connection cable specifications
1	<p>Used for connection between upper and lower battery PACKs</p> 
2	<p>Used for connection from battery PACK total positive to high voltage box total positive</p> 
3	<p>Used for connection from battery PACK total negative to high voltage box total negative</p> 

## 4 Equipment Receiving and Installation

### 4.1 Personnel Requirements

All personnel engaged in installation activities should receive training on the Chint Commercial and Industrial (C&I) integrated cabinet system and possess relevant experience. Individuals should meet all training prerequisites and must complete system training. These personnel include:

- Service personnel performing any installation work within the owner's scope of work as specified in this document.
- Owner representatives performing any installation work within the owner's scope of work as identified in this document.

### 4.2 Personal Protective Equipment and Tools

---

#### Warning



- Do not wear watches, rings, jewelry, or other metal items.
- Wear a helmet correctly before entering the construction site to protect your head.
- Wear insulated gloves and safety shoes.
- Use well-insulated tools to prevent accidental electric shock or short circuits.

---

Before installation, the technical service engineer should prepare Personal Protective Equipment (PPE) and tools. As shown in the safety instructions earlier in this manual, basic PPE is required. Before performing any installation activities, check the condition of the personal protective equipment and confirm its availability.

The recommended tools and equipment are detailed in Annex 3 List of Tools. Ensure that all equipment is calibrated through approved calibration procedures and that the calibration is not expired. Due to the varying scope and scale of the projects, the types and quantities of required items should differ based on the actual situation.

## 4.3 Transportation and Delivery

### 4.3.1 Transportation Conditions

Refer to Annex 4 Installation and Debugging Instructions.

### 4.3.2 Hoisting

---

#### Warning



- During the entire process of lifting the integrated cabinet, it is necessary to strictly follow the safety operation procedures of the crane.
  - No one is allowed to stand within 10m of the operation area. Especially under the lifting arm and under the machine being lifted or moved, no one is allowed to stand to avoid casualties.
  - In case of severe weather conditions, such as heavy rain, thick fog, strong wind, etc., the lifting operation should be stopped.
- 

Before hoisting the integrated cabinet, please read and refer to the requirements in Annex 4 Installation and Debugging Instructions.

There are multiple scenarios for the installation layout of the integrated cabinet. The spacing requirements for each scenario are detailed in Annex 4 Installation and Debugging Instructions (Note: The reserved distance includes the tool operation space required for equipment replacement inside the cabinet and the thermal management spacing).

## 4.4 Installation Requirements

The integrated cabinet must be installed on a structure with a cement foundation or channel steel support surface. It is essential to ensure that the foundation is flat, solid, safe, reliable, and has sufficient load-bearing capacity. Any depression or tilting on the foundation surface is strictly prohibited.

The integrated cabinet can be welded to the foundation steel plate or connected by other methods with equivalent firmness.

For detailed specifications on the number of support points and the load-bearing capacity requirements of the support units for the integrated cabinet on the foundation, please refer to Annex 4 Installation and Debugging Instructions.

## 4.5 System Unpacking Inspection

### 4.5.1 Precautions

Before unpacking, to prevent the equipment from tipping over, please secure the box containing the equipment to the forklift with ropes before moving. Handle the equipment with care, as impact or dropping may cause damage.

During the packaging removal process, pay attention to tool usage to avoid scratching the equipment.

During the equipment packaging removal process, ensure the equipment remains stable and balanced, and take appropriate protective measures.

If the installation environment is poor, such as the presence of dust, corrosive gases, splashing water, and drastic temperature differences, etc., do not remove the packaging. If the packaging has been removed, please take dust-proof and anti-condensation measures (such as using dust covers, plastic films, or fabric covers) to avoid condensation or dust accumulation leading to corrosion and failure inside the battery.

After opening the packaging, please check the equipment surface for any obvious scratches, deformations, stains, or other abnormal damages, and notify the transportation provider or installer.

Daily maintenance and inspections should be properly recorded.

### 4.5.2 Safety Inspection

- The integrated cabinet involves high voltage and strong currents. Operation by anyone without professional supervision is prohibited. Operators must enhance their sense of safety and vigilance and always wear personal protective equipment (PPE), especially insulating gloves. The equipment must not be turned off or opened without authorization while it is running. In the event of an accident, quickly disconnect the main circuit breaker and ensure an immediate response is made to the responsible personnel.
- Pay attention to the weather conditions and enhance safety awareness during rainy days. Check the working environment where the integrated cabinet is located to ensure it is clean and tidy. Inspect whether the fire safety equipment is well-maintained and whether the escape routes are unobstructed.
- Ensure that the integrated cabinet has no insulation faults, and the insulation resistance of all busbars to ground is not less than 2.5MΩ as specified by national standards.
- Check the connection points of all wires to ensure they are secure. Specifically, refer to national standards and visually inspect the electrical safety clearance between the electrodes of the power lines, as detailed in the table below:

Table 4-1 Allowable values for electrical clearance and creepage distance

Rated line voltage / kV	Electrical clearance/mm	Creepage distance/ram
0.38 (0.4)	8	12 ( max )
0.66 (0.69)	10	20 ( max )
3 (3.5)	36	75 ( max )

Note: Refer to the standard UL 1973-2022.

### 4.5.3 Equipment Status Check

- Check whether the BMS display screen is normal, whether the total voltage of each battery cluster and the voltage of each battery cell are normal, and ensure that the BMS connection is normal.
- Check whether the equipment in the battery system is operating normally, and whether the power lines and communication lines of each BMS sub-unit are correctly connected.
- Check whether the fuses in the high voltage box are faulty and whether they are in normal condition. When all the relays in the high voltage box are in the open state, first set the DC side disconnecter to the open state.
- Check whether the liquid cooling unit is working properly. If there is a fault, refer to Annex 5 Alarm and Fault Handling Instructions for troubleshooting.
- Check whether the fire controller is working properly. If there is a fault, refer to the fire product manual for troubleshooting.
- Check whether there are foreign objects in the cooling axial fan.
- Confirm whether the DC power cable connections of each battery PACK are intact and whether the manual maintenance switch MSD is properly connected.
- During grid-connected operation, confirm that the knob switch SA is rotated to the AUTO position.
- Check whether the UPS display output voltage is normal and whether the frequency setting matches the project requirements.

### 4.5.4 Inspection Record

Each Chint Commercial and Industrial (C&I) integrated cabinet undergoes inspection and testing before leaving the factory. After the final installation of the integrated cabinet at the project site, the system should undergo another safety review before operation. To ensure the system continues to operate safely throughout its lifecycle, we need to conduct daily patrol inspections and record them.

## 5 Emergency Handling Procedure

### 5.1 First Aid Measures

Measures to be taken in case of leakage or spillage of substances such as electrolyte:

If electrolyte or other materials leak, immediately evacuate the area. Provide maximum ventilation, remove harmful objects or gases. Wipe clean with a cloth, dispose of it in a plastic bag, then place it in an iron can to allow the Battery to cool and the vapor to dissipate. Avoid skin and eye contact or inhalation of vapor, or use absorbent to remove spilled liquid and incinerate it. First aid measures for different parts are as follows:

- Eye first aid  
Rinse the eyes with plenty of water for at least 15 minutes, occasionally lifting the upper and lower eyelids, while seeking medical assistance.
- Skin first aid  
Remove contaminated clothing, rinse the skin with plenty of water or shower for 15 minutes, while seeking medical assistance.
- First Aid for Accidental Inhalation  
Immediately move from the leak area to a place with fresh air, and use oxygen if available.
- First Aid for Accidental Ingestion  
Immediately drink milk or water, induce vomiting, and seek medical attention immediately if the patient loses consciousness.

### 5.2 Fire Risk Assessment

#### 5.2.1 General Principles

Chint's principle is to protect everyone, including employees, customers, and contractors, from potential harm and health damage that may arise from work activities. Chint will provide and maintain a safe and healthy working environment, equipment, and work systems for all employees, and provide them with the

necessary information, training, and supervision for this purpose.

Chint will attach great importance to health and safety and comply with all statutory requirements.

### **5.2.2 Management System**

The fire safety system management plan is included in the "Health and Safety" document. It will confirm the completion of fire risk assessments to ensure adequate fire safety and will be reviewed as necessary.

Any deficiencies identified during the fire risk assessment process will be prioritized and corrected accordingly. Chint determines the safety protection and preventive measures for firefighting, and the customer is responsible for notifying the remaining responsible parties.

- Ensure these recommendations are implemented and communicated to other employees.
- Ensure coordination among the remaining responsible parties.
- Fire safety should be an agenda item in the weekly end-user manager meeting.

### **5.2.3 Overall Summary**

The equipment installed in this system mainly includes battery PACK, BMS, high voltage box (such as disconnecter, fuse, DC contactor, etc.), fire protection system, thermal management system, cabinet, cable, and PCS.

The fire resistance time of the integrated cabinet body meets the 60-minute fire protection requirement. The box is equipped with automatic detection, alarm, and aerosol fire extinguishing systems. The entire fire protection system meets the regulatory and certification requirements of the project site. A fire alarm is installed inside the integrated cabinet body, and the fire alarm can be immediately noticed when the cabinet door is opened or closed.

## 5.2.4 Classification of Fire Hazards

Table 5-1 Nature and types of fire source risks

No.	Fire risk	Detailed description	Corresponding measures
1	Internal short circuit	Dangers of low battery voltage, overheating, and battery swelling	The system is certified by UL 9540, and the rack is certified by IEC 62619, UL 1973, and EMC safety tests.
2	External fire source	If the temperature exceeds 130°C, there is a risk of battery failure and fire	The integrated cabinet body has a fireproof insulation layer, as long as the integrated cabinet is kept away from fire and heat sources.
3	External heat source		
4	External short circuit	During the installation process, or if the fuse is not installed properly, there may be risks of external short circuits, arc flashes, and fires.	Install the screws according to the manual and conduct a comprehensive inspection to ensure each one is tightened.
5	Loose screws	Causes excessive contact resistance, heating at the connection points and cables	
6	Overcharging	This situation only occurs when the system does not detect BMS faults, protections, parameter errors, or communication failures	The system complies with the UL1973 standard, has a dual protection system of software and hardware, and has low risk
7	Over-discharge		

## 5.2.5 Fire Risk Deduction

Consider from five aspects: component safety, battery cell safety, electrical safety (BMS), mechanical safety, and environmental safety.

- Component safety

Table 5-2 Components comply with IEC standards

No.	Component name	Compliance standard number
1	Plastic Components	IEC 60707
2	Fuse	IEC 60269
3	Relay	IEC 60947
4	BMS	IEC 60950
5	Anti-corrosion	IEC 60068

- Battery cell safety

Battery design complies with standards such as UL1642, IEC62133, UN38.3, etc.

- Electrical Safety

Table 5-3 Protection threshold (reference)

BMS function	Detailed description	Parameter
Single Cell Overcharge	Overcharge Voltage Protection Threshold	3.65V
	Overcharge Protection Delay Time	3s
Single cell over-discharge	Over-discharge voltage protection threshold	2.50V
	Over-discharge protection delay time	3s
	Discharge recovery voltage threshold	3.0V

Battery PACK overcharge	Overcharge Voltage Protection Threshold	189.8 V
	Overcharge Protection Delay Time	3s
	Overcharge recovery voltage threshold	182 V
Battery PACK over-discharge	Over-discharge voltage protection threshold	130 V
	Over-discharge protection delay time	3s
	Discharge recovery voltage threshold	156 V
Overcurrent protection	Discharge overcurrent protection delay time 1	5s
	Discharge overcurrent protection threshold	Refer to the alarm threshold table
	Discharge overcurrent protection delay time 2	500 ± 50ms
	Charge overcurrent protection	Refer to the alarm threshold table
Short circuit	Short circuit protection	-
	Protection conditions	Load short circuit
	Recovery conditions	Load disconnection
Over-temperature protection	Charging high temperature protection	55°C
	Charging temperature recovery	45°C

	Discharge high temperature protection	55°C
	Discharge temperature recovery	45°C
	Charging low temperature protection	0°C
	Charging temperature recovery	5°C
	Discharging low temperature protection	-20°C
	Discharge temperature recovery	0°C

Dual protection mechanism (see the figure below)

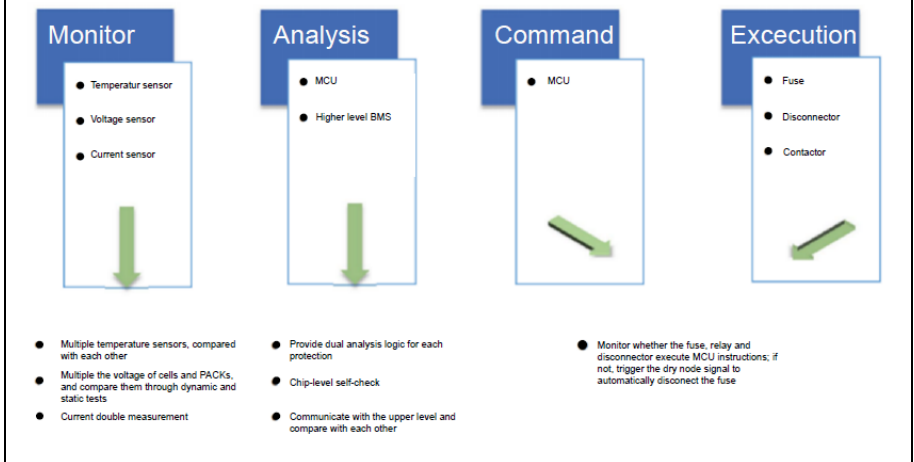

- **Mechanical Safety**

Complies with UN38.3 standard, passing tests such as static pressure, impact, drop, installation, etc.

- **Environmental Safety**

Preventive measures: temperature monitoring, UL94-V0 material, metal casing, safety valve design, BMS high-temperature protection, etc.

## 5.2.6 Fire Safety System

- Fire detection

"Smoke detectors" and "temperature detectors" are installed and connected to the "audible and visual alarm" via the "signal input/output module".

When the sensitivity of smoke exceeds 2.5%/m, or the temperature rises by more than 10°C per minute, the system may consider it a fire risk and will trigger the local alarm system "audible and visual alarm". At the same time, it will be reported to the background monitoring system for remote notification.

- Fire Alarm System

There is a manual/electrical fire alarm system, including automatic smoke detectors. When activated, it will warn all people near the integrated cabinet.

The cabinet is equipped with a fire alarm, and people near the integrated cabinet can immediately notice the fire alarm.

- Fire Extinguishing System

A sufficient number and correct types of fire extinguishers are arranged throughout the integrated cabinet system. They are sufficient to deal with the risks inside the integrated cabinet and are routinely inspected every 6 months.

The automatic fire suppression system (including gas extinguishing agent) compliant with NFPA 2001 will be automatically triggered.

The BMS will start protecting the system and cut off all power supplies; all fans and liquid cooling units will stop working to prevent fresh air from entering the container.

### 5.2.7 Identify Fire Hazards

- Ignition source

There are no obvious ignition sources in the entire integrated cabinet system environment, and smoking is prohibited near the integrated cabinet;

- Combustion fuel

No fuel, no large amount of paper; only some maintenance record paper.

- Work process

No process will cause serious fire hazard.

### 5.2.8 Flood and Water Disaster Risk Response

- Under the premise of ensuring personal safety, power off the system; for the system power-off operation procedure, please refer to Section 6 System Power On/Off Operation Procedures.
- If any part of the battery is submerged in water, do not touch the battery to avoid electric shock.
- Do not use batteries that have been flooded; contact a battery recycling company for disposal.

## 5.3 Emergency Measures

### 5.3.1 Emergency Measures Plan

Safe assembly point - specified by the end customer

Actions to be taken after discovering a fire:

- Use the nearest fire alarm call point to raise the alarm
- Report to the safe assembly point
- Call the fire brigade using a mobile phone (after leaving the integrated cabinet)
- Contact them after the fire brigade arrives
- Even if you are confident, do not attempt to handle small fires
- Do not put yourself in danger of fire

Actions to take after hearing the alarm:

- Gather at the safe assembly point
- Call the fire brigade with your mobile phone (after leaving the building)
- Contact them after the fire brigade arrives

Visitors:

- Ensure all visitors and contractors are escorted to the safe assembly point
- Assist any disabled persons with evacuation if necessary

The integrated cabinet must be installed on a concrete foundation or a structure supported by channel steel with a flame-retardant surface. The foundation must be flat, solid, safe, reliable, and have sufficient load-bearing capacity. It is strictly prohibited to have depressions or tilts on the foundation surface.

## 6 System Power On/Off Operation Procedures

### 6.1 Operational Procedures for C&I Integrated Cabinet

#### 6.1.1 Pre-power-on Inspection

Check whether the external connection cables and communication cables are completed, whether the MSD installation is finished, and whether there are any foreign objects around the cabinet, and ensure pre-power-on inspection is performed.

#### 6.1.2 Power-on Operation

1. Check the AC input, close the circuit breakers QF1\QF2\QF3\QF4 in sequence, and check whether the voltage is normal;

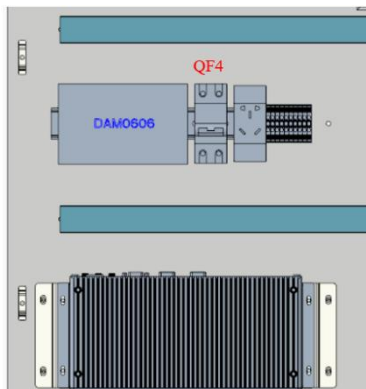
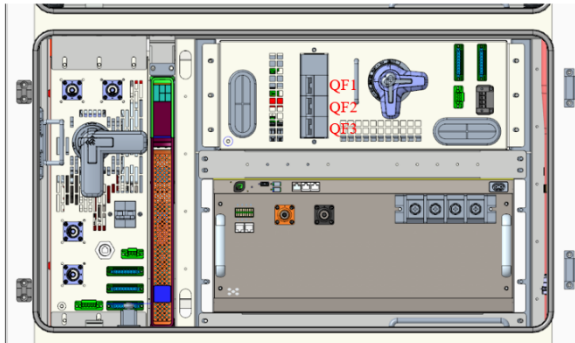

Figure 6-1 QF1\QF2\QF3\QF4

2. Press and hold the UPS power button for 3 seconds to power on the UPS, and check the output voltage AC220V on the UPS panel;



Figure 6-2 UPS

3. Close the disconnector QS (1) and the miniature circuit breaker QF (2) on the high voltage box, as shown in Figure 3-13:
4. Close molded case circuit breaker QF on the distribution box;

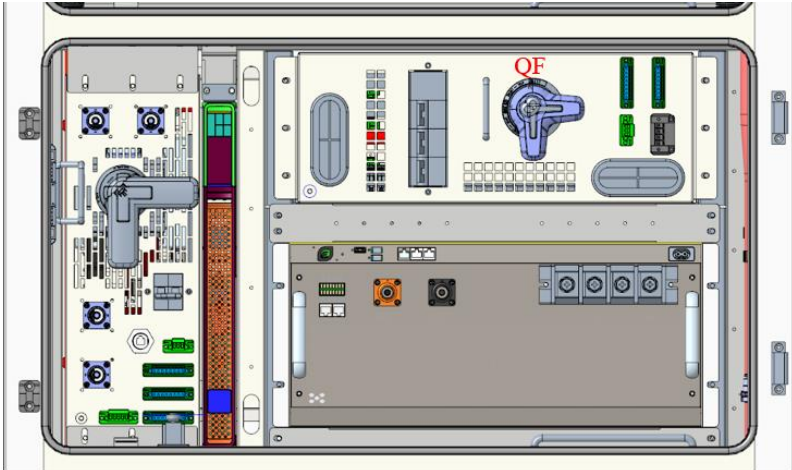

Figure 6-3 QF on the distribution box

### 6.1.3 Power-off Operation

1. Operate the LEMS system to issue a PCS shutdown command. Observe the PCS indicator light: if it flashes slowly (as shown by the red-circled indicator in the figure below), confirm that the PCS has successfully shut down.

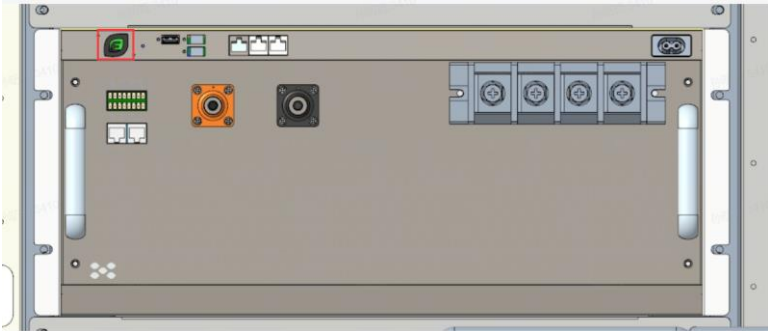

Figure 6-4 PCS panel diagram

2. Operate the LEMS system to issue a BMS power-off command, and confirm that the DC power-off operation is completed;
3. Manually disconnect the molded case circuit breaker QF in the distribution box;

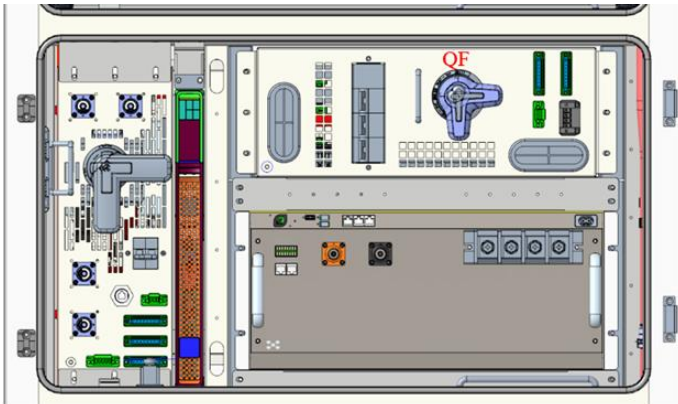

Figure 6-5 Manually disconnect the molded case circuit breaker QF

4. Long press UPS to shut it down. Confirm successful shutdown by verifying that all indicator lights on the display panel are extinguished.



Figure 6-6 Long press UPS to shut down

5. Disconnect the disconnecter QS (1) and miniature circuit breaker QF (2) on the high voltage box, as shown in Figure 3-13;
6. Manually disconnect the miniature circuit breakers QF1\QF2\QF3\QF4, as shown in Figure 6-1.

## 6.2 BMS System Operation Procedures

### 6.2.1 BMS System Architecture

Chint strongly recommends that the BMS be configured and commissioned by authorized factory representatives, otherwise it will not be covered by the warranty. ESMU can communicate with LEMS via ModbusTCP. ESMUs do not communicate with each other and should be treated as an independent subsystem. LEMS identifies different ESMUs by IP address. An example architecture is shown below:

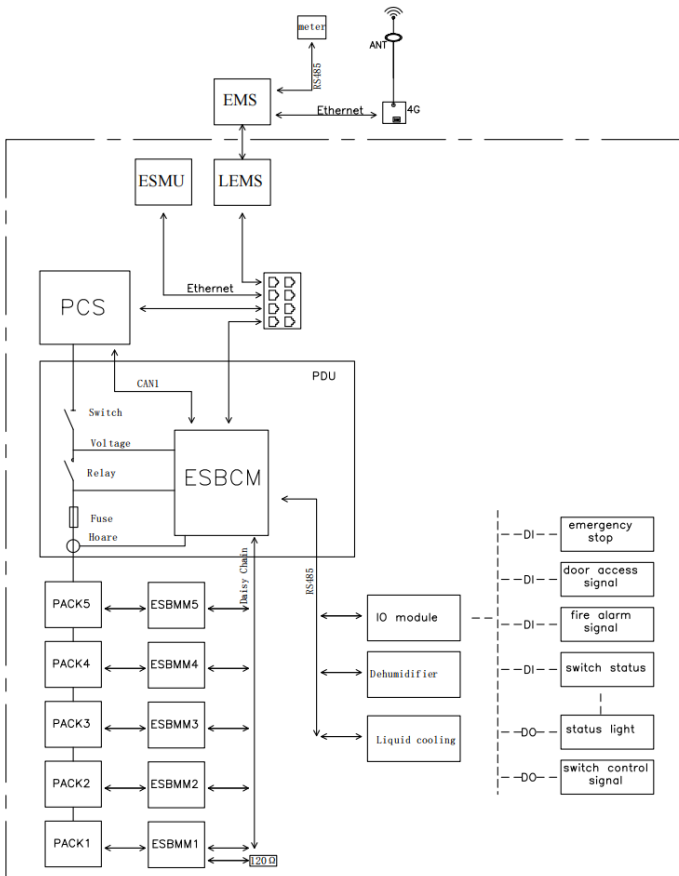

Figure 6-7 BMS system architecture diagram

## 6.2.2 System Configuration Preparation

Before system configuration, the following materials need to be prepared:

- Communication cable: for CAN / RS485 connection
- Adapter: matching high voltage box debugging port connector
- CAN box: USB to CAN tool for PC
- RS485 tool: USB to RS485 tool for PC
- Software: BMS host computer, CAN Test, serial port tools, etc.
- Standard network cable: Connect to ESMU to communicate with PC
- Laptop: Pre-installed with Windows 7 SP1 or a higher version of the operating system

## 6.2.3 BMS System Configuration

---

### Warning



- In the battery cluster, the ESBMM address will be automatically assigned without the need for separate configuration.
- When replacing the ESBMM, disconnect the AC power supply and circuit breaker of the high voltage box.
- After replacing the ESBMM, restore according to the normal power-on process.

---

#### 1. ID information of ESBMM

After the system is installed or the ESBMM is replaced, since the battery cluster adopts a daisy-chain communication method, there is no need to actively assign the address of the ESBMM.

#### 2. CAN data upload

As shown in the figure below, all ESBMMs communicate with ESBCM through a daisy-chain method. Each ESBMM has a unique ID on the battery cluster and has the function of address allocation.

ESBCM can collect data from all ESBMMs, and ESBMMs can also update data and send warnings to ESBCM via the daisy-chain.

ESBCM communicates with the master ESMU through LAN data.

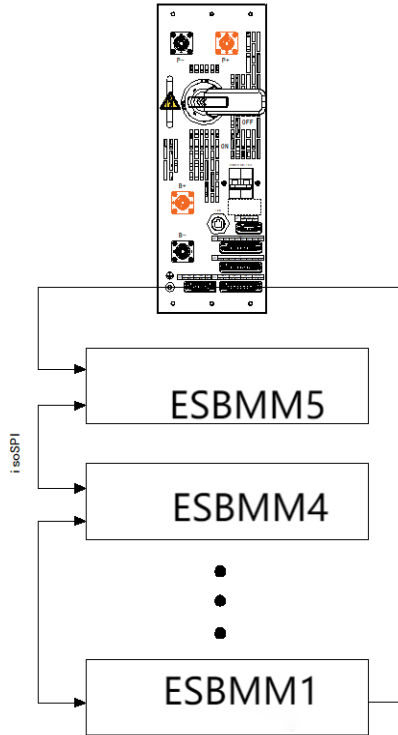

Figure 6-8 Communication architecture between ESBMM and ESBCM

3. Software online upgrade

The internal software logic of ESBMM is implemented by ESBCM, and no software upgrade is required. For updates that may involve BMS, BMS can upgrade all ESBCM software through CAN communication. The software upgrade can be easily completed by importing the latest program through ESMU.

## 6.2.4 ESMU Configuration

The system automatically enters the main interface upon startup, which displays information such as the total voltage and total current of the battery system, as well as the voltage value, current value, SOC value, and working status of the battery cluster.

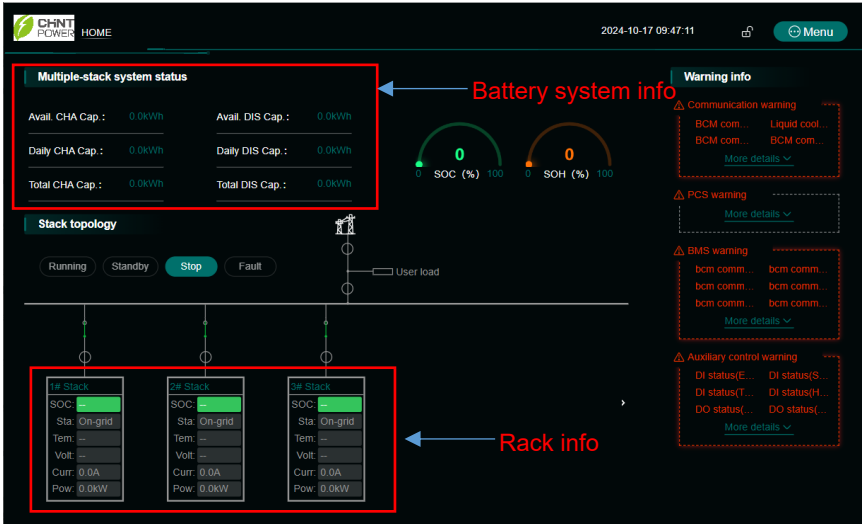

Figure 6-9 Main interface

Click the icon of the battery cluster in the main interface to display detailed information of the battery cluster, including voltage, current, SOC, SOH, charge/discharge capacity, maximum and minimum voltage and temperature of the battery cells, and other key information.

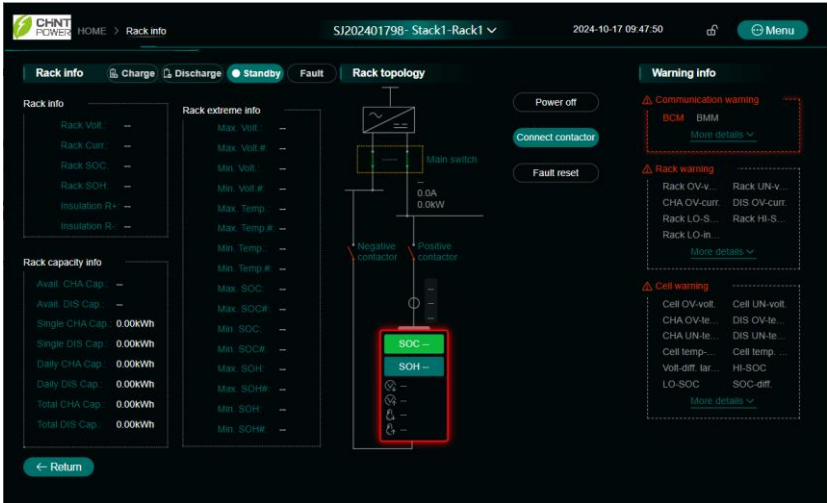

Figure 6-10 Battery cluster parameters (reference)

Click the icon of the battery PACK in the above figure to display the voltage of each battery PACK, the temperature at each position, warning/fault information, etc.

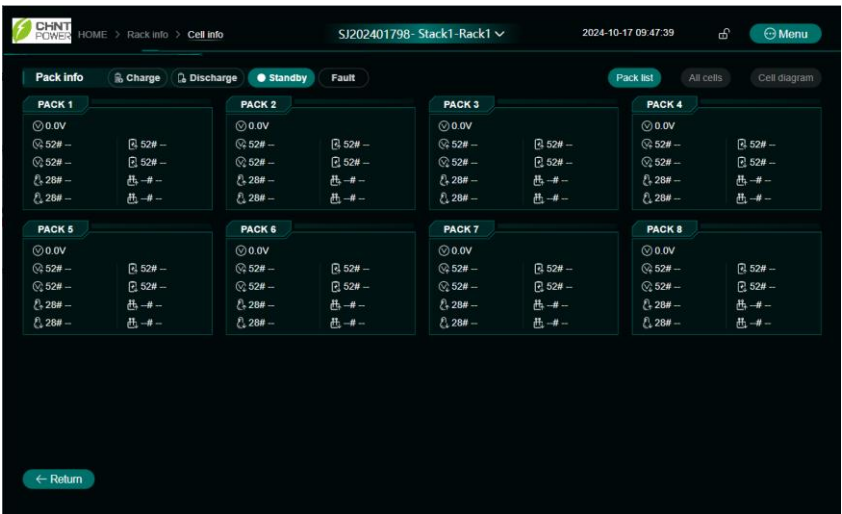

Figure 6-11 Battery PACK parameters (reference)

## 6.2.5 Network Port Configuration

After installation, wiring, and configuration, connect the Ethernet cable to the ESMU, communicate via MODBUS, and check if the system BMS provides correct data.

The default IP addresses are: LAN0: 10.122.1.88, LAN2: 195.16.19.88.

Port Number: 502

## 6.2.6 Typical Protection Strategy

The basic protection strategy is outlined as follows (may vary according to the specific requirements of the application):

- Source of protection signals
  - Module/unit information based on BMS analysis and alarm triggering
  - BMS hardware failure
  - Communication issues within the BMS or with the LEMS/PCS
  - The BMS sends signals to the PCS/LEMS via Modbus
- The LEMS/PCS shuts down the inverter
- If the inverter does not shut down within 3-5 seconds, the BMS activates a hardwired signal to shut down the inverter
- If the inverter does not shut down after 5 seconds, the BMS disconnects the battery by opening the contactor

## 6.3 PCS Operation Procedures

For details, please refer to the PCS user manual.

## 6.4 LEMS Operation Procedures

For details, please refer to the LEMS user manual.

---

## 7 Troubleshooting

---

### Note



- The integrated cabinet is a high voltage DC system and can only be operated by qualified and authorized personnel!
- Before checking for faults, it is necessary to check whether all cable connections and settings of the PCS and BMS are correct, and whether the integrated cabinet can be powered on normally.

---

Common system product failures involve the following equipment: BMS, battery PACK and cables, liquid cooling unit and pipelines, PCS, and dehumidifier. For detailed fault causes and troubleshooting of each equipment, please refer to Annex 5 for fault and alarm handling instructions.

---

## 8 Performance Maintenance

---

### Note



- Operation and maintenance of battery PACK, liquid cooling unit, fire protection systems, and other related equipment must be performed by qualified and authorized personnel.
- Some maintenance tasks require the system to be shut down beforehand.

---

Both scenarios of system operation exceeding six months or prolonged downtime require safety maintenance and proper documentation. Specific items are as follows:

1. Check whether the safety door, front door, and battery cabinet door of the integrated cabinet can be opened normally, and ensure that the environment inside and outside the integrated cabinet is clean and tidy;
2. Check whether the fire extinguishing system can alarm and start normally, and whether there are firefighting equipment around the integrated cabinet for emergency use in case of an accident;
3. Check whether the insulation of each power line is abnormal, whether the electrical safety gap meets the safety standards, and whether the wiring bolts are loose;
4. Check whether the electrical components are normal, and whether the power doors of each power supply can be effectively disconnected;
5. Detailed maintenance requirements for each device, please refer to Annex 6 System Maintenance Instructions for details.

## 9 Quality Assurance

### 9.1 Liability Exemption

1. Exceed the quality assurance period of the product.
2. Cannot provide product serial number or the SN is not clear/complete.
3. Damage during transportation/storage/handling.
4. Misuse, abuse, intentional damage, negligence, or accidental damage.
5. Improper commissioning, testing, operation, maintenance or installation performed by customer, including but not limited to:
  - Failure to meet safe operating environment or system requirements of external electrical parameters provided in written document;
  - Failure to operate the covered product in accordance with the product's operating manual or user guide;
  - Relocate and reinstall systems not in accordance with the requirements of Chint power;
  - Unsafe electrical or chemical environment or other similar kind of conditions;
  - Direct failure caused by wrong voltage or faulty power system;
  - Unauthorized disassembly of the products, or unauthorized modification of the product or provided software.
6. Entrust installation, maintenance personnel not designated by the CHINT to install, repair and disassemble the products.
7. Damages caused by ignoring the safety warnings in the manual or break the rules in relevant statutory safety regulations.
8. Damages caused by operating environment beyond the requirements of the product user manual or failure to commissioning, install, use and maintain the equipment according to the requirements of the product user manual.
9. Unforeseen disasters or irresistible accidents (including but not limited to acts of public enemies, acts of government agencies or domestic or foreign institutions, vandalism, riots, fires, floods, typhoons, explosions or other

- disasters, epidemic or quarantine restrictions, labor disturbances or labor shortages, accidents, cargo embargoes or any other events beyond the control of CHINT).
10. The lightning protection measures have not been implemented or are not in accordance with standards (Photovoltaic systems' lightning protection measures should comply with the relevant national and IEC standards; otherwise, it may result in damage to photovoltaic devices such as modules, inverters, distribution facilities, etc., due to lightning strikes).
  11. Other circumstances that are not covered by the company's after-sales warranty agreement.
  12. Equipment failure or software damage caused by using non-standard components/accessories, connection of incompatible configurations (such as batteries, etc.) or other brand products or accessories without permission, improper configuration selection/storage/use.

## **9.2 Quality Terms (Warranty Terms)**

1. For products that fail during the warranty period, our company will repair or replace new products free of charge.
2. Customer shall present the invoice of the product and date of purchase. At the same time, the trademark on the product should be clearly visible, otherwise we have rights to refuse quality assurance.
3. The unqualified product under replacement should be returned to our company.
4. It is necessary to provide a reasonable time for the company to overhaul the equipment.
5. For more warranty terms, refer to the applicable standard warranty policy in place at time of purchase.





## Annex 1 Safety Training Records

Customer Name		Training Location	
Training Purpose		Contact Number	
Trainer		Training Time	
Training Content			
Basic Requirements	<ul style="list-style-type: none"> <li>• Before entering the site, it is necessary to wear labor protection equipment.</li> <li>• On-site installation personnel are not allowed to use metal accessories (watches, necklaces).</li> <li>• Special types of construction projects must be carried out by certified personnel within their scope of work.</li> </ul>		
Battery PACK Handling	<ul style="list-style-type: none"> <li>• Short circuits are strictly prohibited.</li> <li>• It is prohibited to use steel wire ropes as transportation tools.</li> <li>• Do not forcibly pull the terminals of the battery PACK.</li> <li>• Handle with care, avoid strong impacts and vibrations, do not invert, do not throw, and avoid exposure to sun and rain.</li> </ul>		
Battery PACK Installation	<ul style="list-style-type: none"> <li>• Inspect the appearance of each battery PACK to promptly identify any defects.</li> <li>• Strictly follow the supervisor's instructions to place the battery PACK, paying attention to the terminal positions.</li> <li>• Handle with care to ensure personal safety and avoid damaging the battery.</li> </ul>		
Battery PACK Connection	<ul style="list-style-type: none"> <li>• Insulate metal tools such as wrenches to prevent short circuits in case of dropping.</li> <li>• The supervisor should strictly monitor the battery PACK connection to avoid short circuits.</li> <li>• Ensure all bolts on the battery PACK are tightened.</li> </ul>		

Overall	<ul style="list-style-type: none"><li>• Protective covers should be installed on the cables in a timely manner.</li><li>• Clear markings are required: powered equipment</li><li>• There should be no construction work around the battery PACK; if unavoidable, wrap the battery PACK with insulating plastic sheeting before construction, and do not damage the battery PACK.</li></ul>
Signature	
If all the above requirements can be met, please sign below:	





Note: If an accident is caused by improper operation, our company will not bear any responsibility.

## Annex 2 Personal Protective Equipment List



No.	Category	Sample	Requirements
1	Safety Helmet		Before entering the construction site, the helmet should be used correctly to protect the head; The helmet should meet the requirements of ANSI Z89.1 "Industrial Safety Helmets"
2	Electrician's Clothing		Field service personnel need to wear electrician uniforms
3	Protective shoes		During the transportation and installation of battery PACK, protective shoes must be worn; Field service personnel need to wear protective shoes
4	Insulating gloves		On-site maintenance personnel need to wear insulated gloves
5	Mask		On-site service personnel need to wear masks

Note: Other types of PPE and corresponding quantities are determined by on-site requirements.

### Annex 3 List of Tools

No.	Name	Material	Specification	Sample	Qty.	Remarks	Calibration date	Validity Period
1	Laptop				2	Important Tool		
2	Tape Measure	Steel	5 m		1	Important Tool		
3	Wrench (insulated)	Stainless steel	1 complete set		1	Important Tool		
4	Socket wrench (insulated)	Stainless steel	1 complete set		1	Important Tool		

No.	Name	Material	Specification	Sample	Qty.	Remarks	Calibration date	Validity Period
5	Insulated torque wrench	Stainless steel	1 complete set		2	Important Tool		
6	Screwdriver	Stainless steel	1 complete set		1	Important Tool		
7	Gradient meter (level)	Aluminum alloy	1000mm		1	Important Tool		
8	Electric wrench				1	Important Tool		
9	Electric drill				1	Important Tool		

No.	Name	Material	Specification	Sample	Qty.	Remarks	Calibration date	Validity Period
10	Multimeter				1	Important Tool		
11	Battery tester		HIOKI 3564		1	Important Tool		
12	Forklift				1	Important Tool		

## Annex 4 Installation and Debugging Instructions

### Annex 4.1 Preparations Before System Installation

Specific personnel requirements, Personal Protective Equipment (PPE), and tools can be referred to in Chapter 4 Equipment Receiving and Installation.

#### Annex 4.1.1 Transportation and Delivery

##### Annex 4.1.1.1 Transportation Conditions

The internal equipment of the integrated cabinet has been installed and fixed before leaving the factory, allowing for whole machine transportation. The lifting method is as follows: use a crane to lift and transport the integrated cabinet;

The integrated cabinet is transported to the power station site by a freight company, and the on-site power station management personnel will be contacted in advance to negotiate and arrange specific delivery and unloading. The transportation after delivery and unloading needs to be completed by the on-site power station construction personnel.

---

#### Warning



During the transportation and handling of the integrated cabinet, it is necessary to comply with the operational safety regulations of the country/region where the project is located.

- All equipment used during transportation needs to be maintained.
- All personnel involved in handling and securing should receive appropriate training, especially in safety.

---

#### Note



Always keep in mind the mechanical parameters of the integrated cabinet during transportation and handling:

- Width x Depth x Height: 1000\*1416\*2415mm
- Gross weight: approximately 2535kg

---

Transporting and moving the integrated cabinet should at least meet the following conditions:

- All doors of the integrated cabinet are tightly locked.

- According to the site conditions, choose the appropriate transportation tool, usually a crane. The transportation tool used must have sufficient load-bearing capacity.
- If it is necessary to move on a slope, etc., additional traction devices may be required.
- Remove all obstacles that exist or may exist during the moving process, such as trees, cables, etc.
- The transportation and moving of the integrated cabinet should be carried out under favorable weather conditions as much as possible.
- Warning signs or caution tapes must be set up to prevent non-staff from entering the lifting and transportation area to avoid accidents.
- In addition, when the integrated cabinet is grounded, the following should also be ensured:
  - When landing, pay attention to gently placing it. Do not drag or push the integrated cabinet on any surface.
  - The integrated cabinet should be placed on a solid, flat, well-drained ground free of obstacles and protrusions, and the integrated cabinet should only be supported by its base.

---

### Annex 4.1.1.2 Hoisting

---

#### Warning



- During the entire process of lifting the integrated cabinet, it is necessary to strictly follow the safety operation procedures of the crane.
- No one is allowed to stand within 10m of the operation area. Especially under the lifting arm and under the machine being lifted or moved, no one is allowed to stand to avoid casualties.
- In case of severe weather conditions, such as heavy rain, thick fog, strong winds, etc., hoisting operations should be stopped.

---

When lifting the integrated cabinet, at least the following requirements must be met:

- Safety on site must be ensured during lifting.
- During lifting and installation operations, a professional should be present to supervise the entire process.
- The lifting tools, lifting angle, and lifting speed are detailed in the lifting diagram below.
- The crane should have sufficient boom length and rotation radius.
- Ensure that all sling connections are secure and reliable, and ensure that each section of the sling connected to the lifting ring is of equal length.
- The length of the sling can be appropriately adjusted according to the actual requirements on site.
- Throughout the lifting process, it is essential to ensure that the integrated cabinet remains stable and does not tilt.
- Please use the four lifting rings of the integrated cabinet to perform the lifting operation of the integrated cabinet.
- Take all necessary auxiliary measures to ensure the safe and smooth lifting of the integrated cabinet.

The following figure shows the crane operation during the lifting process of the integrated cabinet. In the figure, the inner circle (Circle A) represents the crane

operation range. When the crane is working, standing inside the outer circle (Circle B) is strictly prohibited!

The radius of Circle B is  $\geq 10$  meters.

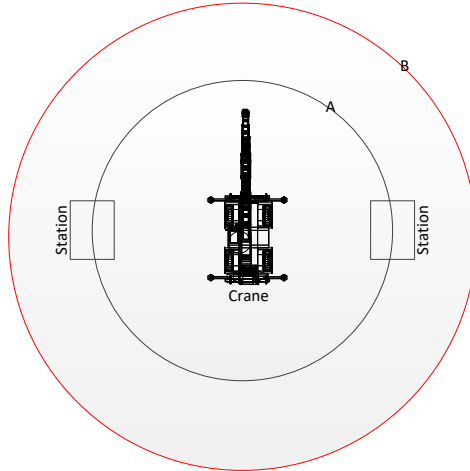

Figure Annex 4- 1 Lift the integrated cabinet

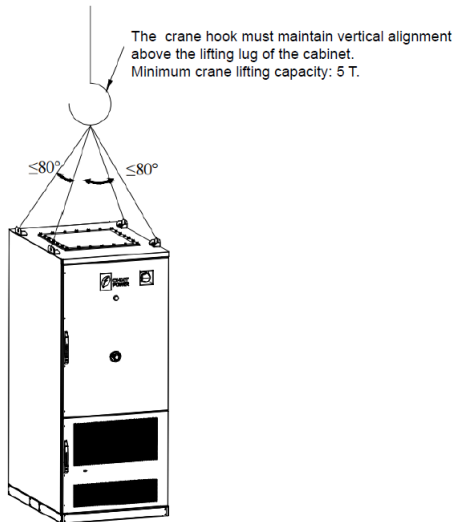

Figure Annex 4- 2 Hoisting

**Technical Requirements:**

- Recommended hoisting plan: Slanted hoisting at the hoisting points, with the hoisting tool more than 1 meter away from the top of the cabinet.
- The force applied by the hoisting rope to the hoisting points of the cabinet, and the angle between the ropes should be less than or equal to  $80^{\circ}$  .
- Hoisting speed  $\leq 5$  meters/minute.
- During hoisting, the cabinet should be well protected, especially at the points where the lifting rope contacts the cabinet.
- The maximum external dimensions of the cabinet:  
1000mmx1416mmx2500mm (the height includes the dimensions with the lifting rings).
- The estimated total weight of the cabinet:  $2535 \pm 50$ kg.
- The lifting equipment and ropes should be considered with sufficient safety factors by a professional hoisting company.

The layout of the liquid-cooled Commercial and Industrial (C&I) cabinet includes the following scenarios, and the spacing requirements for each scenario are as follows (Note: the reserved distance includes the tools required for equipment replacement inside the cabinet and thermal management):

Scenario 1:

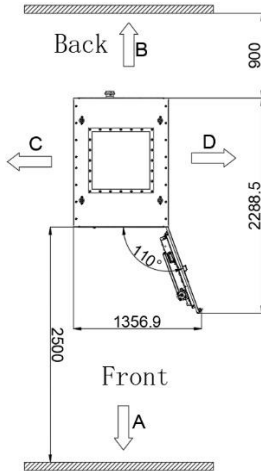

Figure Annex 4- 3 Layout scenario 1

Scenario 2:

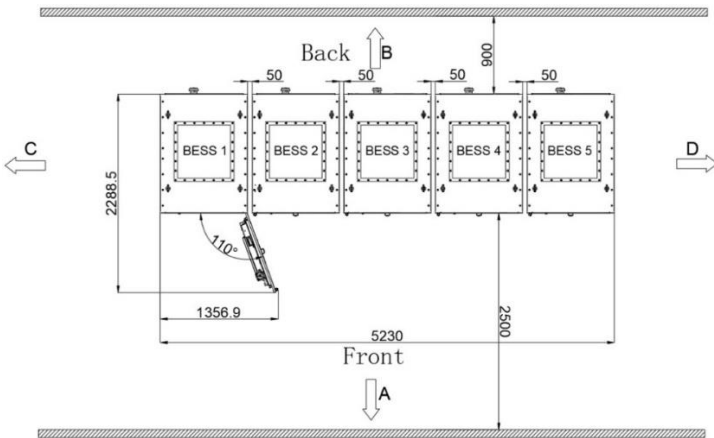

Figure Annex 4- 4 Layout scenario 2

Scenario 3:

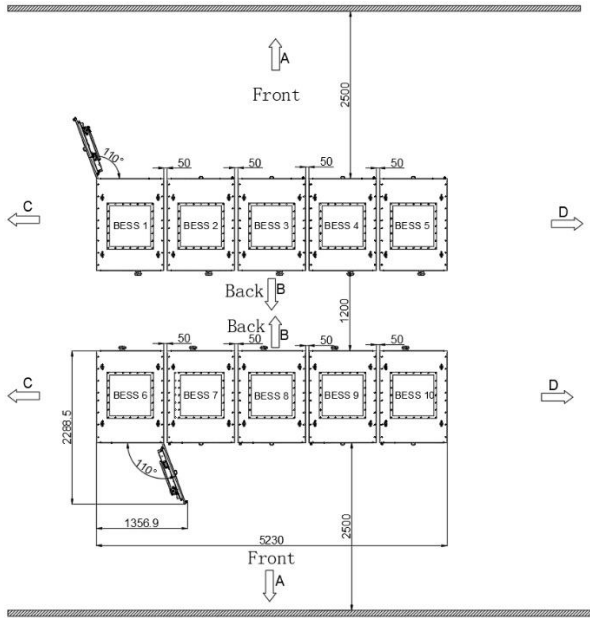

Figure Annex 4- 5 Layout scenario 3

Scenario 4:

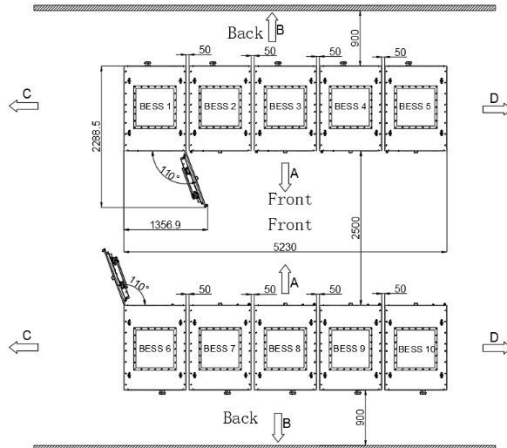

Figure Annex 4- 6 Layout scenario 4

### Annex 4.1.2 Installation Requirements for Integrated Cabinet

The integrated cabinet must be installed on a structure with a cement foundation or channel steel support surface. It is essential to ensure that the foundation is flat, solid, safe, reliable, and has sufficient load-bearing capacity. Any depression or tilting on the foundation surface is strictly prohibited.

The integrated cabinet can be welded to the foundation steel plate or connected by other methods with equivalent firmness.

The number of support points and the load-bearing capacity of the support units for the integrated cabinet on the foundation are shown in the following figure:

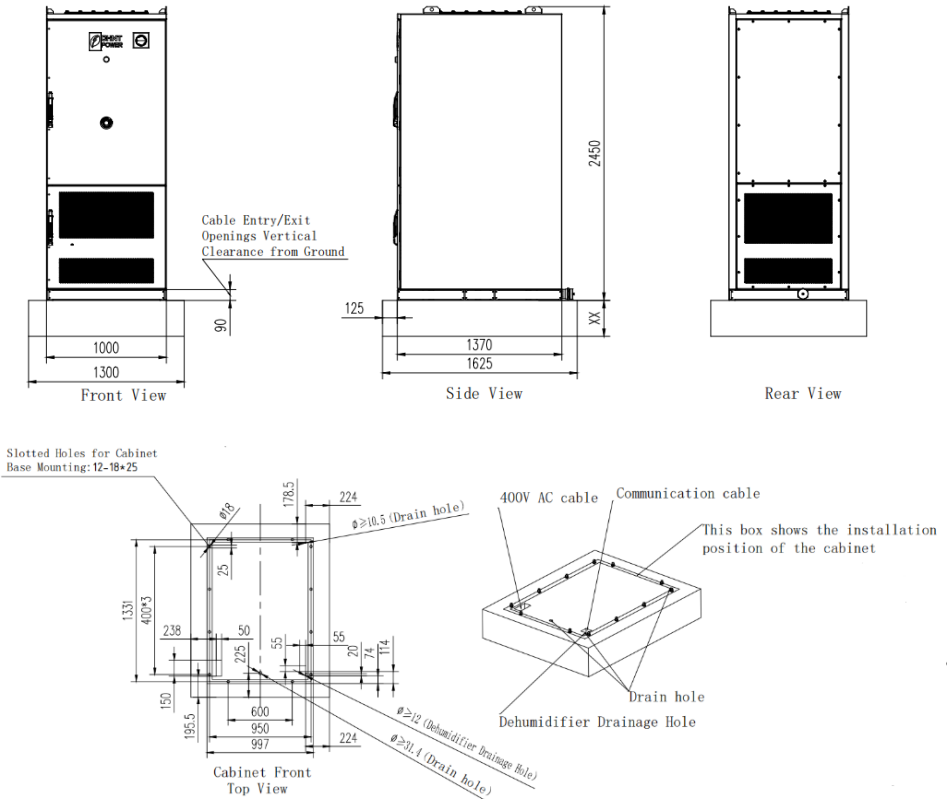

Figure Annex 4- 7 Support point

**Technical Notes:**

- This drawing is for reference only and is intended to be used as a reference for customers to design the foundation. It cannot be used as a foundation construction drawing.
- The foundation reference plane of the integrated cabinet needs to be above the horizon and higher than the maximum precipitation height at the project site.
- The maximum total weight of the integrated cabinet is approximately 3 tons. It is recommended that the minimum support weight of the foundation exceeds twice the total weight of the integrated cabinet.
- The reference plane of the entire foundation shall be controlled within  $\pm 2\text{mm}$  flatness; if the foundation flatness exceeds this requirement, after the integrated cabinet is fully loaded with battery PACKs, it may cause the cabinet door to fail to open and close normally, or even result in permanent deformation that cannot be repaired. Please strictly follow this requirement.
- When arranging multiple cabinets, it is recommended to reserve 50mm between cabinets for convenient on-site cabinet installation.

**Annex 4.1.3 System Inspection**

Refer to Section 4.5 System Unpacking Inspection for details.

**Annex 4.2 System Operation and Debugging Procedures****Annex 4.2.1 Operational Procedures for C&I Integrated Cabinet**

For specific operating procedures, please refer to 6.1 Operational Procedures for C&I Integrated Cabinet.

**Annex 4.2.2 BMS System Operation Procedures**

For specific BMS system operating procedures, please refer to 6.2 BMS System Operation Procedures.

## Annex 4.2.3 PCS Operation Procedures

For specific operating procedures, please refer to 6.3 PCS Operation Procedures.

## Annex 4.2.4 Battery Replacement

### Note



- This Battery system is a high voltage DC system and can only be operated by qualified authorized personnel.
- Before replacing major components, the main circuit of the maintenance battery cluster must be disconnected first. All component repairs and replacements can only be performed by qualified personnel, and only approved materials, components, and parts can be used for replacement.

### Annex 4.2.4.1 Disassemble Battery PACK

1. Disconnect the DC side of the PCS (disconnect the disconnecter), turn off the BMS system, and ensure the high voltage box is in the disconnected state;

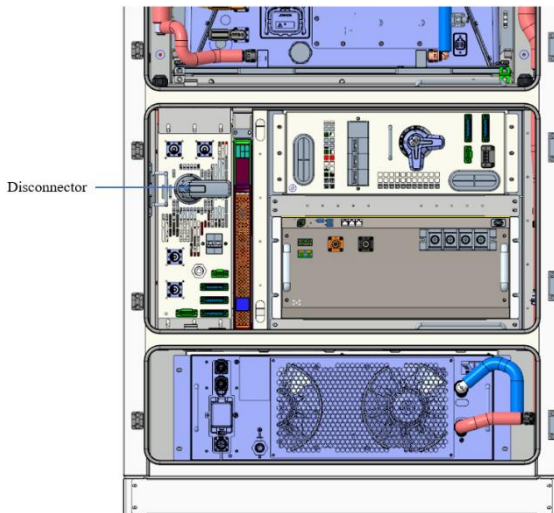

Figure Annex 4- 8 Disconnecter

2. Locate the faulty battery PACK and pull out the MSD (4);

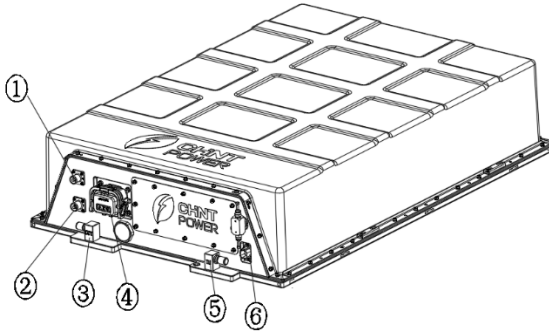

Figure Annex 4- 9 MSD

3. Disconnect the cables (cable 1#, 2#, 3#);

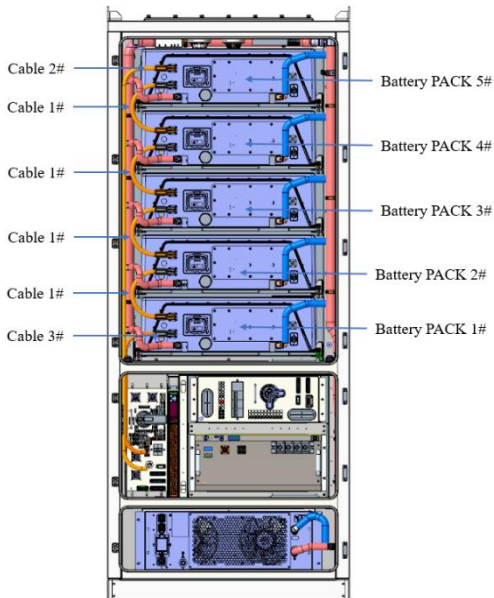

Figure Annex 4- 10 Disconnect the cable

4. Remove the communication cable;

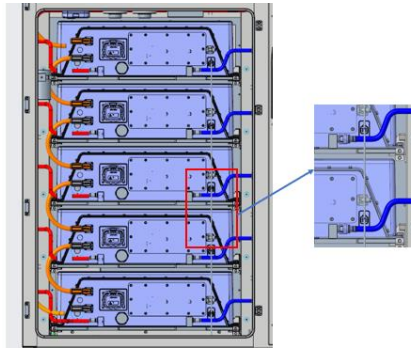

Figure Annex 4- 11 Remove the communication cable

5. Close the liquid cooling pipeline valve (1);

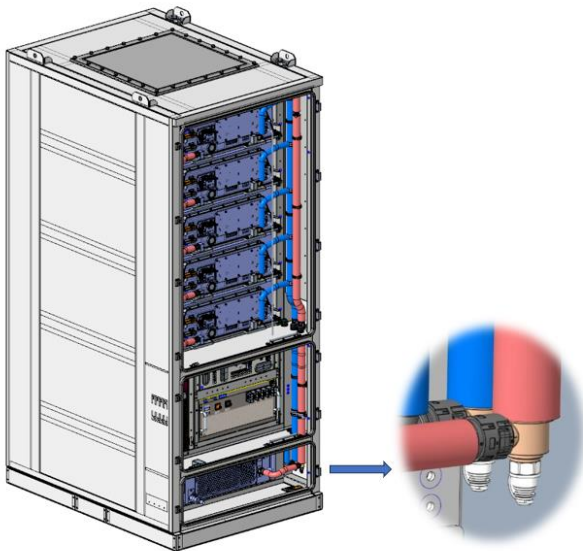

Figure Annex 4- 12 Close liquid cooling pipeline valve

6. Remove the coolant inlet/outlet pipelines (1,2), and drain the remaining coolant in the pipelines, and place the disassembled parts in the designated location;

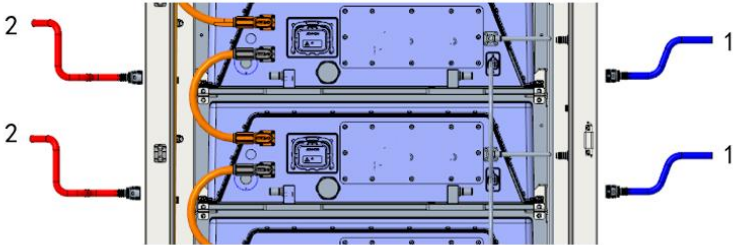

Figure Annex 4- 13 Remove the coolant pipeline

7. Remove the 4 screws fixed on the side beam of the battery rack and keep them properly, as shown in the red box in the figure below:

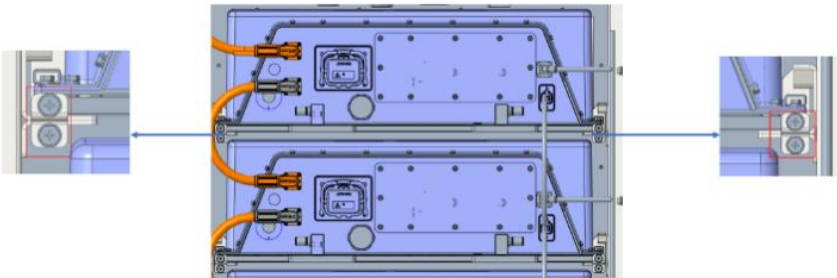

Figure Annex 4- 14 Remove the screws

8. Pull the battery PACK out of the battery rack: Fix it on the threaded hole of the side beam of the battery PACK with a hand ring or a special tool as shown in the figure, and pull it out about 50cm. During the handling process, please pay attention to personnel protection to prevent personnel from falling or the battery PACK from falling.

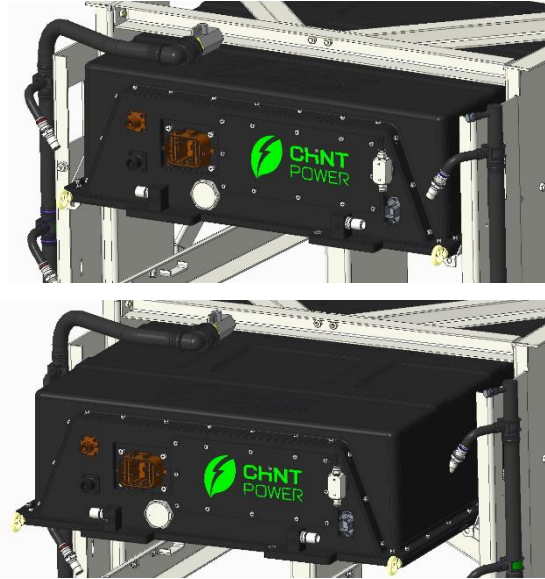

Figure Annex 4- 15 Remove the battery

- Place the battery on the lifting tool: Move the specialized forklift with a wheeled workbench or platform to the bottom of the target battery PACK, move the battery PACK onto the platform, and pull the battery PACK completely out of the rack.

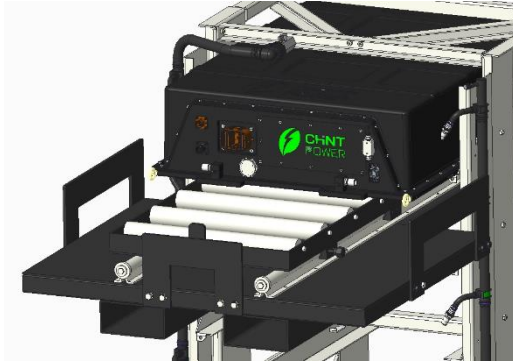

Figure Annex 4- 16 Place the battery PACK on the lifting tool



Figure Annex 4- 17 Forklift

---

**Annex 4.2.4.2 Install the Battery PACK**

---

**Instructions**

Before installation, please carefully read the following precautions.

---

- Before installing the new battery PACK, please confirm whether the battery PACK capacity matches the system: if it matches, replace it directly; if it does not match, consult a battery engineer.
- The disconnect handle of the high voltage box should be in the "OFF" state
- After the new battery PACK is installed, the system needs to be powered on, and then the status information of the target battery PACK should be confirmed through the display control interface to confirm whether the fault has been recovered or to proceed to the next step. If there are other abnormal information, please contact professionals or the manufacturer for handling.

Refer to the operation requirements in Annex 4.2.4 Battery Replacement to install the Battery on the Battery rack. There is no distinction between battery PACKs A and B, that is, the positive (+) and negative (-) terminals are identical in configuration. The Battery arrangement sequence is shown in the following figure:

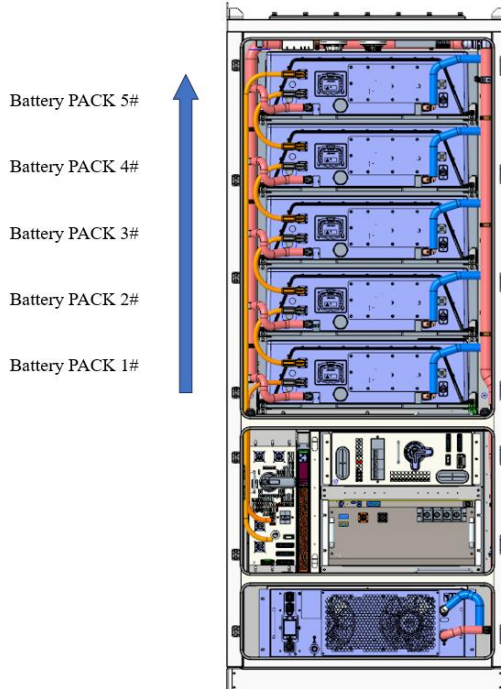

Figure Annex 4- 18 Battery PACK sequence

### Annex 4.2.4.3 Power Cable Installation

#### Warning

- Please operate with caution to avoid short circuits between the positive and negative terminals of the battery PACK.
- Be extremely careful to prevent the positive and negative terminals from coming into contact with any location other than the predetermined installation point.
- When installing cables, only connect the positive and negative terminals corresponding to the two battery PACKs first.
- After the power cables for each battery PACK are installed, check whether the cable connectors are properly inserted.
- Ensure that the high voltage box disconnecter is in the "OFF" position.
- Ensure that there is no 24VDC auxiliary control power input to the high voltage box.



After connecting the cables between the battery PACKs and between the battery PACK and the high voltage box, the entire battery cluster forms a complete circuit. The cable installation steps are shown in the following figure:

1. Ensure that the high voltage box disconnecter is in the "OFF" state. Then, connect the B+ and B- terminals of the high voltage box to the B+ and B- terminals of battery PACK 1. After the cables are connected, ensure that the connectors at both ends are properly inserted.

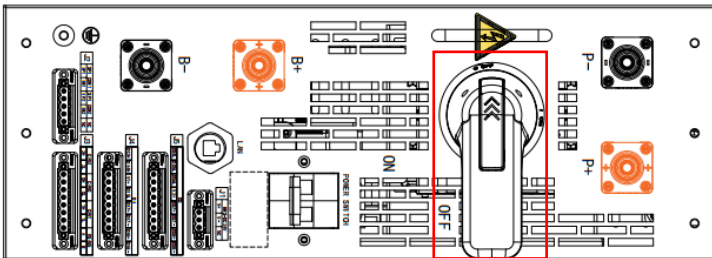

Figure Annex 4- 19 Disconnector of high voltage box in the "OFF" position

2. Use the total negative connection harness of the battery PACK and the high voltage box, and insert the harness plug into the negative socket of battery PACK 1# and the B- socket of the high voltage box (the color matches the plug). When you hear a "click," it means the plug is properly inserted.

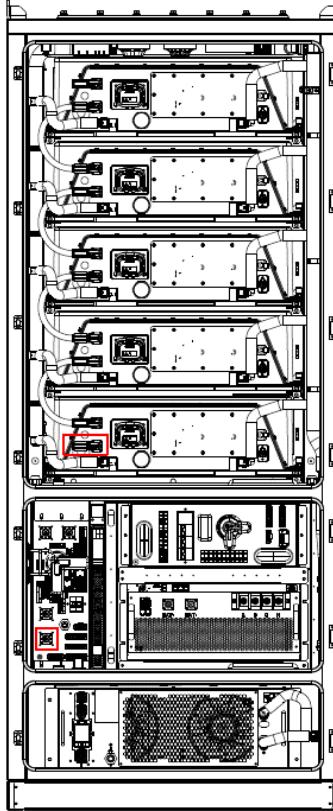

Figure Annex 4- 20 Insert the cable quick plug into the negative socket

3. Use the battery PACK connection cables to connect the positive and negative sockets of battery PACK1# to 5# in sequence (the cable color matches the plug). When you hear a 'click', it indicates that the connection is in place.

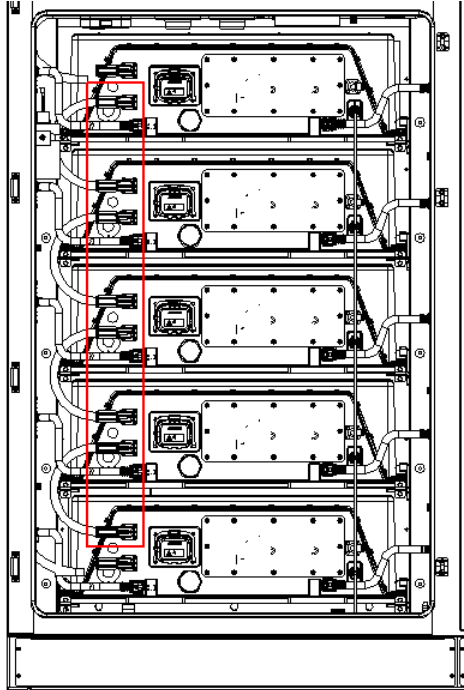

Figure Annex 4- 21 Install the battery PACK cables in sequence

4. Use the total positive connection cable between the battery PACK and the high voltage box to insert the cable plug into the positive socket of battery 5# PACK and the B+ socket of the high voltage box (the color matches the plug). When you hear a 'click', it indicates that the connection is in place.

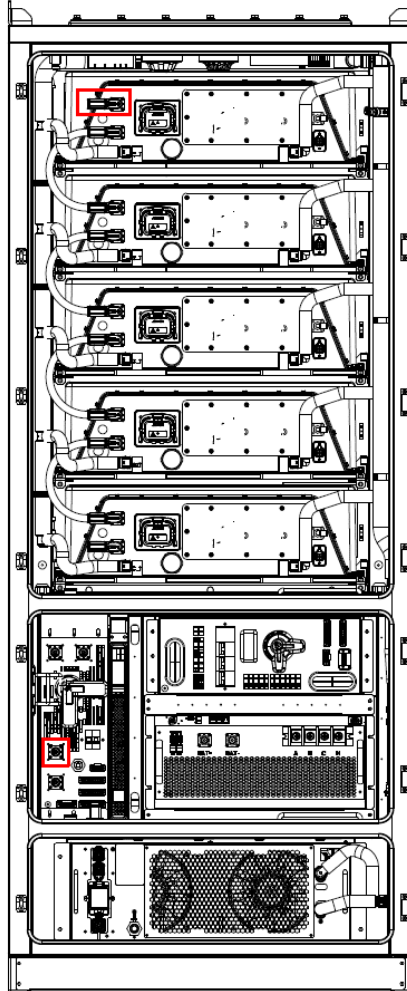

Figure Annex 4- 22 Connect total positive cable between battery PACK and high voltage box

### Annex 4.2.4.4 Communication Cable Installation

#### Warning



- Use signal cables that meet the following specifications.
- Do not insert both ends of the harness into the same "battery PACK".

The specifications of the signal cables connecting the high voltage box and the battery PACK are as follows:

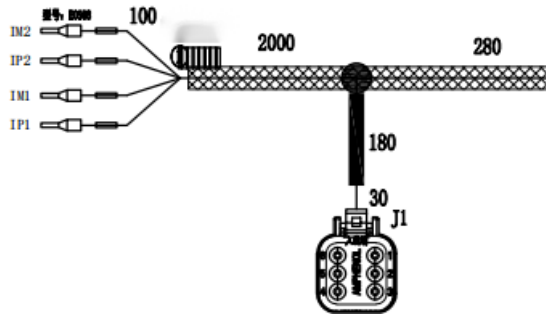

Figure Annex 4- 23 Communication harness between ESBCM and ESBMM

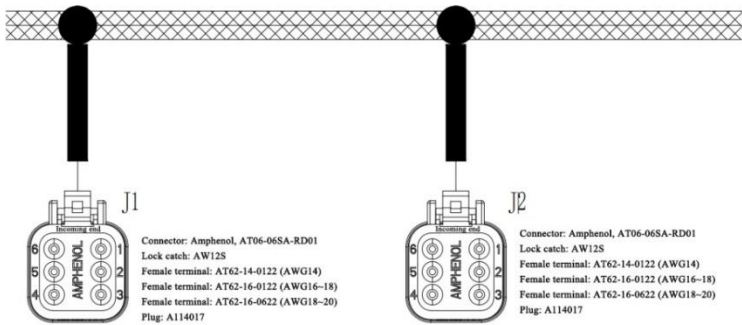

Figure Annex 4- 24 Communication harness pinout

Table Annex 4- 1 Communication harness pin definitions

J1-1	J1-2	J1-3	J1-4	J1-5	J1-6	J2-1	J2-2	J2-3	J2-4	J2-5	J2-6
IP1	IM1	IP2	IM2	Res.	Res.	IP1	IM1	IP2	IM2	Res.	Res.

Installation of communication/power harness between high voltage box and ESBMM, and between ESBMM and ESBMM:

1. Connect the communication/power harness between the high voltage box ESBMM and the 1# battery PACK;

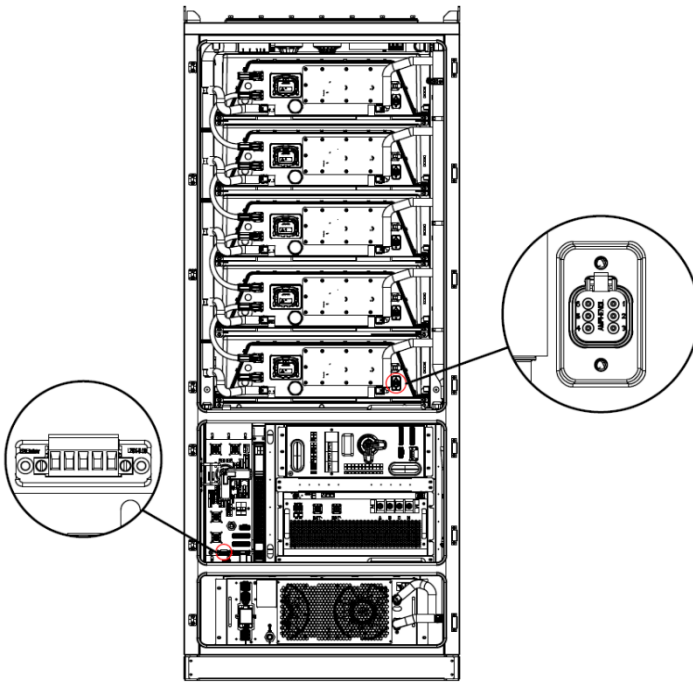

Figure Annex 4- 25 Connect communication/power harness between high voltage box and battery PACK

2. Connect the communication/power harness between the battery PACKs

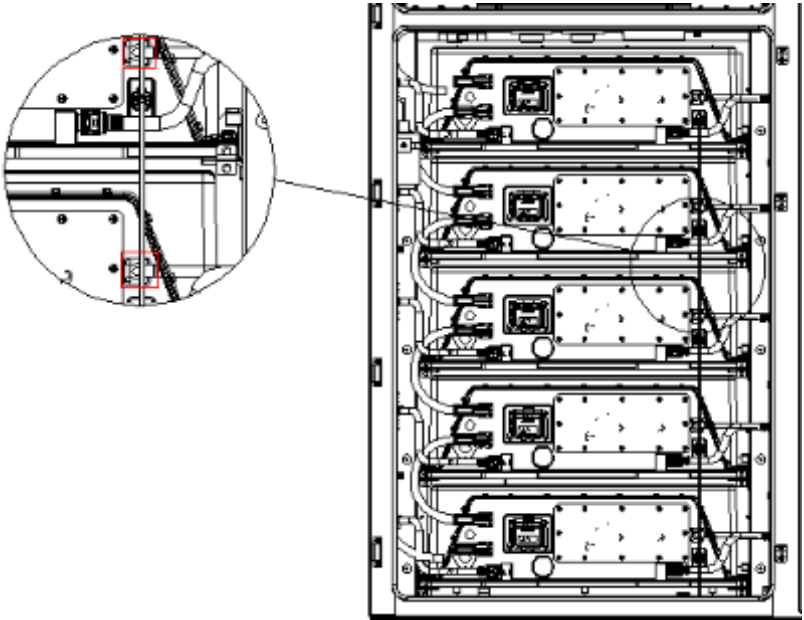

Figure Annex 4- 26 Connect communication/power harness between battery PACKs

#### Annex 4.2.4.5 AC Input Debugging

---

##### Warning



After the above harness installation is completed, sample check the bolt tightening condition, screw tightening torque, high voltage power cable connection, battery PACK connection, and high voltage box connection.

---

After the battery system is installed, the 24VDC input power of the BMS must be connected before the BMS system can be connected.

1. Before connecting the 24VDC auxiliary power of the high voltage box, please ensure that the disconnecter handle is in the "OFF" position.

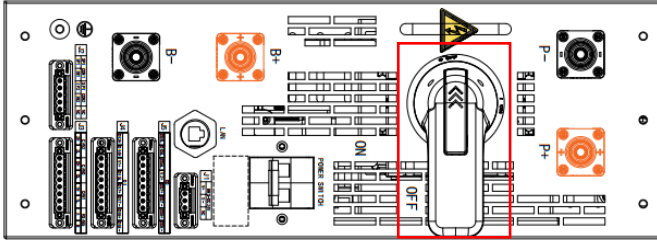

Figure Annex 4- 27 Disconnecter of high voltage box in the "OFF" position

2. Move the handle of the disconnecter to the "ON" position.

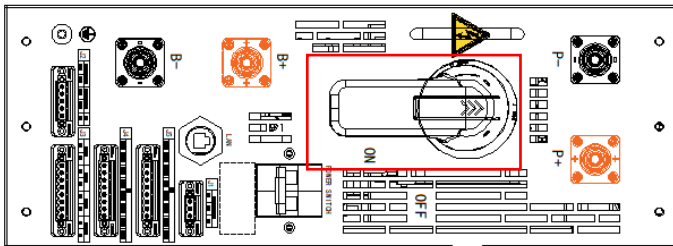

Figure Annex 4- 28 Disconnecter of high voltage box in the "ON" position

#### Annex 4.2.4.6 Liquid Cooling Pipeline Installation

---

##### Warning



Install the liquid cooling pipes according to the following content.  
(Normally, the primary, secondary and tertiary liquid cooling pipelines are already installed when the system is shipped.)

---

1. The main bodies of the secondary and tertiary pipes are already integrated when leaving the factory. The secondary pipe joint with a blue label should be connected to the male end of the primary pipe with a red label. It is necessary to confirm that the connector lock has been inserted into the connector slot and cannot be pulled out.

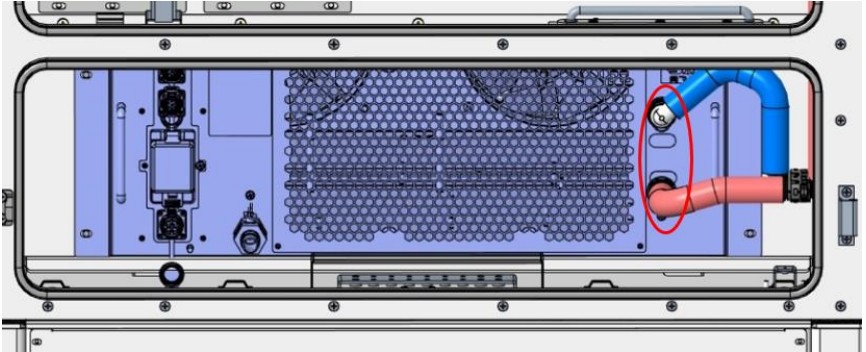

Figure Annex 4- 29 Connect the secondary pipe to the liquid cooling unit

2. Sequentially connect the tertiary inlet pipe joint to the male end of the battery PACK from 1# battery PACK to 5# battery PACK, and fasten the buckle. A 'click' sound should be heard to confirm that it is securely fastened and cannot be pulled out.

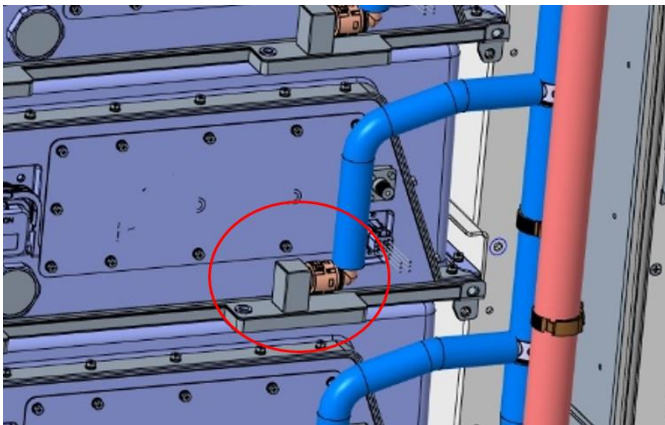

Figure Annex 4- 30 Connect the tertiary pipe to the battery PACK

3. Use 4 plastic pipe clamps to fix the secondary inlet pipe to the inner side panel of the cabinet. The clamps need to tighten the inner diameter to clamp the pipe and insert it into the fixed sheet metal hole. Ensure that there is no false insertion.

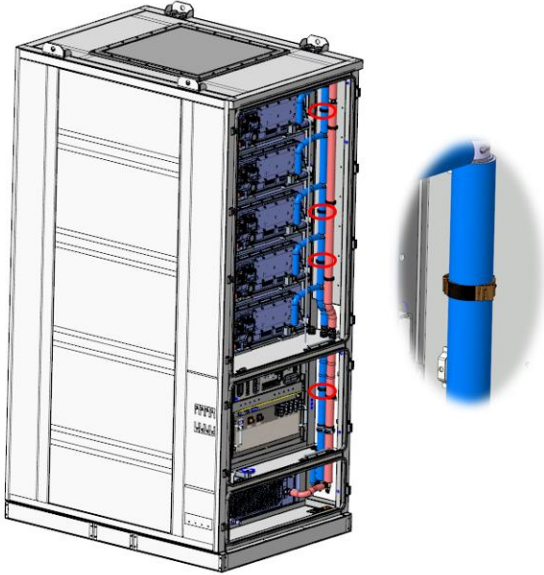

Figure Annex 4- 31 Fix the secondary pipe to the cabinet

4. Refer to the above steps to install the secondary and tertiary outlet pipes in sequence. Note: The outlet pipe has a red label attached.

### Annex 4.2.4.7 MSD Installation

1. Ensure that the high voltage box disconnecter is in the "OFF" state.

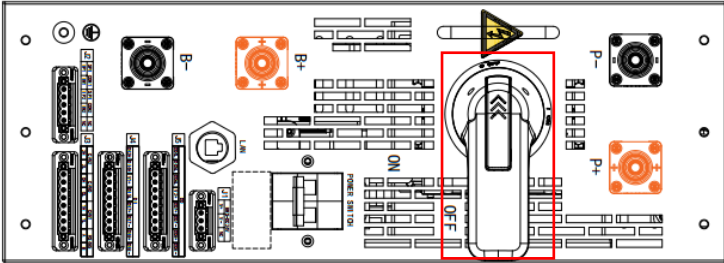

Figure Annex 4- 32 High voltage box disconnecter in the "OFF" position

2. Align the handle of the MSD cover vertically with the base guide slot on the battery PACK panel and push it in. After pushing it in, rotate the handle. After hearing a "click" sound, push in the secondary lock.

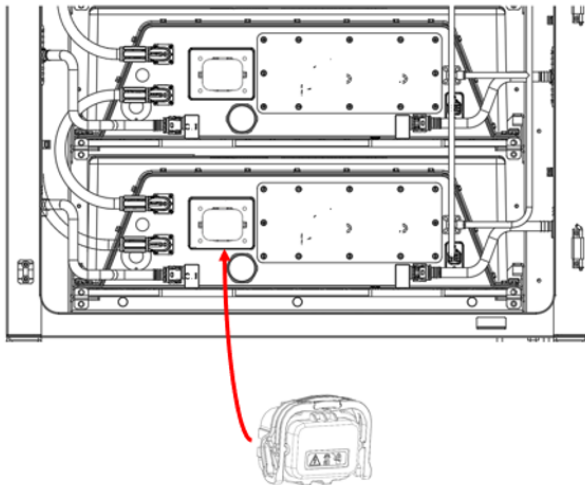

Figure Annex 4- 33 MSD installation position

3. Repeat the above steps and install them in sequence until the last battery PACK is installed.

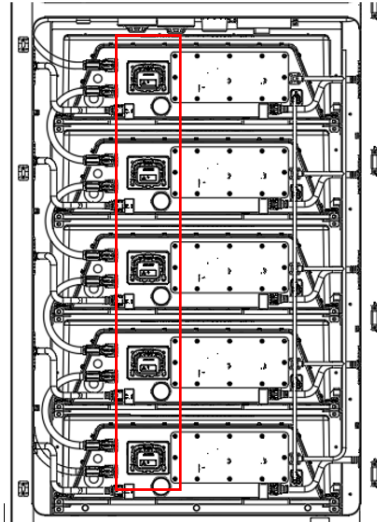

Figure Annex 4- 34 Complete MSD installation for all battery PACKs

4. Use the total positive connection cable between the battery PACK and the high voltage box. Insert the cable plug into the positive socket of battery 5# PACK and the B+ socket of the high voltage box (the color matches the plug). When you hear a 'click', it indicates that it is connected in place.

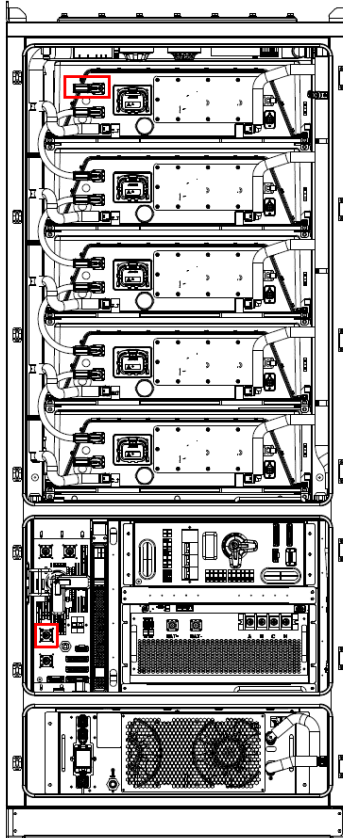

Figure Annex 4- 35 Connect battery PACK and high voltage box main positive cable

## Annex 4.2.5 Equipment Parameter Settings

### Annex 4.2.5.1 BMS Parameter Settings

1. Confirm the ESBCM (main control) version and ESMU (display control) version information.  
 ESBCM Version: SV\_CF133\_b3\_5.0.1\_GB1.118\_20241797\_01.33  
 ESMU version: AARCH64-ESMU-G01-ZT-V11-R20250514150113-SJ202401797-20
2. The IP address of ESBCM (main control) is 195.16.19.201  
 ESMU (display control) IP address: LAN0: 10.122.1.88, LAN2: 195.16.19.88.
3. Confirm the protection parameter threshold through ESMU.

Table Annex 4- 2 Protection parameter threshold

No.	Project	Alarm level	Alarm trigger threshold	Hysteresis value
1	Single cell voltage too high (V)	Minor	3.5	0.1
		Moderate	3.6	
		Serious	3.65	
2	Single cell voltage too low (V)	Minor	3.0	0.1
		Moderate	2.8	
		Serious	2.5	
3	Single cell voltage difference (mV)	Minor	350	100
		Moderate	400	

		Serious	600	
4	Battery charging cell temperature high (°C)	Minor	45	5
		Moderate	50	
		Serious	55	
5	Battery charging cell temperature low (°C)	Minor	5	5
		Moderate	0	
		Serious	-20	
6	Battery discharging cell temperature high (°C)	Minor	45	5
		Moderate	50	
		Serious	55	
7	Battery discharging cell temperature low (°C)	Minor	0	5
		Moderate	-10	
		Serious	-20	
8	Large temperature difference between cells in the cluster (°C)	Minor	10	5
		Moderate	15	
		Serious	20	

9	SOC low (1%)	Minor	10	5
		Moderate	0	
		Serious	0	
10	SOC high (1%)	Minor	95	5
		Moderate	100	
		Serious	100	
11	Total voltage too high (V) (*260)	Minor	3.5	22.5
		Moderate	3.6	
		Serious	3.65	
12	Total voltage too low (V) (*260)	Minor	3.0	22.5
		Moderate	2.8	
		Serious	2.5	
13	Power connector over-temperature alarm (°C)	Minor	65	5
		Moderate	70	
		Serious	80	
14	Charging overcurrent (A)	Minor	180	10
		Moderate	200	
		Serious	220	

15	Discharging overcurrent (A)	Minor	180	10
		Moderate	200	
		Serious	220	
16	Low insulation (KΩ)	Minor	1000	10
		Moderate	500	
		Serious	200	
17	Battery PACK voltage too high (V) (*52)	Minor	3.5	5
		Moderate	3.6	
		Serious	3.65	
18	Battery PACK voltage too low (V) (*52)	Minor	3.0	5
		Moderate	2.8	
		Serious	2.5	
19	Display control and ESBCM communication failure	Moderate	/	/
20	ESBCM and ESBMM communication failure	Serious	/	/
21	Display control detects external signals: fire alarm/emergency stop signal/electric operation	Serious	/	/
22	Single cell voltage acquisition failure	Serious	/	/
24	Single cell temperature acquisition failure	Serious	The number of invalid temperatures $\geq 2$	/

			or the number of slave controls with invalid temperatures $\geq 2$	
25	Temperature rise alarm	Moderate	The temperature rise rate of a single battery is greater than $>10^{\circ}\text{C}/\text{min}$	/
26	Main control: circuit breaker fault/contactor fault	Serious	/	/

**Annex 4.2.5.2 PCS Parameter Settings**

1. The default IP address of PCS is 10.122.1.221;
2. PCS version confirmation: Connect to the switch, use the host computer to read PCS version information, main DSP: 0.1.0.7.6.16 FPGA: 0.0.0.1.4.0 secondary DSP: 2025.2.24;
3. Set the corresponding parameters in the PCS host computer software according to the table below:

Table Annex 4- 3 Software parameter settings

Name	Parameter bit	Definition	Parameter code
23: Fault word	G23.00	Hardware fault word 1	0B,0000,0000,0000,0000
	G23.01	Hardware fault word 2	0B,0000,0000,0000,0000
	G23.02	Grid fault word	0B,0000,0000,0000,0000
	G23.03	Busbar fault word	0B,0000,0000,0000,0000
	G23.04	AC capacitor fault word	0B,0000,0000,0000,0000
	G23.05	System fault word	0B,0000,0000,0000,0000
	G23.06	Switch fault word	0B,0000,0000,0000,0000
	G23.07	Other fault word	0B,0000,0000,0000,0000
	G23.16	Hardware fault 1 mask word	0B,0000,0000,0000,0000
G.23.21	System fault word mask word	0B,1100,0010,0101,1000	
80.System configuration parameters	G.80.142	PCS heartbeat register 1-255	Check observation
	G.80.143	PCS communication heartbeat fault enable	Set parameter value to 1
20. Debug Control Quantity	G.20.05	Hardware Debug Command	0B,0000,0000,0000,0000
22. Save Register	G.22.51	Battery Overvoltage Point	960
	G.22.17	Bus Overvoltage Point	960

### Annex 4.2.5.3 LEMS Parameter Settings

1. LEMS uses the LAN2 port, the LAN1 address is 192.168.1.100, and the LAN2 address is 10.122.1.100.
2. LEMS confirms the liquid cooling unit setting parameters:

Table Annex 4- 4 LEMS liquid cooling unit parameter settings

Parameter name	Value	Unit
Cooling Setpoint	28	°C
Heating Setpoint	10	°C
Cooling sensitivity	2	°C
Heating sensitivity	4	°C

3. Other protection parameters and strategy parameter settings are modified according to project requirements.

### Annex 4.2.5.4 Liquid cooling unit Parameter Settings

1. To confirm the parameters of the liquid cooling unit, you need to connect the handheld screen to the debugging port.
2. Confirm the cooling sensitivity is 2°C and the heating sensitivity is 2°C.
3. Confirm that the Modbus-RTU communication address of the liquid cooling unit is 3.

### Annex 4.2.5.5 Dehumidification Parameter Settings

1. The parameters of the dehumidifier need to be set during the self-check state of the dehumidifier, which occurs during the startup phase of the dehumidifier.
2. The dehumidification start value is 50%, and the dehumidification stop value is 40%.
3. Confirm that the Modbus-RTU communication address of the dehumidifier is 1.

### Annex 4.2.5.6 Auxiliary Meter Parameter Settings

Refer to the following table for the parameters of Main Circuit Meter (kWh1).

Table Annex 4- 5 Main circuit meter (kWh1)

Parameter name	Value
Communication protocol	Modbus-RTU
Address	1
Baud rate	9600
Check bit	8
Stop bit	1
Check method	None
Voltage ratio	1
Current ratio	1

### Annex 4.2.5.7 I/O module Parameter Settings

1. The communication method between the I/O module (2n) and ESBCM is serial communication, and the dial code needs to be moved to position 2.
2. The communication method between the I/O module (6n) and ESBCM is serial communication, and the dial code needs to be moved to position 2.

## Annex 4.2.6 System Debugging

### Annex 4.2.6.1 Signage Test

1. The nameplate, company logo, and warning labels are correct, complete, clear, and comply with product standards.
2. The grounding symbol is clear, and the contact surface of the grounding device should be free of paint and rust.

### Annex 4.2.6.2 Cabinet/Door Inspection

1. The opening and closing of the cabinet/door should be flexible and smooth, with an opening angle of not less than 90°C.

2. During the opening and closing process of the box door/cabinet door, the coating should not be damaged and maintain sealing integrity. The protective strips around the door should be flat, without glue peeling or shrinkage. After opening and closing the door five times, lock it securely, with its movement not exceeding 2mm, and the door panel's verticality should meet the design requirements.
3. After closing the door, the door and the ventilation window should fit tightly around, with no light penetrating.

#### **Annex 4.2.6.3 Internal Appearance Inspection of the Cabinet**

1. The inner and outer surfaces of the cabinet should be evenly coated, without pinholes, bubbles, sagging, or bottom leakage. At a distance of 1 meter, no scratches, stains, or repair marks should be visible. The inside of the cabinet should be clean, without any debris such as thread ends, cable ties, or iron and copper shavings.
2. The inside of the cabinet, as well as the copper bars and components, should have a uniform and smooth coating with good adhesion, and there should be no signs of rust.
3. No water accumulation is found inside the cabinet.

#### **Annex 4.2.6.4 Inspection of Important Components**

The inside of the cabinet, the copper bars, and the coating of the components are uniform and smooth, with good adhesion and no signs of corrosion.

#### **Annex 4.2.6.5 Dust Filter Inspection**

The dust filter should be installed flat and without looseness, and the removal and insertion should be smooth without any jamming (pay attention to the air intake side of the dust filter).

#### **Annex 4.2.6.6 Important Electrical Contact Firmness Inspection**

The installation bolts of the system equipment should be tightened, the torque of each nut should meet the standard, and should be marked. The torque of the nuts at

key parts should be sampled and tested. The connection cables and grounding wires should be installed correctly and firmly.

#### **Annex 4.2.6.7 Connection between Battery PACKs and between Battery PACK and High Voltage Box (without MSD Installed)**

The connector should be pressed tightly, and the buckle should rebound in place. The nut should be tightened, and the polarity of the connecting harness should be checked for correctness.

#### **Annex 4.2.6.8 Connection between PCS and High Voltage Box**

The connector should be pressed tightly, and the buckle should rebound in place. The nut should be tightened, and the polarity markings of the PCS and battery PACK should be consistent.

#### **Annex 4.2.6.9 Connection of Control Circuits between Cabinets**

According to the 'wiring table', check whether the cables between the cabinets are laid correctly, and the wiring on the terminals should be consistent with the drawings. Pay special attention to the correct phase colors of the AC wire: color A (brown), B (black), C (gray), N (blue), PE (yellow-green). If the wire color does not meet the requirements, heat shrink tubing of the corresponding color must be used at both ends of the wire to mark the color. Communication lines must use twisted pair shielded wire or network cable.

#### **Annex 4.2.6.10 Auxiliary Circuit Power Supply Test**

1. Start the UPS. Ensure the 24V power module is supplying power normally and confirm that the LEMS and distribution box are powered.
2. Measure the line voltage at the incoming line end as 400VAC, and after confirming it is correct, close QF and observe the PCS power indicator turn on;
3. Close QF1 and confirm the meter is powered, and then check the meter parameters to confirm the AC line voltage is 400V;

4. Close QF2 and switch the UPS to AC power supply mode, and reset the alarm;
5. Close QF3 and confirm the dehumidifier and liquid cooling unit is powered;
6. Close QF4 and confirm the socket is powered.
7. Plug in the MSD and close the high voltage box disconnecter. Reset the terminal to clear the alarm via ESMU or power on ESBCM again to reset the BMS alarm information. After DC output is completed, the PCS should switch to the standby mode, and the system indicator light should show green.

#### **Annex 4.2.6.11 Communication Check and Protection Parameter Check**

Enter the LEMS IP address in the web page and log in for easy information comparison. LEMS reads the data between modules and checks the voltage, current, power, battery status, PCS status, thermal management system status, fire safety system status, ventilation device status, cabin temperature and humidity, etc.

#### **Annex 4.2.6.12 Charge and Discharge Test**

1. Connect the system to the AC source or grid, connect the auxiliary power supply, power on the BMS, thermal management system and fire safety system, close the QF switch, power on the PCS, close the high voltage box (modify the cooling point temperature to 22°C in the LEMS parameter setting interface), and close the door before the test to prevent condensation.
2. Send the system startup command through LEMS and record the equipment operation status.
3. Set the power to charge or discharge at 10%P<sub>n</sub>, and record the operating power value for a duration of 5min.
4. The liquid cooling unit should automatically refrigerate or heat during the test.
5. If operating at 10%P<sub>n</sub> without any alarms or protections, perform full power charging and discharging.

## Annex 5 Alarm and Fault Handling Instructions

### Warning



- The alarm handling of equipment such as battery, liquid cooling units, and fire safety system must be performed by qualified and authorized personnel.
- For some alarm handling items, it requires the system to be shut down first.
- This energy storage system product is a high voltage DC system and can only be operated by qualified and authorized personnel!
- Before troubleshooting, it is necessary to check whether all cable connections and settings of PCS and BMS are correct,
- Before troubleshooting, it is necessary to check whether the integrated cabinet can be powered on normally.

### Annex 5.1 Operational Procedures for C&I Integrated Cabinet

For specific operating procedures, please refer to 6.1 Operational Procedures for C&I Integrated Cabinet.

### Annex 5.2 System Alarms and Handling

#### Annex 5.2.1 LEMS Alarm Information

Table Annex 5- 1 LEMS alarm information

Alarm name	Alarm level	Fault reason	Handling suggestion
Cabinet-Level Aerosol Spray Alarm	Level 3	Aerosol spraying	Check the ignition source
Battery compartment	Level 2	Temperature detector activated	Refer to Annex 5 Alarm and Fault Handling

temperature sensor alarm			Instructions
Battery compartment smoke alarm	Level 2	Smoke detector activated	Refer to Annex 5 Alarm and Fault Handling Instructions
Fire level 1 alarm	Level 2	<ul style="list-style-type: none"> <li>• Combustible gas concentration <math>\geq</math> 10%LEL</li> <li>• Smoke detector activated</li> <li>• Temperature detector activated</li> <li>• Any of the above conditions is met</li> </ul>	<ul style="list-style-type: none"> <li>• Check if it is a false alarm</li> <li>• Check for any combustible gas leakage</li> <li>• Check the temperature of the battery cell</li> <li>• Check if there is any burning inside the cabinet</li> </ul>
Fire safety level 2 alarm	Level 3	<ul style="list-style-type: none"> <li>• Temperature sensor activation + combustible gas concentration <math>\geq</math> 20%LEL</li> <li>• Smoke detector and temperature sensor activate simultaneously</li> </ul>	Check the ignition source
PCS communication abnormality	Level 3	<ul style="list-style-type: none"> <li>• The network cable is loose</li> <li>• PCS IP address setting error</li> <li>• LEMS IP address setting error</li> </ul>	<ul style="list-style-type: none"> <li>• Check if the network cable connection is correct and if it is loose</li> <li>• Check if the LEMS IP settings are correct</li> <li>• Check if the PCS IP settings are correct</li> </ul>

BMS communication exception	Level 3	<ul style="list-style-type: none"> <li>• The network cable is loose</li> <li>• BMS IP address setting error</li> <li>• LEMS IP address setting error</li> </ul>	<ul style="list-style-type: none"> <li>• Check if the network cable connection is correct and if it is loose</li> <li>• Check if the LEMS IP settings are correct</li> <li>• Check whether the BMS IP settings are correct</li> </ul>
Communication abnormality of the gateway meter	Level 3	<ul style="list-style-type: none"> <li>• Wiring error</li> <li>• LEMS communication configuration error</li> <li>• Communication line interference</li> </ul>	<ul style="list-style-type: none"> <li>• Check whether the RS485 wiring is correct and whether it is loose</li> <li>• If the gateway meter adopts the DLT645 protocol, replacing the gateway meter requires modifying the LEMS communication configuration</li> <li>• If the gateway meter adopts the Modbus protocol, check the communication settings of the gateway meter</li> <li>• The communication line is subject to interference. The communication line should use shielded twisted pair, with one end of the shield</li> </ul>

			<p>grounded. When the distance is long, a 120 <math>\Omega</math> resistor can be connected in parallel between the A and B lines at both ends</p>
PV inverter communication abnormality	Level 2	<ul style="list-style-type: none"> <li>• Wiring error</li> <li>• RS485 address setting error</li> <li>• Communication line interference</li> </ul>	<ul style="list-style-type: none"> <li>• Check whether the RS485 wiring is correct and whether it is loose</li> <li>• Check the communication settings of the PV inverter</li> <li>• The communication line should use shielded twisted pair, with one end of the shielding layer grounded. When the distance is long, a 120 <math>\Omega</math> resistor can be connected in parallel between the A and B wires at both ends.</li> </ul>
LEMS black screen	Level 3	<ul style="list-style-type: none"> <li>• Power supply abnormality</li> <li>• LEMS screen is frozen</li> </ul>	<ul style="list-style-type: none"> <li>• Check if the power supply is normal</li> <li>• Restart LEMS</li> <li>• Restart the LEMS. If the BIOS can be accessed but the desktop cannot be</li> </ul>

---

			<p>entered, replace the hard disk.</p> <ul style="list-style-type: none"><li>• Restart the LEMS. If the BIOS cannot be accessed, replace the LEMS.</li></ul>
--	--	--	--

## Annex 5.2.2 BMS Alarm Information

Table Annex 5- 2 BMS alarm information

Alarm name	Alarm level	Fault reason	Handling suggestion
Single cell SOC high (mild)	Level 1	Prompt for high system capacity	No action required
Single cell SOC high (moderate)	Level 1	Full system reminder	No action required
Single cell/Battery PACK/total voltage overvoltage (mild)	Level 1	Prompt for high system capacity	No action required
Single cell/Battery PACK/total voltage overvoltage (moderate)	Level 1	Prompt for full system capacity	No action required
Single cell/Battery PACK/total voltage overvoltage (severe)	Level 2	<ul style="list-style-type: none"> <li>• System communication abnormality</li> <li>• PCS abnormality (no response to charge prohibition)</li> <li>• BMS abnormality (charge prohibition not executed)</li> </ul>	<ul style="list-style-type: none"> <li>• Check PCS status</li> <li>• Check communication status between BMS and PCS</li> </ul>
Single cell/Battery PACK/total voltage under-voltage (mild)	Level 1	System capacity low reminder	No action required
Single cell/Battery PACK/total voltage under-voltage	Level 1	System capacity depletion reminder	No action required, need to pay attention to system strategy

(moderate)			and recharge in time
Single/Battery PACK/Total voltage undervoltage (severe)	Level 2	<ul style="list-style-type: none"> <li>• System communication abnormality</li> <li>• PCS abnormality (no response to discharge prohibition)</li> <li>• BMS abnormality (discharge prohibition not executed)</li> </ul>	<ul style="list-style-type: none"> <li>• Check PCS status</li> <li>• Check communication status between BMS and PCS</li> </ul>
Charging/discharging temperature high (mild)	Level 1	System battery cell temperature is slightly high	Check the working status of the liquid cooling unit
Charging/discharging temperature is low (mild)	Level 1	The temperature of the system battery cell is low	Check the working status of the liquid cooling unit
Charging/discharging temperature is high (moderate/severe)	Level 2	The temperature control system is abnormal or the battery cell is abnormal	<ul style="list-style-type: none"> <li>• Check the working status of the liquid cooling unit</li> <li>• Check the battery status</li> <li>• Contact the manufacturer for repair</li> </ul>
The charging/discharging temperature is low (moderate/severe)	Level 2	The temperature control system is abnormal or the battery cell is	<ul style="list-style-type: none"> <li>• Check the working status of the liquid cooling unit</li> </ul>

		abnormal	<ul style="list-style-type: none"> <li>• Check the battery status</li> <li>• Contact the manufacturer for repair</li> </ul>
Charging prohibited	Level 1	System fully charged, charging prohibited alarm	No action required
Discharging prohibited	Level 1	System discharged, discharging prohibited alarm	No action required
ESBMM communication fault	Level 2	Battery PACK communication abnormal	<ul style="list-style-type: none"> <li>• Check whether the communication harness between the battery PACKs is abnormal</li> <li>• Check whether the communication between the high voltage box and the battery PACK is abnormal</li> <li>• Restart the high voltage box</li> <li>• Contact the manufacturer for repair</li> </ul>
Insulation resistance is slight/moderate/severe	Level 2	<ul style="list-style-type: none"> <li>• There may be a leakage on the DC side of the system</li> </ul>	<ul style="list-style-type: none"> <li>• The system is completely powered off,</li> <li>• Check DC cables</li> </ul>

		<ul style="list-style-type: none"> <li>• There may be insulation damage on the DC side of the system</li> <li>• The humidity inside the system is too high</li> </ul>	<ul style="list-style-type: none"> <li>• Check ambient humidity</li> <li>• Check the working status of the dehumidifier</li> <li>• Contact the manufacturer for repair</li> </ul>
Combustible gas concentration low/high	Level 2	Combustible gas exists in the battery PACK	The system is completely powered off, contact the manufacturer for repair.
Fire level 1 alarm	Level 2	There is an abnormality inside the battery PACK.	Contact the manufacturer for assistance.
Fire safety level 2 alarm	Level 2	There may be a fire risk inside the battery PACK.	<ul style="list-style-type: none"> <li>• Contact the manufacturer for assistance.</li> <li>• Cut off the AC source</li> <li>• Prepare fire extinguishing media (fire hydrant, etc.)</li> <li>• Contact the fire department for assistance</li> </ul>
Intake valve/exhaust valve failure	Level 2	<ul style="list-style-type: none"> <li>• There is a foreign object in the intake</li> </ul>	<ul style="list-style-type: none"> <li>• Check if there is any foreign object in the intake</li> </ul>

		valve/exhaust valve • Intake valve/exhaust valve failure	valve/exhaust valve; • Check if the intake valve/exhaust valve is abnormal; • Contact the manufacturer for repair or replacement
Dehumidifier communication lost	Level 2	Abnormal communication between the dehumidifier and BMS	• Check the status of the dehumidifier • Check the communication harness between the dehumidifier and BMS • Restart the system • Contact the manufacturer for repair
I/O device communication failure	Level 2	Abnormal communication between I/O device and BMS	• Check the status of the I/O device • Check the communication harness between the I/O device and BMS • Restart the system • Contact the manufacturer for repair

Liquid cooling unit communication lost	Level 2	Abnormal communication between liquid cooling unit and BMS	<ul style="list-style-type: none"><li>• Check the status of the liquid cooling unit</li><li>• Check the communication harness between the liquid cooling unit and BMS</li><li>• Restart the system</li><li>• Contact the manufacturer for repair</li></ul>
--	---------	--	--

## Annex 5.3 BMS Troubleshooting

Table Annex 5- 3 BMS faults and solutions

No.	Fault phenomenon	Solution
1	The ESMU does not work properly after powering on.	Record the observed phenomena and restart the power supply.
2	No data can be obtained on the display control screen.	Check whether the BMS cable is connected and whether the battery cluster IP address setting is incorrect.
3	The total voltage of a single battery cluster is too low, and the ESBMM has disconnected.	<ul style="list-style-type: none"> <li>• Check if the 24V line of the ESBMM is correctly connected;</li> <li>• Replace the ESBMM module and check if the module returns to normal.</li> </ul>
4	Abnormal voltage sampling of a single battery cell.	<ul style="list-style-type: none"> <li>• Remove the battery PACK and check if the sampling fuse is blown;</li> <li>• Replace the ESBMM module and check if the module returns to normal.</li> </ul>
5	ESBMM did not perform the balancing function.	<ul style="list-style-type: none"> <li>• Remove the battery PACK and check if the sampling fuse is blown;</li> <li>• Replace the ESBMM module and check if the module returns to normal.</li> </ul>
6	The display shows that the total cluster voltage is normal, but there is no current or three times the current during charging and discharging.	<ul style="list-style-type: none"> <li>• Check whether the contact resistance of the cluster circuit has increased;</li> <li>• Check whether the battery PACK is tight;</li> <li>• Check whether the fuse at the DC busbar is damaged;</li> <li>• Check whether the internal resistance of the battery PACK increases and whether the voltage is within the normal range.</li> </ul>

Note: If the BMS fault still cannot be resolved, please contact the after-sales service personnel.

## Annex 5.4 Battery PACK Replacement

For specific operation procedures, please refer to section Annex 4.2.4 Battery Replacement.

## Annex 5.5 Liquid Cooling Unit Troubleshooting

### Warning



- The liquid cooling unit is a professional equipment and can only be operated by qualified authorized personnel.
- Before replacing major components, the power supply and communication must be disconnected first.
- The maintenance and replacement of all components can only be carried out by qualified personnel, and only approved materials, parts and components can be used for replacement.

Table Annex 5- 4 Liquid cooling unit failure analysis table

Phenomenon	Possible reasons	Inspection items or handling methods
External circulation fan not running	Liquid cooling unit not powered	Check whether there is power at the power input terminal of the liquid cooling unit.
	Circuit breaker is tripped due to lightning stroke	Check whether the internal circuit breaker of the liquid cooling unit is closed.
	Abnormal power input of the liquid cooling unit (such as overvoltage or undervoltage)	Confirm whether there is a corresponding alarm in the liquid cooling unit, and if so, handle it according to the liquid cooling unit manual.

	Fan stuck	Check whether there is any foreign object stuck in the fan.
	Loose terminal	Check whether the fan docking terminal is loose.
	Compressor not started	Refer to the liquid cooling unit manual for the handling method when the compressor is not started.
	Control board failure	Replace the control board, refer to the liquid cooling unit manual to replace the control board
	Fan failure	Replace the fan, refer to the liquid cooling unit manual to replace the external circulation fan
Abnormal noise from the external circulation fan	The fan bearing is worn	Replace the fan, refer to the liquid cooling unit manual to replace the fan.
	The fan blade scratches other objects	Check if there are cables or other objects interfering with the fan blades.
Compressor not started	It is not powered on (in standby state)	Check the main power switch and the operation display interface to see if it is already turned on.
	Loose circuit connection	Tighten the circuit connectors.
	Open circuit or short circuit	Check for open or short circuits and repair the main power supply.
	Converter failure	Replace the frequency converter.

	Control board damaged	Replace the control board, refer to the liquid cooling unit manual to replace the control board.
	Compressor motor failure	Replace the compressor
The compressor is not working.	No cooling demand.	Check the output status of the compressor's liquid outlet temperature on the display interface. Check whether the operation interface is in the cooling state.
	Shutdown delay.	The compressor has the shortest shutdown time under normal conditions. If the temperature rises to the starting point during this period, the compressor will still start with a delay.
Exhaust pressure is high	Condenser is dirty and blocked	Clean the condenser using compressed air or a vacuum cleaner equipped with a brush head.
	The external circulation fan is not running	Refer to the table above.
The internal circulation water pump does not start	Power not turned on (standby)	Check the main power switch and the operation display interface to see if it is already turned on.
	Loose circuit connection	Tighten the circuit connectors.
	Water pump converter failure	Replace the water pump converter.

	Pump is in a self-protection state due to no coolant	Check if there is coolant in the circulation system, and if not, replenish it.
	Pump body failure	Replace the water pump. Refer to the liquid cooling unit manual to replace the water pump.
The electric heating tube is not working	No heating demand	Check whether the outlet temperature and heating set point are set reasonably.
	Loose circuit connection	Tighten the circuit connectors.
	Electric heating overheat protection	Wait for a period of time and then restart the electric heating, observe whether the electric heating is working normally.
	Electric heating fault	Replace the electric heating. Refer to the liquid cooling unit manual to replace the heater and circulation pump.
The automatic coolant refill pump is not operating	Coolant refill pump failure	Replace the automatic coolant refill pump.
	The coolant refill pump is stuck	Check if there are any foreign objects in the coolant refill tank, and remove them if present. If the coolant refill pump is damaged, please replace it.
	Loose terminal	Check if the docking terminal of the coolant refill pump is loose.

Automatic coolant refill pump makes abnormal noise	Axial of the coolant refill pump is worn	Replace the automatic coolant refill pump.
	Fixing screws of the coolant refill pump is loose	Tighten the screws.

---

## Annex 5.6 PCS Troubleshooting

---

### Warning



- There may be a risk of electric shock due to high voltage.
- Under fault conditions, the product may have high voltage. Touching the live parts of the equipment may lead to danger or death.
- May cause serious injury due to electric shock.
- Please follow all safety information when operating the product.
- When performing product maintenance, appropriate Personal Protective Equipment (PPE) must be worn.
- If you are still unable to resolve the issue through the following content, please contact the manufacturer.

---

PCS has complete protection functions and warning information. Once a fault occurs, relevant fault information can be read through EMS. Before seeking service, users can perform self-inspection according to the prompts in the table below, analyze the cause of the fault, and find a solution. During self-inspection, please do not disassemble machine components. If the problem cannot be solved, please contact the agent or our company directly.

Fault reset methods are divided into automatic reset and manual reset.

- Automatic reset fault refers to the system automatically clearing the fault at regular intervals after the fault occurs. If the fault condition is eliminated, the system exits the fault state; if the fault condition still exists, the fault is reported again. The number of automatic resets can be set by the function code. When the number of automatic resets is used up, the fault will no longer be automatically reset until the user manually resets the system, and the number of automatic resets is reloaded.
- Manual reset fault requires shutting down through the power on/off register after the cause of the fault is eliminated, and the PCS can only resume operation through the reset register.

Troubleshoot the PCS according to the following table:

Table Annex 5- 5 PCS troubleshooting

ID	Fault name	Trigger mechanism	Fault handling
1	EPO signal	External dry contact signal is abnormal Usage 1 (default): normally closed by default Closed: Normal Open: Fault; Usage 2 (customized): normally open by default Open: Normal Closed: Fault;	Power-off and restart the system
2	IGBT hardware overcurrent fault	IGBT OCP fault	Power-off and restart the system
3	Busbar hardware overvoltage fault	Busbar hardware voltage overvoltage	Power-off and restart the system

5	Power module wave-by-wave current limiting fault	Power module wave-by-wave current limiting	Power-off and restart the system
6	Balancing circuit wave-by-wave current limiting fault	Balanced circuit wave-by-wave current limiting	Power-off and restart the system
17	24V power supply failure	Internal auxiliary power supply failure	Power-off and restart the system
18	Fan failure	Fan stall	The system can automatically reset when the fault is cleared and the power-on command is 1 (1 indicates ON, 0 indicates OFF).
19	Single board connection fault	Internal connection fault	Power-off and restart the system
23	Lightning arrester fault	External dry contact signal is abnormal	Power-off and restart the system
24	Inductor overtemperature fault	Inductor temperature is greater than the limit	The system can automatically reset when the fault is cleared and the power-on command is 1 (1 indicates ON, 0 indicates OFF).

25	IGBT module overtemperature	IGBT temperature is greater than the limit	The system can automatically reset when the fault is cleared and the power-on command is 1 (1 indicates ON, 0 indicates OFF).
26	Balancing circuit overtemperature fault	Balancing circuit temperature is greater than the limit	The system can automatically reset when the fault is cleared and the power-on command is 1 (1 indicates ON, 0 indicates OFF).
27	15V power supply fault	Internal auxiliary power supply failure	Power-off and restart the system
28	External fire alarm fault	External dry contact signal is abnormal Usage 1 (default): normally closed by default Closed: Normal Open: Fault; Usage 2 (customized): normally open by default Open: Normal Closed: Fault;	Power-off and restart the system

29	External BMS dry contact fault	External dry contact signal is abnormal Usage 1 (default): normally closed by default Closed: Normal Open: Fault; Usage 2 (customized): normally open by default Open: Normal Closed: Fault;	It can automatically reset when the fault disappears.
31	Environment over-temperature fault	Environment temperature exceeds the limit	The system can automatically reset when the fault is cleared and the power-on command is 1 (1 indicates ON, 0 indicates OFF).
33	Grid overvoltage fault 3-phase 3-wire: line voltage $V_{ab}$ overvoltage; 3-phase 4-wire: phase voltage $V_{an}$ overvoltage;	Grid voltage exceeds the limit	It can automatically reset when the fault disappears.

34	Grid overvoltage fault 3-phase 3-wire: line voltage $V_{bc}$ overvoltage; 3-phase 4-wire: phase voltage $V_{bn}$ overvoltage;	Grid voltage exceeds the limit	It can automatically reset when the fault disappears.
35	Grid overvoltage fault 3-phase 3-wire: line voltage $V_{ca}$ overvoltage; 3-phase 4-wire: phase voltage $V_{cn}$ overvoltage;	Grid voltage exceeds the limit	It can automatically reset when the fault disappears.
36	Grid undervoltage fault 3-phase 3-wire: line voltage $V_{ab}$ undervoltage; 3-phase 4-wire: phase voltage $V_{an}$ undervoltage;	Grid voltage is less than the limit	It can automatically reset when the fault disappears.

37	Grid undervoltage fault 3-phase 3-wire: line voltage $V_{bc}$ undervoltage; 3-phase 4-wire: phase voltage $V_{bn}$ undervoltage;	Grid voltage is less than the limit	It can automatically reset when the fault disappears.
38	Grid undervoltage fault 3-phase 3-wire: line voltage $V_{ca}$ undervoltage; 3-phase 4-wire: phase voltage $V_{cn}$ undervoltage;	Grid voltage is less than the limit	It can automatically reset when the fault disappears.
39	Grid overfrequency fault	Grid frequency exceeds the limit	It can automatically reset when the fault disappears.
40	Grid underfrequency fault	Grid frequency is below the limit	It can automatically reset when the fault disappears.
41	Grid phase sequence error fault	Grid phase sequence A, B, C reversed	Power-off and restart the system, change phase sequence
42	AC phase A overcurrent fault	AC phase A current exceeds the limit	The system can automatically reset when the fault is cleared and the power-on command is 1

			(1 indicates ON, 0 indicates OFF).
43	AC phase B overcurrent fault	AC phase B current exceeds the limit	The system can automatically reset when the fault is cleared and the power-on command is 1 (1 indicates ON, 0 indicates OFF).
44	AC phase C overcurrent fault	AC phase C current exceeds the limit	The system can automatically reset when the fault is cleared and the power-on command is 1 (1 indicates ON, 0 indicates OFF).
46	AC current imbalance fault	The difference in current between phases A/B/C of the three-phase three-wire system exceeds the limit.	The system can automatically reset when the fault is cleared and the power-on command is 1 (1 indicates ON, 0 indicates OFF).
48	Neutral line overcurrent fault.	The neutral line current of the module exceeds the limit.	The system can automatically reset when the fault is cleared and the power-on command is 1 (1 indicates ON, 0 indicates OFF).
49	Pre-charge bus overvoltage fault.	Bus voltage during startup exceeds the limit.	The system can automatically reset when the fault is cleared and the power-on command is 1

			(1 indicates ON, 0 indicates OFF).
50	Precharge bus undervoltage fault	Bus voltage is less than the limit during startup	The system can automatically reset when the fault is cleared and the power-on command is 1 (1 indicates ON, 0 indicates OFF).
53	Bus overvoltage fault	Bus voltage is greater than the limit during operation	The system can automatically reset when the fault is cleared and the power-on command is 1 (1 indicates ON, 0 indicates OFF).
54	Bus under-voltage fault	The bus voltage during operation is less than the limit	The system can automatically reset when the fault is cleared and the power-on command is 1 (1 indicates ON, 0 indicates OFF).
55	Positive and negative bus imbalance fault	The voltage difference between the positive bus and the negative bus is greater than the limit	The system can automatically reset when the fault is cleared and the power-on command is 1 (1 indicates ON, 0 indicates OFF).
56	Battery undervoltage fault	Battery voltage is less than the limit	It can automatically reset when the fault

			disappears.
58	Battery overvoltage fault	Battery voltage is greater than the limit value	It can automatically reset when the fault disappears.
59	DC pre-charge overcurrent fault	DC current is greater than the limit value during startup phase	The system can automatically reset when the fault is cleared and the power-on command is 1 (1 indicates ON, 0 indicates OFF).
60	DC overcurrent fault	The DC current during operation exceeds the limit	The system can automatically reset when the fault is cleared and the power-on command is 1 (1 indicates ON, 0 indicates OFF).
61	Balancing circuit software overcurrent fault	The current of the balancing circuit during operation exceeds the limit	The system can automatically reset when the fault is cleared and the power-on command is 1 (1 indicates ON, 0 indicates OFF).
64	Battery reverse connection fault	Battery voltage is less than the limit	It can automatically reset when the fault disappears.
65	AC pre-charging timeout fault	During charging, the predetermined value was not reached within the	The system can automatically reset when the fault is cleared and the power-

		specified time.	on command is 1 (1 indicates ON, 0 indicates OFF).
66	AC pre-charging phase A overcurrent fault	Pre-charging phase module overcurrent	The system can automatically reset when the fault is cleared and the power-on command is 1 (1 indicates ON, 0 indicates OFF).
67	AC pre-charging phase B overcurrent fault	Pre-charging phase module overcurrent	The system can automatically reset when the fault is cleared and the power-on command is 1 (1 indicates ON, 0 indicates OFF).
68	AC pre-charging C-phase overcurrent fault	Pre-charging phase module overcurrent	The system can automatically reset when the fault is cleared and the power-on command is 1 (1 indicates ON, 0 indicates OFF).
71	Leakage current fault	Leakage current exceeds the limit	Power-off and restart the system. It is recommended to check if the system connection is normal.
81	Control board RAM fault	Control board RAM chip read/write error	Contact the manufacturer

82	Control board EEPROM fault	EEPROM read/write error	Contact the manufacturer
83	Control board ADC zero drift too large fault	ADC analog sampling channel zero drift too large	Contact the manufacturer
84	Control board background communication protocol fault	Communication protocol mismatch between DSPs	Contact the manufacturer
85	Control board CAN communication protocol fault	The communication protocol between CAN does not match	Contact the manufacturer
86	Control board CPLD communication protocol failure	The versions of CPLD and DSP do not match	Contact the manufacturer
87	Control board DataLog data failure	Control board DataLog data failure	Contact the manufacturer
90	Software Firmware (FW) Mismatch Fault	Software Firmware (FW) Mismatch Fault	Contact the manufacturer

92	BMS Battery Status Fault	BMS Status	View BMS Status
93	STS communication failure	The system did not detect the STS signal	The system can automatically reset when the fault is cleared and the power-on command is 1 (1 indicates ON, 0 indicates OFF).
94	BMS communication failure	The system did not detect the BMS signal	The system can automatically reset when the fault is cleared and the power-on command is 1 (1 indicates ON, 0 indicates OFF).
95	Parallel system slave communication failure	The system did not detect the parallel signal	The system can automatically reset when the fault is cleared and the power-on command is 1 (1 indicates ON, 0 indicates OFF).
96	EMS communication failure	The system did not detect the EMS signal	The system can automatically reset when the fault is cleared and the power-on command is 1 (1 indicates ON, 0 indicates OFF).

97	Pre-charging switch closing failure	Pre-charging switch closing failure	The system can automatically reset when the fault is cleared and the power-on command is 1 (1 indicates ON, 0 indicates OFF).
98	Precharge switch disconnection fault	Precharge switch disconnection fault	The system can automatically reset when the fault is cleared and the power-on command is 1 (1 indicates ON, 0 indicates OFF).
99	Precharge switch closure status error	Precharge switch closure status error	The system can automatically reset when the fault is cleared and the power-on command is 1 (1 indicates ON, 0 indicates OFF).
100	Precharge switch disconnection status error	Precharge switch disconnection status error	The system can automatically reset when the fault is cleared and the power-on command is 1 (1 indicates ON, 0 indicates OFF).
101	AC main switch closing fault	AC main switch closing fault	The system can automatically reset when the fault is cleared and the power-on command is 1 (1 indicates ON, 0 indicates OFF).

102	AC main switch opening fault	AC main switch opening fault	The system can automatically reset when the fault is cleared and the power-on command is 1 (1 indicates ON, 0 indicates OFF).
103	AC main switch closing status error	AC main switch closing status error	The system can automatically reset when the fault is cleared and the power-on command is 1 (1 indicates ON, 0 indicates OFF).
104	AC main switch disconnected state error	AC main switch disconnected state error	The system can automatically reset when the fault is cleared and the power-on command is 1 (1 indicates ON, 0 indicates OFF).
105	AC main switch adhesion fault	AC main switch adhesion fault	Do not power off, contact the manufacturer in time. If it has already been powered off, do not power it on again
106	DC main switch open circuit fault	DC main switch open circuit fault	Do not power off, contact the manufacturer in time

107	AC main switch open circuit fault	AC main switch open circuit fault	Do not power off, contact the manufacturer in time
113	Off-grid operation inverter overvoltage fault 3-phase 3-wire: line voltage $V_{ab}$ overvoltage; 3-phase 4-wire: phase voltage $V_{an}$ overvoltage;	Off-grid operation, inverter voltage exceeds the limit	The system can automatically reset when the fault is cleared and the power-on command is 1 (1 indicates ON, 0 indicates OFF).
114	Off-grid operation inverter overvoltage fault 3-phase 3-wire: line voltage $V_{bc}$ overvoltage; 3-phase 4-wire: phase voltage $V_{bn}$ overvoltage;	Off-grid operation, inverter voltage exceeds the limit	The system can automatically reset when the fault is cleared and the power-on command is 1 (1 indicates ON, 0 indicates OFF).
115	Off-grid operation inverter overvoltage fault 3-phase 4-wire: line voltage $V_{ca}$ overvoltage; 3-phase 4-wire: phase	Off-grid operation, inverter voltage exceeds the limit	The system can automatically reset when the fault is cleared and the power-on command is 1 (1 indicates ON, 0 indicates OFF).

	voltage $V_{cn}$ overvoltage;		
116	Grid islanding fault	Phase-locked frequency exceeds the limit	The system can automatically reset when the fault is cleared and the power-on command is 1 (1 indicates ON, 0 indicates OFF).
118	System resonance fault	AC filter capacitor current exceeds the limit	The system can automatically reset when the fault is cleared and the power-on command is 1 (1 indicates ON, 0 indicates OFF).
121	HVRT timeout fault	High voltage duration exceeds limit	The system can automatically reset when the fault is cleared and the power-on command is 1 (1 indicates ON, 0 indicates OFF).
122	Off-grid operation inverter voltage under-voltage fault 3-phase 3-wire: line voltage $V_{ab}$ undervoltage; 3-phase 4-wire: phase	Off-grid operation, inverter voltage is less than limit	The system can automatically reset when the fault is cleared and the power-on command is 1 (1 indicates ON, 0 indicates OFF).

	voltage Van undervoltage;		
123	Off-grid operation inverter voltage under-voltage fault 3-phase 3-wire: line voltage Vbc undervoltage; 3-phase 4-wire: phase voltage Vbn undervoltage;	Off-grid operation, inverter voltage is less than limit	The system can automatically reset when the fault is cleared and the power-on command is 1 (1 indicates ON, 0 indicates OFF).
124	Off-grid operation inverter voltage fault 3-phase 3-wire: line voltage Vca undervoltage; 3-phase 4-wire: phase voltage Vcn undervoltage;	Off-grid operation, inverter voltage is less than limit	The system can automatically reset when the fault is cleared and the power-on command is 1 (1 indicates ON, 0 indicates OFF).
125	Off-grid mode no synchronization signal fault	Off-grid operation, phase-locked synchronization signal not detected	Do not power off, contact the manufacturer in time
127	Off-grid output short circuit fault	Off-grid operation, inverter voltage is less than the limit and output current is greater than the limit	Do not power off, contact the manufacturer in time

---

128	LVRT timeout fault	Low voltage duration exceeds the limit	The system can automatically reset when the fault is cleared and the power-on command is 1 (1 indicates ON, 0 indicates OFF).
-----	--------------------	--	---

## Annex 5.7 Fire Product Troubleshooting

Table Annex 5- 6 Fire product troubleshooting

Phenomenon	Possible reasons	Inspection items or handling methods
Smoke detector false alarm or failure to trigger fire alarm	Detector is contaminated or damaged	Check if the detector is too dirty, return to the factory for repair or replacement
Temperature sensor false alarm or failure to trigger fire alarm	Detector damaged	Return to factory for repair or replacement

### Annex 5.7.1 Combustible Gas Detector Troubleshooting

#### Annex 5.7.1.1 Routine Maintenance

The reasons for sensor failure or poisoning are the presence of silicon, sulfur, chlorine, lead, and hydrocarbons containing halogen elements in the environment. The CROW CON company uses anti-poisoning sensors to maximize the lifespan of the sensors. The lifespan of the sensors depends on the number of gas leaks and the gas concentration values in practical applications. Under normal circumstances, the lifespan of the sensors is 3-5 years (calibration is required every 6 months). The CROW CON company recommends recalibrating every 6 months, and the number of calibrations depends on the on-site environment, such as dirty and hot environments where the number of calibrations should be increased.

Regularly check the sintered disc, and replace it promptly once contamination is found, because a contaminated sintered disc will block gas from entering the sensor. When maintaining the xgard Bright explosion-proof standard output gas detector, ensure that the sensor holder and the O-ring of the explosion-proof housing cover, as well as the explosion-proof glass of the explosion-proof upper cover, are in good condition to provide protection. If replacing the O-ring, please refer to the spare parts

and accessories list.

### Annex 5.7.1.2 Maintenance of sensors and probes

xgard Bright adopts a modular structure combination for easy sensor replacement, and the sensor replacement uses a plug-and-pull method. Refer to the manual of xgard Bright for the maintenance of xgard Bright.

## Annex 5.8 Dehumidifier Troubleshooting

After powering on, the dehumidification device enters the self-check state, after the self-check is completed, the dehumidification device enters the working state after 3 seconds, and the digital tube displays the humidity value of the box.

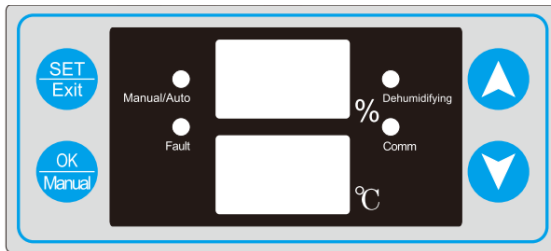

Figure Annex 5- 1 Dehumidifier indicator

Indicator	Status	Description
Manual/Automatic	On	The dehumidifier is in manual operation mode.
	Off	The dehumidifier is in automatic operation mode.
Dehumidification	On	The dehumidifier is currently dehumidifying.
	Off	The dehumidification is complete.
Communication	On	It is currently receiving data from the host
Fault	On	A fault is occurring. <ul style="list-style-type: none"> <li>If the humidity value shows "---", it indicates that a fault occurs in the humidity sensor or water droplets;</li> <li>If the temperature value shows "---", it indicates that a fault occurs in the temperature sensor</li> </ul>

If a fault code is displayed on the display, refer to the description of the fault codes as shown in the following table.

Fault code	Description
E2	External temperature sensor fault
E3	Cold surface temperature sensor fault
E4	Hot surface temperature sensor fault
E5	External ambient temperature too high
E6	Environment temperature too high

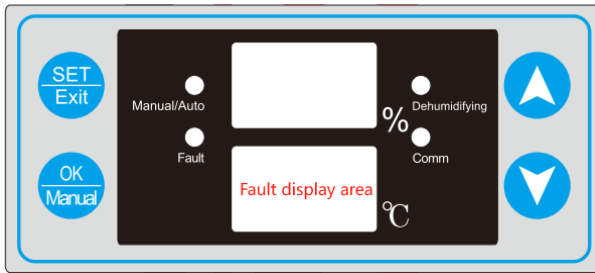

Figure Annex 5- 2 Dehumidifier fault indicator

## Annex 5.9 UPS troubleshooting

- UPS is professional equipment and can only be operated by qualified authorized personnel.
- Before replacing major components, the power supply and communication must be disconnected first.
- The maintenance and replacement of all components can only be performed by qualified personnel and only using approved
- Materials, components, and parts for replacement.

For details, refer to the UPS User Manual.

## Annex 5.10 System Processing

The decommissioning and disposal of the integrated cabinet at the end of its service life shall be the responsibility of the system owner and comply with local regulations or requirements regarding waste disposal or recycling.

The decommissioning and disposal of the battery PACK shall be carried out in accordance with the following provisions:

If the battery PACK is physically damaged, smoked, burned, or has reached the end of its life, please note the following instructions:

- Keep the battery PACK stationary for 24 hours to ensure no further danger;
- Use appropriate temperature measurement tools (such as a temperature gun) to check if the battery PACK temperature is higher than the ambient temperature;
- Wear insulated gloves when moving the battery PACK;
- Ensure external insulation of the battery PACK during transportation;
- Ensure the high voltage box disconnecter is in the off state;
- Ensure that the original plastic cover is in place at the battery PACK output terminals for protection/insulation;
- Place the battery PACK into a plastic bag;
- Secure the battery PACK to avoid further vibration and impact;
- Prevent the battery PACK from being exposed to rain or water.

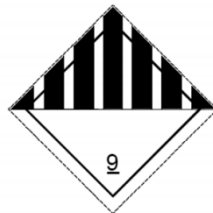

Lithium-ion battery



---

## Annex 6 System Maintenance Instructions

### Annex 6.1 System Maintenance

---

#### Note



- The operation and maintenance of equipment such as battery PACK, liquid cooling unit, and fire safety system must be performed by qualified and authorized personnel.
- Some maintenance items require the system to be shut down first.

---

If the system has been running for more than six months or has not been running for a long time, safety maintenance should be performed, and corresponding records should be made. The specific items are as follows:

- Check whether the safety door, front door, and battery compartment door of the integrated cabinet can be opened normally, and ensure that the environment inside and outside the integrated cabinet is clean and tidy;
- Check whether the fire extinguishing system can alarm and start normally, and whether there are firefighting equipment around the integrated cabinet for emergency use in case of an accident;
- Check whether the insulation of each power line is abnormal, whether the electrical safety gap meets safety standards, and whether the wiring bolts are loose;
- Check whether the electrical components are normal and whether the power doors of each power supply can be effectively disconnected.

### Annex 6.2 C&I Integrated Cabinet Power-Off Operation Procedure

For specific operating procedures, please refer to 6.1 Operational Procedures for C&I Integrated Cabinet.

## Annex 6.3 Battery PACK Maintenance

### Annex 6.3.1 Battery PACK Maintenance Procedure

Table Annex 6- 1 Battery PACK maintenance procedure

Maintenance frequency	Category	Maintenance content	Remarks
Quarter	Voltage Check	Check the battery system voltage through the monitoring system. Check if the system voltage is abnormal. For example: the voltage of a single battery PACK is too high or too low.	
	SOC check	Check the SOC of the battery system through the monitoring system. Check whether the SOC of the battery cluster is abnormal.	
	Cable check	Visually inspect all cables of the battery system. Check whether the cable is broken, aged, or loose.	
	Balancing check	Not fully charging for a long time will cause the battery PACK to become unbalanced.  Solution: Perform balancing maintenance (charge to full) every 3 months, which is normally automatically completed by the system communicating with external devices.	
	Output relay check	Under low load conditions (low current), control the output relay OFF	

		and ON, and hear the relay click, which means that the relay can be normally disconnected and connected.	
	Check of historical records	Analyze historical records, check whether there are accidents (alarms and protections), and analyze their causes.	
Semi-annual	Dust check	Keep the battery compartment clean.	
	Temperature	Measure and record the ambient temperature in the battery compartment.	
	Appearance	Check the appearance cleanliness of each battery; inspect the terminals and terminal covers for damage or signs of overheating.	
	Voltage	Check the battery system voltage through the monitoring system. Check whether the system voltage is abnormal.  For example: the voltage of a single battery PACK is too high or too low.	
	Shutdown and maintenance	During the network management restart, some system functions need to be maintained. It is recommended to perform the following operations: maintain the system every 6 months.	
Annual	Repeat	Repeat quarterly maintenance and inspection.	
	Tightness check	Check whether the cable joints are loose every year and tighten them.	

	Discharge test	<p>Perform a discharge test once a year to check the accurate load, with a discharge capacity of 30-40% of the rated capacity.</p> <p>After three years of operation, perform an 80% DOD capacity test once a year. Before the discharge test, the system should be fully charged.</p>	
--	----------------	--	--



## Annex 6.3.2 Battery PACK replacement

For specific operation procedures, please refer to Annex 4.2.4 Battery Replacement.

### Annex 6.3.2.1 External Cable Installation

1. The integrated cabinet contains grid connection ports and important load connection ports;

Phase	Cable	Incoming Direction	Outgoing Direction	Bolt	Torque
L1/L2/L3/ N	Single-phase $\geq$ 70mm <sup>2</sup> copper*4	QF	User grid connection point	M10	25 N·m

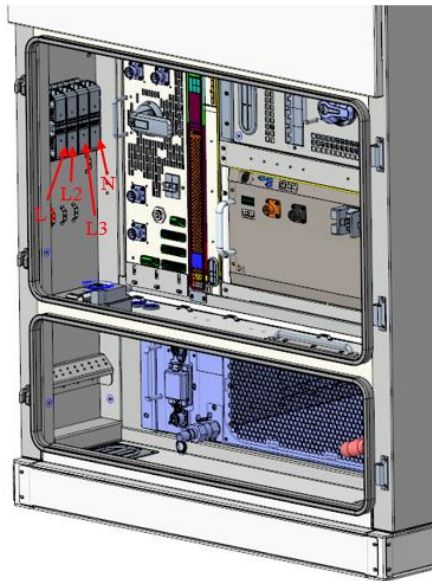

Figure Annex 6- 2 AC cable wiring

### Annex 6.3.2.1.1 Making Cable Terminals

Note:

DT terminals need to be prepared by the customer. When using copper core cables, please use copper terminals. When using copper-clad aluminum cables, please use copper terminals. When using aluminum alloy cables, please use copper-aluminum transition terminals, or aluminum terminals with copper-aluminum transition washers.

Attention:

The cavity formed by the crimping of the conductor crimping piece of the DT terminal should completely cover the cable core, and the cable core and DT terminal should be tightly combined without loosening.

DT cable terminal making tools:

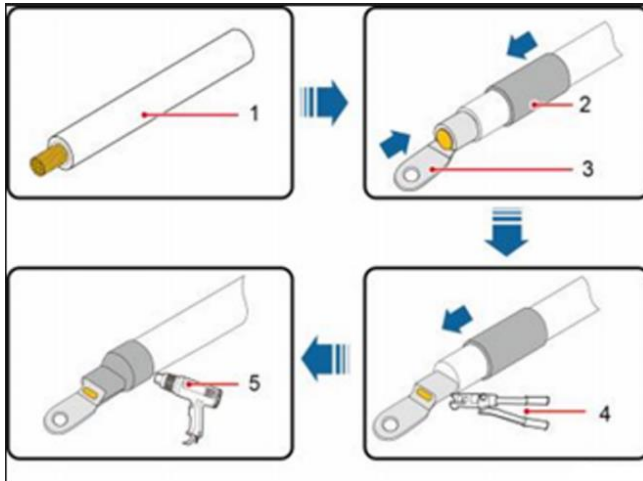

No.	Description
1	Cable
2	Heat Shrink Tubing
3	DT Terminal
4	Hydraulic Pliers
5	Hot Air Gun

Figure Annex 6- 3 Making crimp terminals

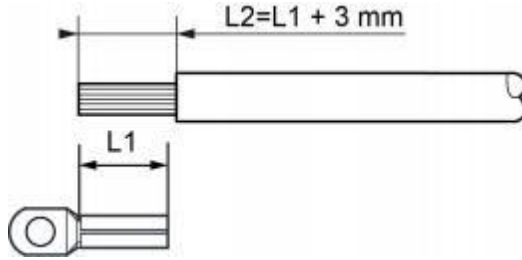

Figure Annex 6- 4 Grounding wire stripping reference length

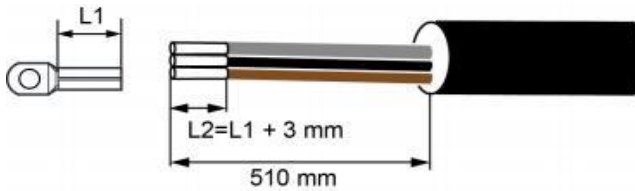

Figure Annex 6- 5 Output AC power wire stripping reference length

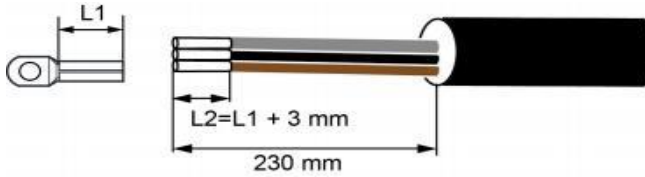

Figure Annex 6- 6 Input AC power wire stripping reference length

### Annex 6.3.2.1.2 Connect the cable

1. Open the front door panel

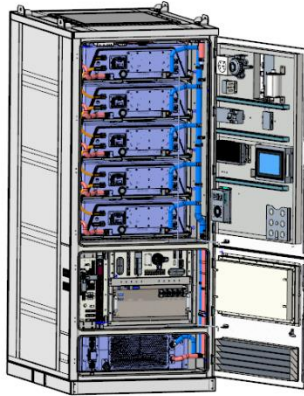

Figure Annex 6- 7 Open the front door panel

- a. Use the door lock key provided with the cabinet to open the front door lock;
  - b. Open the front door, and use the door stopper bracket under the door panel to secure the front door.
2. Connect the grounding wire

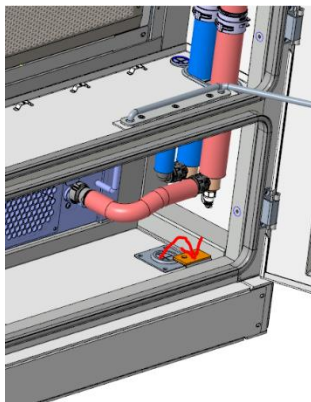

Figure Annex 6- 8 Connect grounding wire

3. Connect the output power cable

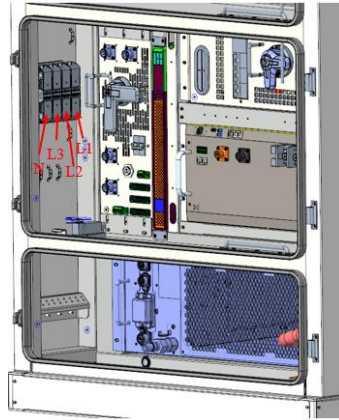

Figure Annex 6- 9 Connect output power cable

**Note**

- Each phase terminal can connect two cables;
- The specific wiring phase sequence follows the color of the copper busbar heat shrink sleeve, brown L1, black L2, gray L3, blue N.

4. Close the front door panel

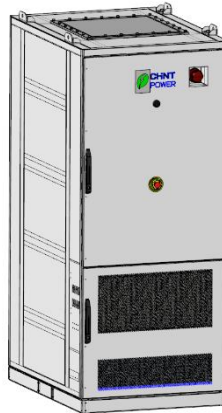

Figure Annex 6- 10 Close the front door panel

- a. Remove the limit bracket that fixes the front door and place it in the initial position;

- b. Close the front door and ensure that the door lock is in a fully locked state;

Check the correctness and firmness of the wiring. After confirmation, please use fireproof mud to seal the inlet and outlet areas.

#### **Annex 6.3.2.2 Liquid Cooling Pipeline Installation**

For specific operating procedures, please refer to section Annex 4.2.4.6 Liquid Cooling Pipeline Installation.

#### **Annex 6.3.2.3 MSD Installation**

For specific operating procedures, please refer to section Annex 4.2.4.7 MSD Installation.

## Annex 6.4 Liquid Cooling Unit Maintenance Procedure

Table Annex 6- 3 Liquid cooling unit maintenance procedure

Frequency	Category	Maintenance standard	Detection method	Handling method
Quarter	Unit appearance	The unit is clean, free of dust, and free of dirt;	Visual inspection	After power off for 10 minutes, use a brush or cotton cloth to remove dust and dirt from the unit.
	Fan operation reliability	The fan is free of dust, and there are no foreign objects blocking the air outlet.	Visual inspection	After power off for 10 minutes, use a brush to clean the dust from the fan. Remove any obstructions at the air outlet.
	Condenser cleaning	The condenser is free of dust and foreign object blockage.	Visual inspection	After power off for 10 minutes, use compressed air or a vacuum cleaner equipped with a brush head to clean the condenser.
		The fins are not severely	Visual inspection	After power off for 10

		bent or deformed.		minutes, use tools such as a fin comb to correct the fins.
Half a year	Wiring panel power cord cable, power terminal reliability	Electrical cables and terminals No loosening	Visual inspection	After power off for 10 minutes, use a screwdriver to tighten the loose cables.
		Electrical cables show no signs of aging, breakage, damage, abnormal heating, or other abnormalities.	Visual inspection	Replace the power cable after power off for 10 minutes.
		No dust at the wiring panel.	Visual inspection	After power off for 10 minutes, clean the dust with a brush.
	Reliable operation of the fan.	<ul style="list-style-type: none"> <li>• The fan blades are intact and rotating.</li> <li>• The fan operates smoothly without abnormal noise.</li> </ul>	Visual inspection	After power off for 10 minutes, check the fan for tightness and check if there are any internal cables or other obstructions interfering with the fan rotation. If the fan is faulty, please replace it.

	Coolant	<ul style="list-style-type: none"><li>• The concentration meets the range requirements.</li><li>• The PH value and electrolyte concentrations meet the requirements.</li><li>• No dirt, sediment, or algae is produced.</li></ul>	<ul style="list-style-type: none"><li>• Coolant detector</li><li>• Visual inspection</li></ul>	Replace the coolant 10 minutes after power off.
--	---------	---	--	---

### Annex 6.4.1 Liquid Cooling Unit Replacement

Before replacing the liquid cooling unit, the system power should be disconnected. Refer to the previous section for the operation process.

After turning off the power of the liquid cooling unit, the coolant in the liquid cooling unit and pipes should be drained first. The operation steps are as follows:

1. Prepare a coolant collection bucket, open the plug at the bottom of the liquid cooling pipe, connect a drain pipe to the bottom end, and insert one end of the drain pipe into the bucket.



Figure Annex 6- 11 Drain outlet at the bottom of the liquid cooling pipeline



Figure Annex 6- 12 Coolant container

2. The coolant will continuously drain into the collection container through the drain pipe; if no liquid flows out of the drain pipe within 30 seconds, it is considered that the draining is complete.
3. Remove the drain pipe and plug the opening with a stopper.
4. Disconnect the communication and power supply cables on the left side of the liquid cooling unit (as shown in the red circle in the figure below).



Figure Annex 6- 13 Communication and power supply interfaces

5. Remove the pipeline interface at the inlet and outlet of the liquid cooling unit (as shown in the red circle in the figure below).



Figure Annex 6- 14 Remove the inlet and outlet pipes of the liquid cooling unit

6. Use a torque gun to remove the 4 fixing screws of the liquid cooling unit, torque:  $5.9 \pm 0.2$  N·m.



Figure Annex 6- 15 Position of the fixing screws of the liquid cooling unit

7. Pull out the liquid cooling unit from the cabinet and replace it with a new one. For the installation of the liquid cooling unit, the connection of the liquid cooling pipeline, and the connection of the communication/power supply cable, refer to steps 4~6.

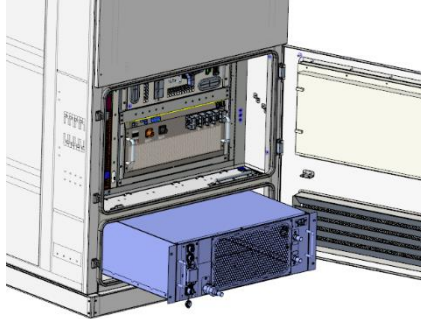

Figure Annex 6- 16 Pull out liquid cooling unit

8. Perform the liquid replenishment operation on the connected system. For details on the liquid replenishment operation, refer to Annex 6.4.3 Instructions for Liquid Replenishment After Equipment Replacement.

### **Annex 6.4.2 Liquid Cooling Pipeline Replacement**

For detailed operation guidance on pipeline removal and installation, refer to Annex 4.2.4.6 Liquid Cooling Pipeline Installation.

### **Annex 6.4.3 Instructions for Liquid Replenishment After Equipment Replacement**

When the liquid cooling unit has a low liquid level alarm, the liquid cooling system should be replenished in a timely manner.

Note: During the liquid replenishment operation, try to keep the unit running for a longer time. Even the vacuum-assisted liquid filling method requires the system to run for a longer period during the debugging phase to facilitate exhaust.

The detailed operation steps are as follows:

1. Connect the quick plug of the handheld display harness to the display interface of the cooling system, and close the drain valve;



Figure Annex 6- 17 Liquid cooling unit display wiring and drain valve position

2. Turn left to tighten and close the exhaust valve on the cooling pipeline;



Figure Annex 6- 18 Exhaust valve position on the liquid cooling pipeline

3. Connect the external power supply plug of the cooling system;



Figure Annex 6- 19 Power supply plug position on the liquid cooling unit

4. First, power on the handheld display, then click  on the screen;



Figure Annex 6- 20 Liquid cooling unit display

5. One person holds the display screen to monitor the return water pressure value. When the return water pressure value reaches 2.5 bar, notify the colleague responsible for the air circuit connection to disconnect the air injection tube at the drain port (if the return water pressure value exceeds

2.5 bar, the pressure can be adjusted by slightly opening the drain port switch).

After completing the air injection, record the current time. After maintaining the pressure for 15 minutes, observe the decay range of the return water pressure value. A decay value of less than 0.3 bar is considered qualified (i.e., not lower than 2.2 bar). Record the airtight test data in the registration form (both the set value and the actual value need to be recorded).

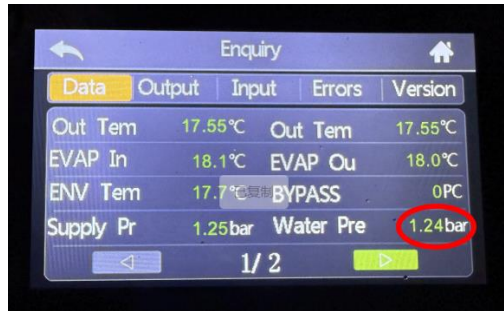

Figure Annex 6- 21 Display screen return water pressure

- After the airtight test is completed, slightly open the drain port to expel the gas in the pipeline in preparation for vacuuming. When the return water pressure value is observed to be 0, it indicates that the gas expulsion is complete.

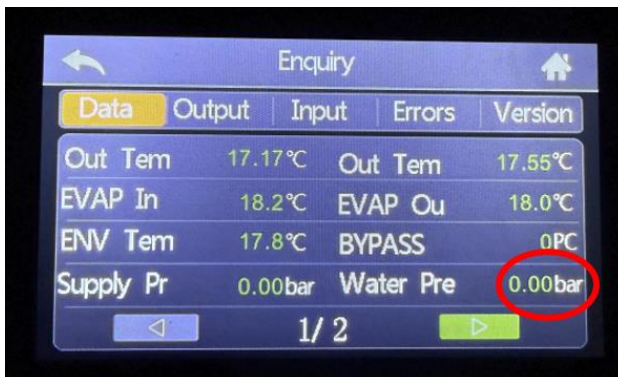

Figure Annex 6- 22 Complete exhaustion



Figure Annex 6- 23 Vacuum pump pressure

7. Connect the pipeline of the filling equipment to the filling port, and use the pipeline drain valve to discharge the air in the pipeline.



Figure Annex 6- 24 Connect both ends of the filling pump

8. While filling, exhaust simultaneously. Use a common 8mm transparent PU air tube inserted into the exhaust return valve to conduct. Place the other end of the return tube in the coolant container, start the circulation pump to circulate the coolant carrying free bubbles back into the container to complete the gas-liquid separator, and then inject it into the system by the filling pump, repeating this cycle.



Figure Annex 6- 25 Observe the liquid injection process

9. After starting the cooling system pump in manual mode, observe the supply and return water pressure under dynamic conditions. The pressure difference must be greater than 0.3 bar (maximum not exceeding 1 bar) when the pump is running dynamically to be qualified: Pressure calculation:  
Supply pressure - Return pressure > 0.3 bar;

If the pressure difference is less than 0.3 bar, run the pump for one minute and then turn it off, open the exhaust valve to vent, observe the static supply and return water pressure while venting, close the exhaust valve after venting is completed, and then run the pump for one minute, repeating this cycle until the dynamic pressure difference is greater than 0.3 bar.

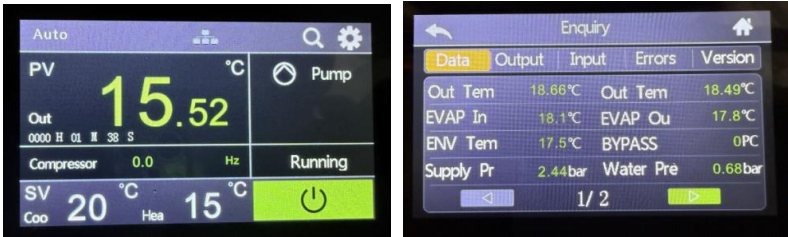

Figure Annex 6- 26 Observe liquid injection pressure

10. In manual mode, after starting the cooling system pump for one minute, the refrigeration compressor and fan will automatically start, which is normal. After the pump has been running for one minute, turn off the pump, open the exhaust valve, and observe the static pressure of the supply and return water (as shown in the figure below). The static pressure ranging from 0.6 bar to 1.2 bar (rounded to one decimal place) is normal. It is recommended to take the midpoint value. The maximum must not exceed 1.3 bar; otherwise, excess coolant must be drained through the drain port.



Figure Annex 6- 27 Observe liquid injection pressure

11. Disconnect the power strip, remove the external power cable harness and restore the original harness, remove the handheld display and cover the protective cover.

### Annex 6.4.4 Normal Operation and Maintenance Liquid Replenishment Operation Instructions

1. Use a pipeline to connect the liquid outlet of the replenishment pump to the liquid replenishment port of the liquid cooling unit, and connect the liquid inlet to the external liquid storage tank.
2. After connecting the power cord of the replenishment pump, power on the liquid cooling unit.
3. After opening the replenishment ball valve, start the replenishment pump to inject coolant.
4. Observe the return liquid pressure.
  - End the injection when the return liquid pressure is stable between 0.8 bar ~ 1 bar.
  - When the return liquid pressure is below 0.8 bar, continue to use the replenishment pump to inject coolant for pressurization.
5. After the injection is completed, close the ball valve behind the replenishment port and then remove the replenishment pump.

### Annex 6.5 Fire Safety System Maintenance Procedure

Table Annex 6- 4 Fire safety system maintenance procedure

Frequency	Category	Maintenance content	Remarks
Daily	Signboard Inspection	Check the warning signs in the protective area, including the warning signs for the manual pull starter, emergency stop switch, and manual-automatic transfer switch (emergency maintenance switch), to ensure they are in their original positions, securely installed, and not damaged.	
Monthly	Repeat	Repeat the contents of daily maintenance and inspection.	
	Equipment	Check whether all equipment	

	Sealing	maintaining the sealing of the protection area is intact, and linkage tests for linkage equipment such as fire dampers should be conducted every six months.	
Semi-annual	General inspection of aerosol devices	Check for any deformation, rust, aging, etc. on the appearance. Check whether the installation is secure.	
	Various detectors and alarms	Check if the working status is normal	
	All firefighting equipment	Ensure there are no changes that affect equipment performance. Check for changes in usage, environmental conditions, equipment location, physical obstructions, equipment orientation, physical damage, and cleanliness.	
Annual	Repeat	Repeat monthly maintenance and inspection.	
	Comprehensive inspection of aerosol devices	Inspect the structure of the battery compartment protected by the aerosol fire extinguishing system to determine whether any adverse effects such as fire extinguishing agent leakage or changes in the protected volume have occurred.	
	Integrity of the protected area	Investigate whether the protected area matches the originally designed system protection area and whether the integrity of the protected area has been	

		compromised.	
	Actuator	Check whether the functions of the electromagnetic actuator and mechanical actuator are intact.	
	Detector	Check all detectors to ensure they are in their proper positions, clean, and undamaged. Each detector should be tested according to the commissioning requirements. If necessary, test the sensitivity of each detector according to the manufacturer's procedures.	
	Each warning device	Check each buzzer, flashing light, and alarm bell. Check the alarm status and verify that they operate correctly when powered on. Reset the alarm circuit after testing each alarm device.	



## Annex 6.5.1 Fire Safety System Equipment Replacement Steps

Before replacing the liquid cooling unit, the system power should be disconnected. Refer to the previous section for the operation process.

### Annex 6.5.1.1 Smoke Detector Replacement

1. Record the cable connection position on the smoke detector, then remove the cable terminal.
2. Hold the smoke detector and rotate it counterclockwise to separate it from the base.

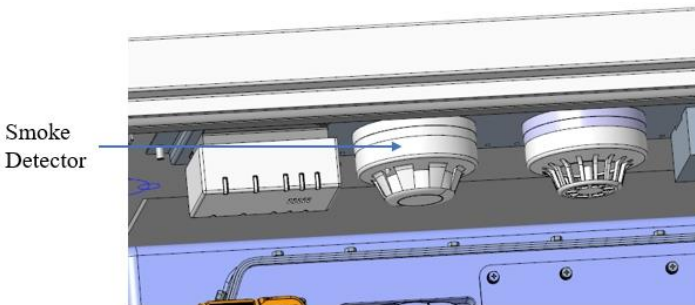

Figure Annex 6- 28 Smoke detector installation position

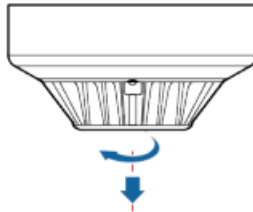

Figure Annex 6- 29 Remove smoke detector

3. Replace the new smoke detector and rotate it clockwise until it locks into place.
4. Connect the cable terminals to the new smoke detector according to the recorded information.

### Annex 6.5.1.2 Replace the Temperature Sensor

1. Record the cable connection position on the temperature detector, then remove the cable terminals.

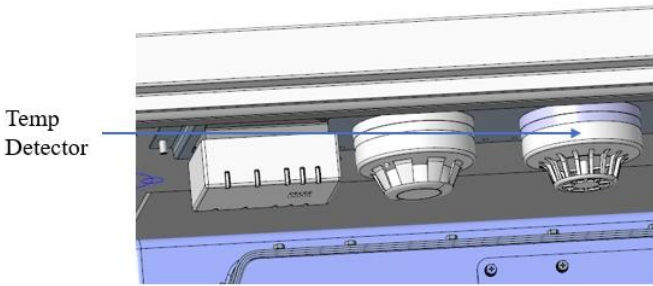

Figure Annex 6- 30 Temperature sensor installation position

2. Hold the temperature detector and rotate it counterclockwise to separate it from the base.

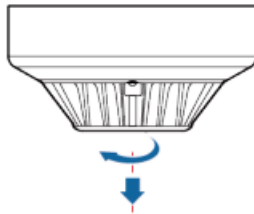

Figure Annex 6- 31 Remove temperature sensor

3. Replace the new temperature sensor, rotate the sensor clockwise until it locks into place.
4. Connect the cable terminals to the new temperature sensor according to the recorded information.

### Annex 6.5.1.3 Replace the Combustible Gas Detector

1. Record the cable connection positions on the combustible gas detector, then remove the cable terminals.

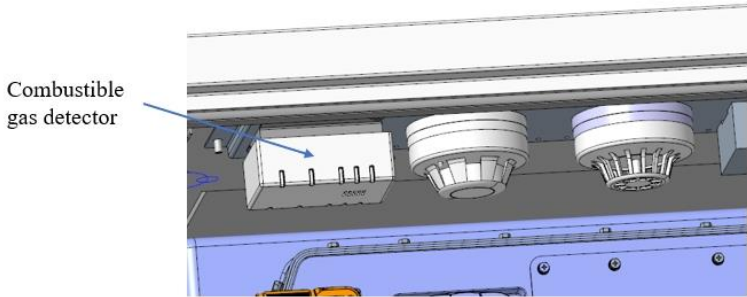

Figure Annex 6- 32 Combustible gas installation location

2. Hold the combustible gas detector, use a torque gun to remove the fixing screws of the combustible gas detector, and separate it from the base.
3. Remove the fixing screws of the combustible gas detector

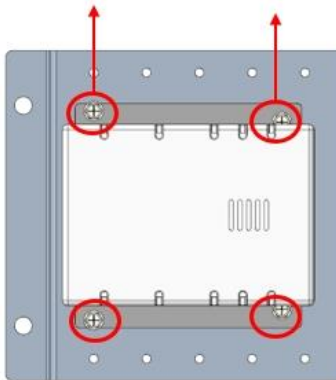

Figure Annex 6- 33 Remove the fixing screws of the combustible gas detector

4. Take out the combustible gas detector

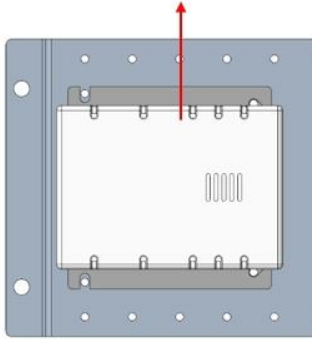

Figure Annex 6- 34 Remove the combustible gas detector

5. Replace the new combustible gas detector, and use a torque gun to secure the fixing screws of the combustible gas detector.
6. Connect the cable terminals to the new combustible gas detector according to the recorded information.

### Annex 6.5.1.4 Replace the Fire Extinguishing Device

1. Record the cable connection positions on the fire extinguishing device, and then remove the cables.

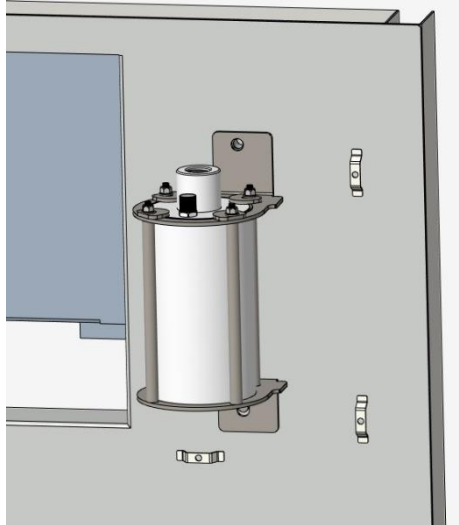

Figure Annex 6- 35 Fire extinguishing device installation location

2. Remove the old fire extinguishing device.

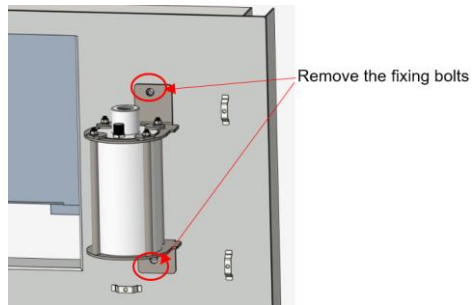

Figure Annex 6- 36 Remove fire extinguishing device

3. Install the new fire extinguishing device.
4. Install the cables to the new fire extinguishing device according to the recorded information.

## Annex 6.6 PCS Maintenance Procedure

- There is high voltage in the live parts of the PCS. Touching live parts may result in death or severe electric shock damage.
- Wear appropriate Personal Protective Equipment (PPE) during maintenance.
- Do not touch any live parts.
- Review all warning messages in the product and documentation.
- Please comply with all safety information provided by the battery manufacturer.
- Before performing any operations on the PCS, be sure to disconnect the external power supply equipment from the PCS:
  - Grid voltage of the grid feed
  - Internal power supply
  - Direct Current (DC) voltage of the battery
  - Additional external voltage, such as control signals from the control room.
- Ensure that disconnected devices cannot automatically reconnect.
- After turning off the device, wait at least 5 minutes before turning it on again to allow the capacitors to fully discharge.
- Before operating, ensure that all components are completely free of voltage.
- Cover or isolate any adjacent live components.
- More frequent maintenance may be required, with the specific maintenance frequency depending on the on-site conditions.
- If the DC distribution components are susceptible to harsh environmental conditions, it is recommended to shorten the maintenance intervals.
- It is recommended to conduct regular visual inspections to determine whether maintenance is required.

- If the PCS has not been in operation for an extended period (more than 6 months), an EEPROM fault may occur during the first power-up. Such faults can be cleared by following the steps below:
  - a. Disconnect all power connections to the PCS.
  - b. Wait for at least 30 seconds.
  - c. Reconnect the power supply and power on. This process can reinitialize the device, thereby clearing the EEPROM fault.
- For converters that have not been in operation for a long time, it is recommended to perform a capacitor activation operation before putting them back into use to ensure the normal operation of the equipment. The steps for capacitor activation are as follows:
  - a. Start the converter.
  - b. Issue a charging power command of 1kW.
  - c. Let the PCS operate at this power for 30 minutes.

This operation helps restore the performance of the capacitor and ensures stable operation of the PCS.

### Annex 6.6.1 Daily Inspection Items

Daily inspection items should follow the key points below:

No.	Daily Inspection Items	Confirm
1	The input and output voltage and current of the PCS, as well as its operating status, need to be monitored in real-time. Designated personnel should observe at fixed points. If any abnormalities in the converter's operation or voltage/current are detected, timely maintenance should be performed.	
2	Listen to the PCS for any abnormal noises.	
3	No abnormal odor is detected inside the PCS.	
4	Read the internal temperature of the PCS and observe that the temperature is within the normal range.	

### Annex 6.6.2 Regular Inspection Items

The quarterly inspection every three months mainly focuses on areas that are difficult to inspect during daily checks and routine operations.

No.	Regular Inspection Items	Confirm
1	Check the appearance of the PCS for no damage or rust.	
2	Use a temperature measuring instrument to detect that the internal temperature of the PCS is normal.	
3	Check that the ventilation, ambient temperature, humidity, dust, and other environmental conditions around the PCS meet the requirements.	
4	Check for aging or damage in the cable insulation layer. If found, add corresponding insulation measures or replace the cable.	
5	Check the wiring bolts for signs of aging or burning, and manually shake them to confirm they are in a tightened state.	

Attention:

For detailed maintenance procedures, please refer to the PCS user manual.



### Annex 6.6.3 PCS Replacement Steps

Before replacing the PCS, please confirm the following items:

- The system AC circuit breaker is turned off
- The system DC switch is turned off

Then follow the steps below:

1. As shown in the figure below, remove the PCS external DC cables (1), communication network cables (2), control cables (3), AC cables (4), grounding wires (5), etc.;



Figure Annex 6- 37 Remove the external connection lines of the PCS

2. Use a No. 2 screwdriver to unscrew the 4 screws on both sides of the PCS handle, pull the PCS out to the stop position, and then pull it out smoothly.

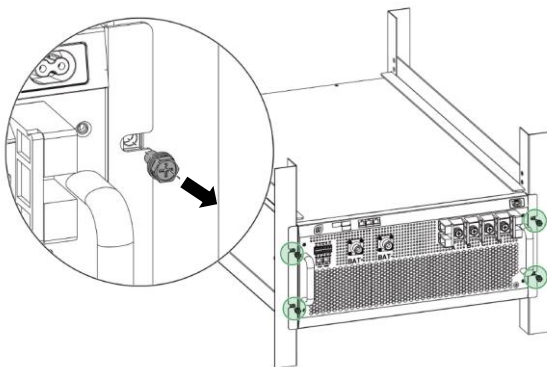

3. Install the new PCS and fixing screws, AC connection cables, and DC connection cables.
4. After the PCS is powered on again, connect to the PCS operation interface with the upper computer for program verification or update.

## Annex 6.7 Dehumidifier Maintenance Procedure

Table Annex 6- 7 Dehumidifier maintenance procedure

Frequency	Category	Maintenance standard	Detection method	Handling method
Annual	Reliable operation of the fan.	The fan blades are intact and rotating. The fan operates smoothly without abnormal noise.	Visual inspection	After power off for 10 minutes, check the fan for tightness and check if there are any internal cables or other obstructions interfering with the fan rotation. If the fan is faulty, please replace it.
	Wiring	Check for looseness	Visual inspection	After powering off for 10 minutes, check if the wiring has become loose.

## Annex 6.8 Power Distribution Component Maintenance

- UPS replacement
  - a. Power off the integrated cabinet, refer to section 6.1 Operational Procedures for C&I Integrated Cabinet;
  - b. Unplug the UPS power supply socket and battery PACK wiring;

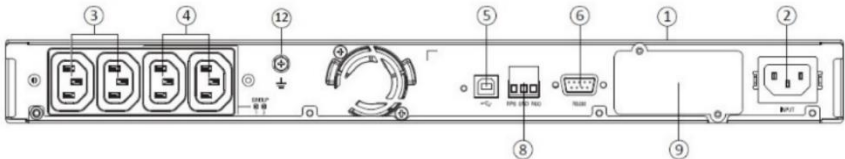

Figure Annex 6- 38 UPS rear view

- c. Remove the UPS front mounting bolts and pull out the UPS;



Figure Annex 6- 39 UPS front view

- d. Replace the new UPS, insert it into the original position, install the fixing bolts, and connect the incoming and outgoing lines;
- e. Power on and set the UPS voltage and frequency parameters to match the project requirements;
- f. Check for any missing or uninstalled accessories, etc.;
- Molded Case Circuit Breaker Replacement
  - a. System power off, refer to section 6.1 Operational Procedures for C&I Integrated Cabinet;
  - b. Remove the connecting wires on the distribution box and mark them;

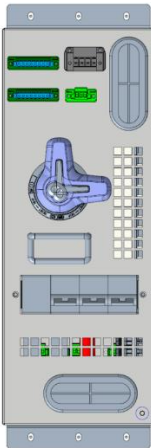

Figure Annex 6- 40

Front view of the distribution box

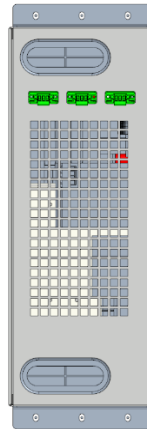

Figure Annex 6- 41

Rear view of the distribution box

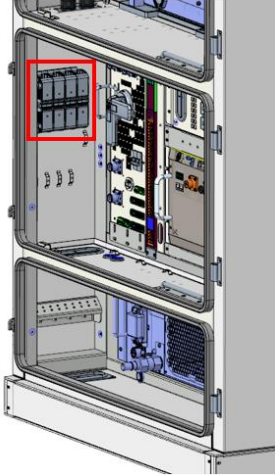

Figure Annex 6- 42 400V inlet terminal

- c. Remove the screws on the sheet metal fixture and pull out the distribution box.

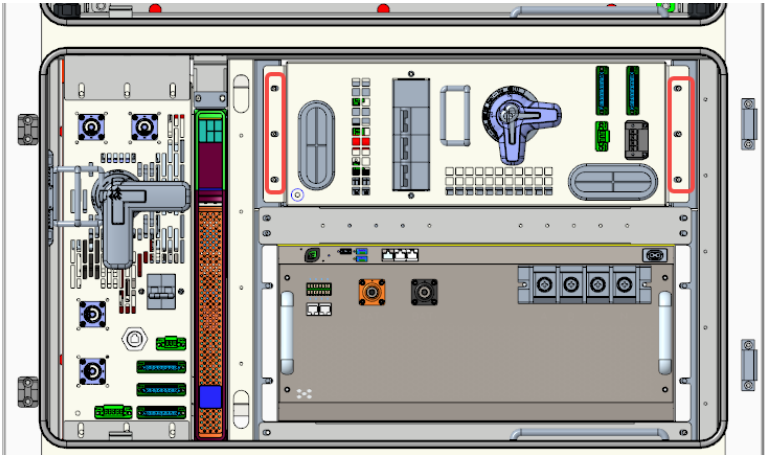

Figure Annex 6- 43 Front protective plate of the circuit breaker assembly

- d. Remove the fixing screws on the cover plate of the distribution box and take off the cover plate;

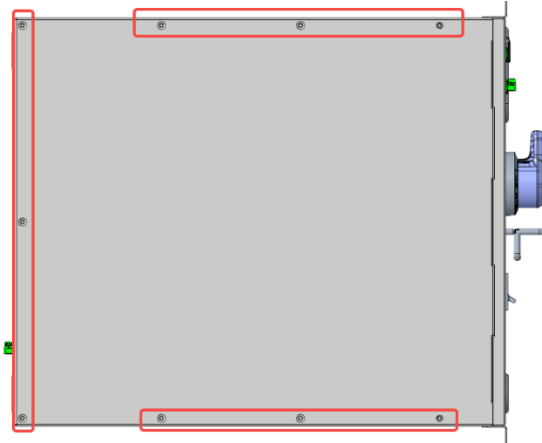

Figure Annex 6- 44 Remove the fixing screws on the cover plate of the distribution box

- e. Remove the copper busbar and connecting cable connected to the circuit breaker, and mark them;

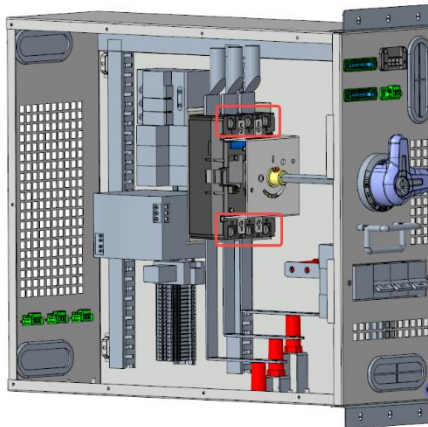

Figure Annex 6- 45 Remove the copper busbar and cable connected to the circuit breaker

- f. Remove the fixing bolts of the circuit breaker and remove the circuit breaker;

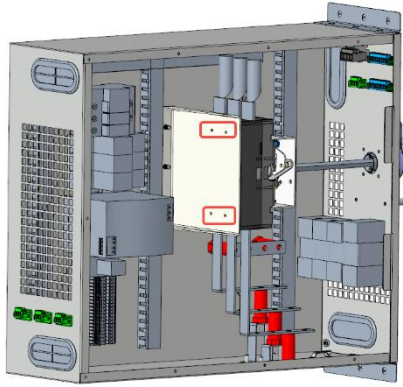

Figure Annex 6- 46 Remove the fixing bolts of the circuit breaker and remove the circuit breaker

- g. Replace the new circuit breaker and restore the connecting copper busbar and cable;
  - h. The distribution box is installed in place and wired;
- Replace the switching power supply, miniature circuit breaker, energy meter, etc., following the same steps as above.

## Annex 6.9 Replacement of High Voltage Box Components

1. Power off the system, refer to section 6.1 Operational Procedures for C&I Integrated Cabinet;
2. Remove all external cables and mark them;

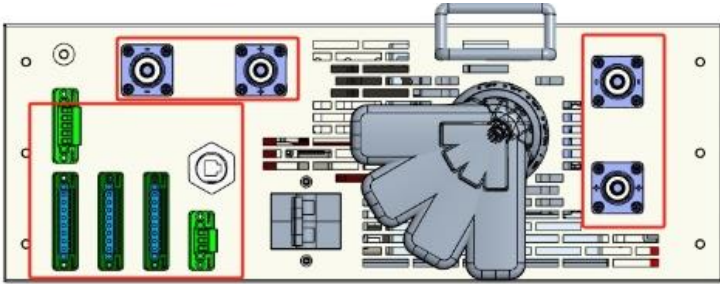

Figure Annex 6- 47 High voltage box panel wiring diagram

3. Use tools to unscrew the fixed screws, pull out the high voltage box, and open the cover of the high voltage box;

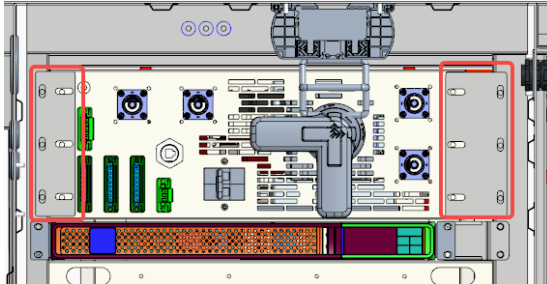

Figure Annex 6- 48 High voltage box panel fixing screws

4. Remove the old disconnecter, fuse, ESBCM, etc. as shown in Figure 3-14;
5. Install new disconnecter, fuse, ESBCM, etc.;
6. Install the upper cover of high voltage box;
7. Connect the cables according to the electrical diagram and cable labels;

## Annex 6.10 Cooling Fan Maintenance

The cooling fan of the equipment compartment is installed on the backplane of the integrated cabinet. For daily maintenance, refer to the manual of PCS. If replacement is needed, the operation steps are as follows:

1. Use a torque gun to remove the 12 hexagon socket combination screws (red circles in the figure below) of the cabinet, with a torque of  $5.9 \pm 0.2$  N·m.

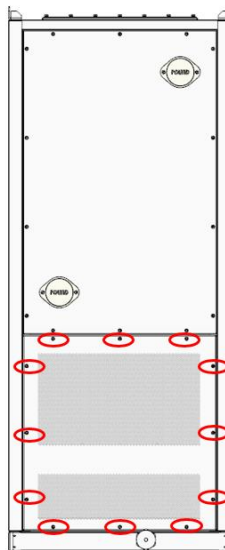

Figure Annex 6- 49 Remove equipment compartment backplane

2. Cut the cable ties of the axial fan and temperature control switch harness, use a torque gun to remove the assembled axial fan mounting plate from the back sheet metal of the cabinet, and remove the M5\*12 combination screws (red circles in the figure below) with a torque of  $3.4 \pm 0.2$  N·m.

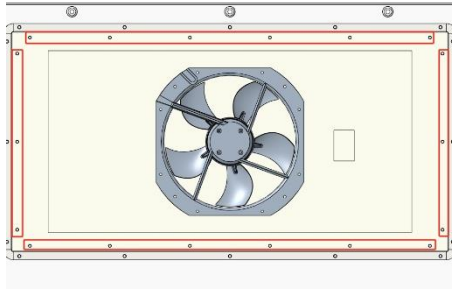

Figure Annex 6- 50 Fixing holes of the cooling fan mounting plate

3. Remove the wiring on the fan, use a torque gun to remove the 8 M6X16 combination screws (red circles in the figure below) that fix the axial fan to the mounting plate, with a torque of  $5.9 \pm 0.2$  N·m. Use a torque gun to remove the 4 M6X20 combination screws (yellow circles in the figure below) that fix the axial fan filter to the fan, with a torque of  $5.9 \pm 0.2$  N·m .

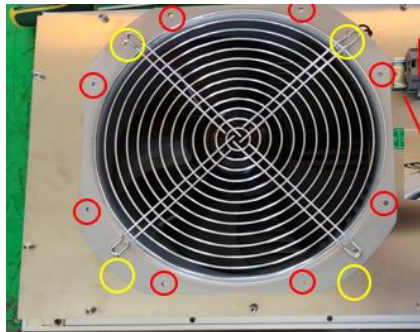

Figure Annex 6- 51 Heat dissipation fan fixing holes and fan filter fixing holes

4. Take a new heat dissipation fan, perform steps 3~1, and complete the installation of the heat dissipation fan, fan filter, fan mounting plate, and cabinet backplate.

## **Annex 6.11 UPS Maintenance Procedure**

### **Annex 6.11.1 Equipment Maintenance**

To ensure the smooth progress of preventive maintenance, please keep the area around the equipment clean and dust-free. If there is a lot of dust in the atmosphere, use a vacuum cleaner to clean the exterior of the equipment.

To fully utilize the battery's lifespan, it is best to maintain the device's ambient temperature at 25°C (77 °F).

The rated lifespan of the battery is 3-5 years. The actual lifespan depends on the frequency of battery usage and the ambient temperature (in environments above 25 °C, the lifespan is halved for every 10°C increase).

If the UPS needs to be moved, please ensure that the UPS is powered off.

Typically, batteries that exceed their expected lifespan will significantly reduce runtime. Replace the battery at least every 4 years to ensure the device operates at peak performance.

Under low-temperature conditions (below 10°C), the remaining battery time will decrease.

### **Annex 6.11.2 Storage Equipment**

If you need to store the equipment for a long time, please connect the UPS to the grid at least once every 6 months to charge the battery. The internal battery charges to 90% capacity within 3 hours. However, Eaton recommends that the battery should be charged for 48 hours after long-term storage.

Please check the battery charging date on the carton label. If the date has passed and the battery has never been charged, do not use the UPS. Please contact your service representative.

## **Annex 6.12 Circuit Breaker Maintenance Procedure**

### **Annex 6.12.1 Circuit Breaker Maintenance**

The maintenance cycle of the circuit breaker is usually recommended by the manufacturer, generally once a year, but it may also be adjusted according to the operating environment and conditions. The following items should be noted during maintenance:

1. **Check appearance:** Check whether the circuit breaker has cracks, deformation, or other damage.
2. **Cleaning:** Remove dust and dirt to prevent overheating or poor contact.
3. **Check wiring:** Ensure the wiring is secure, without looseness or corrosion.
4. **Test operation:** Test whether the circuit breaker can operate smoothly and whether the trip and reset functions are normal.
5. **Check trip records:** Record the number of trips and the reasons, analyze if there are potential issues.
6. **Safety measures:** Take appropriate safety measures during maintenance, such as turning off the power, using insulated tools.

Regular maintenance can extend the service life of the circuit breaker and ensure it provides necessary protection at critical moments.

## Annex 6.12.2 Miniature Circuit Breaker Replacement

The steps for replacing a miniature circuit breaker are as follows:

1. First, ensure that the power is turned off, use a screwdriver to loosen the cross screws of the circuit breaker, and then disconnect the wiring tab from the circuit breaker.

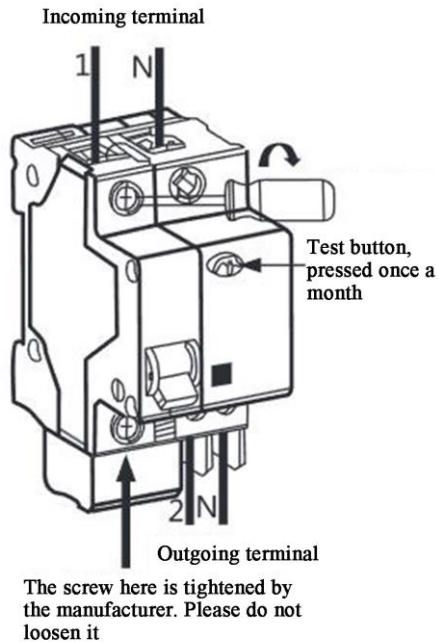

Figure Annex 6- 52 Circuit breaker

- Place the new circuit breaker in the original position, ensuring that the circuit breaker is aligned with the mounting plate or rail. Then, insert the wiring tab into the blade socket of the circuit breaker and secure it with a nut or bolt.

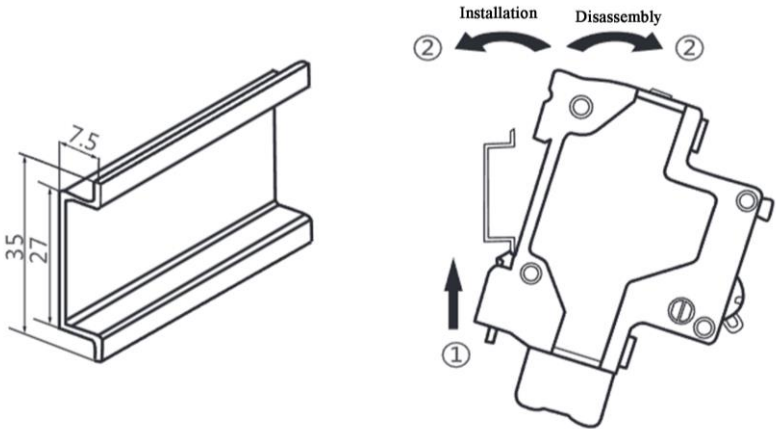

Figure Annex 6- 53 Circuit breaker replacement

- According to the original wiring diagram, connect the wires of the original circuit to the new circuit breaker in sequence, ensuring that the connections are secure and reliable. Use an electric screwdriver or torque wrench to tighten the wiring bolts or nuts one by one.
- After completing the circuit breaker replacement, restore the power supply and perform functional testing of the circuit breaker. By operating the switch, verify whether the closing and opening functions of the circuit breaker are normal.

## **Annex 6.13 Cabinet Maintenance**

The product appearance should be kept intact. If there is paint peeling, it should be repainted immediately. Visually inspect the extent of paint damage on the product, prepare the corresponding tools and materials, and assess the quantity of materials on-site based on the repainting situation.

Check the appearance damage and select the appropriate solution based on different levels of damage.

- Solution 1: Surface dirt can be wiped off
- Solution 2: Surface dirt cannot be wiped off
- Solution 3: Primer damage exposes the substrate

### **Operation steps of Solution 1**

1. Prepare tools and materials: cloth, water, alcohol or other non-corrosive cleaners.
2. Use a cloth (or other scrubbing tool) dipped in water to scrub the dirty areas of the surface; use a cloth (or other scrubbing tool) dipped in water to scrub the dirty areas of the surface.

### **Operation steps of Solution 2**

1. Prepare tools and materials: sandpaper, cloth, water, alcohol, zinc-rich primer, brush, and paint with the corresponding color number of the cabinet.
2. Use sandpaper to sand the areas where the surface paint is raised or scratched to make the surface smooth.
3. Use a cloth dipped in water or 97% alcohol to scrub the damaged areas to remove surface stains.
4. After the surface is dry, use a soft brush to touch up the paint on the scratched areas, and try to keep the paint application as even and consistent as possible.

**Operation steps of Solution 3**

1. Prepare tools and materials: sandpaper, cloth, water, alcohol, brush, and cabinet paint with the corresponding color code.
2. Gently sand the damaged area with fine sandpaper to remove dirt or rust.
3. Moisten a cloth with anhydrous ethanol and wipe the sanded or repair area to remove surface dirt and dust, then dry it with a clean cloth.
4. Use a brush or spray gun to apply zinc-rich primer to the damaged coating area.
5. Depending on the degree of paint damage, choose one method from spray paint, brush paint, or spray gun application to evenly touch up the damaged coating area until the damage marks are no longer visible.
6. After painting, let it sit for about 30 minutes, then observe whether the touched-up area meets the requirements.

**Shanghai CHINT Power Systems Co., Ltd**

Headquarters: No.5999, Guangfulin Road, Songjiang District, Shanghai, 201616,  
China

Switchboard: +86-21-37791222-866000

Fax: +86-21-37791222-866001

Website: [www.chintpower.com](http://www.chintpower.com)

Service Hotline: +86-21-37791222-866300

Email: [service.cps@chint.com](mailto:service.cps@chint.com)

The above information is subject to change without prior notice.

Any unauthorized copying and plagiarism are prohibited.