

ECH8/10/12/15/18/20K-TH-EU Series Three-phase Energy Storage Inverter User Manual

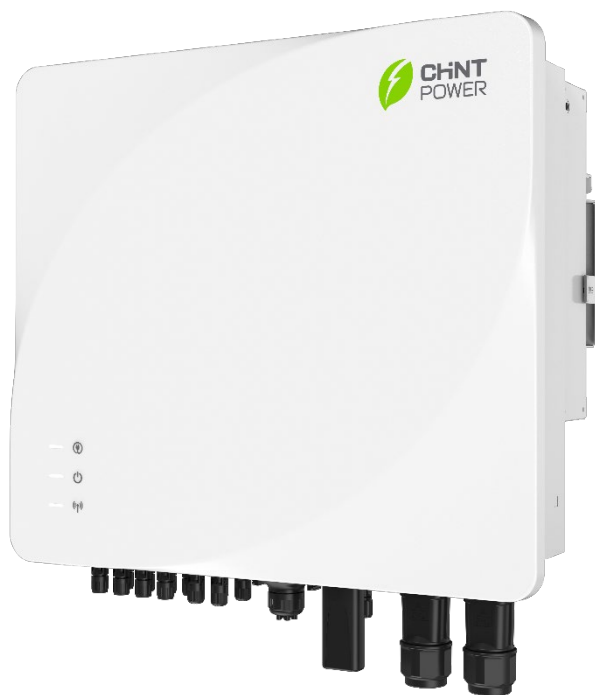

Shanghai Chint Power Systems Co., Ltd.

Revision: 3.0 Date: October 2025 Doc No.: 9.0020.0897C0

Revision History

Revision	Update	Date
Rev1.0	Initial released	2024.08
Rev1.1	Improved troubleshooting table Improved smart load schematic diagram Improved product model Improved working mode description	2024.10
Rev1.2	Deleted detailed Web &APP	2024.11
Rev1.3	Improved wire range and LED desc.	2024.12
Rev1.4	Added AC Coupling	2025.6
Rev2.0	Updated section 4.8 crimping plier type	2025.7
Rev2.1	Updated battery cable specification	2025.7
Rev2.2	Updated fig 4-29 &30&4-39	2025.8
Rev3.0	Updated Sec. 4.4 & 4.13	2025.9
Rev3.0	New Section 4.18 Generator Function Update 5.3.1 Self-Powered Mode	2025.10

Table of Content

0.	Preface	6
1.	Safety Instructions.....	8
1.1	Definition of Symbols in this Manual.....	8
1.2	Interpretation of Product Markings.....	9
1.3	Precautions for Equipment Safety	10
1.4	Safety Responsibilities	11
1.4.1	Safety Responsibilities of the Owner.....	11
1.4.2	Safety Responsibilities of O&M Personnel	12
1.5	Requirements for Safe Operation	13
1.5.1	Safety Markings.....	13
1.5.2	Safe Operation	13
2.	Overview	15
2.1	Model meaning.....	15
2.2	Product Appearance Components and Dimensions	16
2.3	Functional Features.....	18
2.4	LED Indicator.....	19
2.5	System Scheme Diagram	20
3.	Product Installation.....	21
3.1	Product Installation Process	21
3.2	Device Check	22
3.2.1	Arrival Check.....	22
3.2.2	Delivery List Check.....	22
3.3	Environment Selection.....	24
3.4	Installation Tools	26
3.5	Inverter Installation	27
4.	Electrical Connection	30
4.1	Safety Instructions	30
4.2	Port and Cable Specifications	31
4.3	Inverter Cable Specifications.....	32
4.4	Tools and Torques	32
4.5	Electrical System Wiring Diagram	33
4.6	Protective Grounding Cable Connection	35
4.7	GRID and BACK-UP (Load) Cable Connection	36
4.8	Battery Cable Connection.....	38
4.9	PV Cable Connection	39
4.10	Communication Cable Connection	42
4.10.1	Definitions of signal pins.....	42
4.10.2	External Communication Cable Connection.....	46
4.11	COM Module Installation	48

4.12	Parallel connection function.....	48
4.13	LOAD CNTL Cable Connection	52
4.14	DRM Connection	55
4.14.1	DRM	55
4.14.2	Ripple Control.....	57
4.15	External Rapid Shutdown Device (RSD)	58
4.16	AFCI (Arc-Fault Circuit-Interrupter) protect function	59
4.17	AC Coupling Function.....	60
4.18	Generator Function.....	61
5.	Inverter Commissioning	66
5.1	Pre-commissioning Checks and Preparation.....	66
5.1.1	Inverter Installation check.....	66
5.1.2	Cable connection check	66
5.1.3	Electric connection check.....	66
5.2	Power on/off steps.....	66
5.3	Operating Mode.....	67
5.3.1	Self-Powered Mode.....	68
5.3.2	Fully Fed Mode.....	70
5.3.3	Emergency Charging Mode.....	70
5.3.4	Forced Off-Grid Mode.....	71
5.3.5	Pure PV Mode	72
5.3.6	TOU.....	73
6.	App Local Control.....	74
6.1	App Download	74
6.2	App Connection and Setting.....	75
7.	App Remote Control	84
7.1	Sign up and Login.....	84
7.2	Site	87
7.2.1	Create Site	87
7.2.2	AC Coupling.....	91
7.2.3	Generator	93
7.3	Application – Remote Upgrade.....	95
7.4	Account	98
8.	Cloud Platform Introduction	99
8.1	System Login.....	99
8.1.1	Registration and Login	99
8.2	Account Management.....	101
8.2.1	Add Company.....	101
8.2.2	Add User	102
8.3	Site Management	103
8.3.1	Site	103

8.3.2	Inverter	106
8.4	Upgrade.....	108
8.4.1	Firmware Upgrade.....	108
9.	Fault and Maintenance	110
9.1	Fault Analysis and Troubleshooting.....	110
9.2	Fault Maintenance	123
9.2.1	Inverter Power-off.....	123
9.2.2	Inverter Removal	123
9.3	Routine Maintenance.....	124
10.	Technical Data	126
11.	Quality Assurance.....	130
11.1	Liability exemption	130
11.2	Warranty Clauses	131
12.	Recycling	132

0. Preface

Thank you for choosing CHINT energy storage grid-connected inverter (hereinafter referred to as "energy storage inverter" or "inverter" in this manual) developed by Shanghai Chint Power Systems Co., Ltd (hereinafter referred to as "CHINT").

These energy storage inverters feature an innovative design and perfect quality control, ensuring high reliability quality and making them suitable for high-standard grid-connected systems.



IMPORTANT!

Please read this manual carefully and make sure that you have understood all the contents thoroughly before you start any operation.

Main Contents

This Installation and Operation manual contains important information, safety guidelines, detailed planning, and setup information for installation, as well as information about configuration, operation, and troubleshooting. Be sure to read this manual carefully before using.

Target Readers

- Plant owner
- Project Engineer
- Installation engineer
- Maintenance engineer

Installation, commissioning, troubleshooting, and maintenance of the inverter must be done only by qualified personnel. If you encounter any problems during the above-mentioned operation, please check the user manual carefully. You can also contact your local dealer or supplier for help if the problem still exists.

This manual describes important information about product installation and safe operation. Please read it carefully before use.

Manual Management

Please keep this user manual on hand for quick reference.

Copyrights

CHINT reserves all rights in this manual. Any reproduction, disclosure or copy in whole or in part is forbidden without prior written authorization. CHINT doesn't accept any responsibilities whatsoever for potential errors or possible lack of information in this document.

Version

This manual is subject to change or modification without prior notice. Users can get the latest manual from our sales channel or our official website: www.chintpower.com.

1. Safety Instructions

Please read this manual carefully before installation. If the equipment is damaged because of failing to following the instructions in this manual, we reserve the right not to provide quality assurance!

1.1 Definition of Symbols in this Manual

**DANGER:**

There is a high-level potential danger that, if not avoided, may result in death or serious injury to personnel.

**WARNING:**

There is a moderate potential danger that, if not avoided, may result in death or serious injury to personnel.

**CAUTION:**

There is a low-level potential hazard that, if not avoided, may result in moderate or mild injury to personnel.

**NOTICE:**

There is a potential risk that, if not avoided, may result in the equipment not functioning properly or causing property damage.

**IMPORTANT:**

Additional information in this manual that highlights and supplements the content and may also provide tips for optimizing product use so it can help solve problems or save you time.

1.2 Interpretation of Product Markings

**Electric Shock Hazard:**

There is a high voltage inside the body. Therefore, follow this manual when operating this product.

**High Temperature:**

This product complies with international safety standards, but it generates heat during operation. Therefore, never touch the cooling fin or the metal surface of the inverter during operation.

**Hazardous Energy:**

The electrical energy stored in capacitors may pose a risk of electric shock.

Wait for 5 minutes after disconnecting all power supplies before removing the upper cover.



For more details, see the user manual.

**Warning:**

FUSES FOR REPLACEMENT MUST BE OF THE SAME MODEL AND RATING TO MAINTAIN SUSTAINED FIRE RESISTANCE. FOR DETAILS, SEE THE USER MANUAL.

**Protective Earthing:**

This marking is located at the protective earthing (PE) terminal, requiring a solid earthing to ensure the safety of operators.

**RoHS:**

The inverter complies with 2011/65/EU which specifies the

restrictions on the use of specific harmful substances in electronic and electrical equipment.

**CE:**

The inverter complies with EU regulations and standards.

**TUV:**

The safety and quality of the inverter have been certified by TÜV SÜD.

1.3 Precautions for Equipment Safety

DANGER:

Before opening the inverter housing for maintenance, disconnect AC power and DC power, and ensure that the HV energy inside the equipment has been fully released!

Generally, you can maintain and operate the equipment at least 5 minutes after all connections of the inverter are cut off.

**WARNING:**

All operations and connections shall be completed by professional engineering and technical personnel!

When the PV panel is exposed to sunlight, a DC high voltage will be generated in the PV terminals of the inverter. To prevent the risk of electric shock during equipment maintenance or installation, please ensure that all DC (including PV and battery) and AC power have been disconnected from the equipment, and ensure that the equipment is reliably earthed.

Be careful, the PECS provide bypass connection. All external AC grid, PV or battery power shall be disconnected before maintaining.

**CAUTION:**

Check the wall bracket again before hanging the machine to ensure

that it is firmly secured on the support surface.

**NOTICE:**

Do not install the inverter in a place exposed to direct sunlight, to avoid reduction of conversion efficiency caused by high temperature and ensure long-term service life of the inverter.

IMPORTANT:

Before choosing the grid code, contact your local power supply company. If the inverter is set to work under a wrong grid code, the power supply company may cancel the operating license for that equipment.

Ensure that the whole system complies with national standards and applicable safety regulations before operating the inverter.

1.4 Safety Responsibilities

Please read the safety instructions in this chapter carefully before installing and using the energy storage inverter. We will not be liable and provide quality assurance if personal injury or equipment damage is caused as a result of failing to follow the safety instructions in this manual!

1.4.1 Safety Responsibilities of the Owner

When operating and maintaining the energy storage inverters, you need to pay attention to relevant safety precautions. Owner must comply with the following requirements:

1. Operators must be trained and qualified electrical workers. Otherwise, they cannot operate the energy storage inverter. Improper or incorrect operation may cause serious harm to operators;
2. Operators shall be fully familiar with the working principle of energy storage inverters;
3. Operators shall be fully familiar with this manual;
4. Operators shall be fully familiar with the local electrical regulations and standards;

5. Regularly inspect the safety equipment within the system to ensure its reliability;
6. Immediately replace any warning signs damaged or illegible on the equipment;
7. Do not store flammable and explosive articles nearby;
8. The wall surface for storing energy storage inverter products must be firm and reliable;
9. Transportation, installation, and commissioning can only be carried out by professional personnel recognized by the manufacturer;
10. Before operating the energy storage inverter, please evaluate the events that may cause system hazards and troubleshoot them;
11. This manual describes the safety instructions in details. Operators shall read it carefully for full understanding;
12. The software, housing, and internal components of the equipment cannot be changed without the manufacturer's approval. If these are any unauthorized changes, the quality assurance of the energy storage inverter becomes invalid;
13. The sealing strip on the equipment cannot be damaged. If it is damaged, the quality assurance of this equipment becomes invalid.

1.4.2 Safety Responsibilities of O&M Personnel

Qualified O&M personnel are persons who are trained to have the following necessary electrical knowledge:

1. Understand the installation, use, disassembly, earthing, short circuit, and maintenance of the product;
2. Evaluate the assigned tasks and spot possible hazardous events;
3. Provide immediate rescue for the injured;
4. Understand the relevant maintenance criteria of the product;
5. Observe local regulations and standards.

The O&M personnel must ensure that all the following safety requirements are met:

1. Before installation and commissioning, conduct step-by-step inspections

according to the safety instructions in this manual;

2. Before running the system, please confirm the system is complete and safe.
3. Before maintenance, use correct testing device to confirm the converter system is completely uncharged.

1.5 Requirements for Safe Operation

1.5.1 Safety Markings

When maintaining the energy storage inverter, to prevent incorrect operations caused by irrelevant personnel entering the site, please comply with the following regulations:

1. The safety warning signs on the energy storage inverter provide important information for safe operation, so they shall not be artificially damaged;
2. The nameplate on the energy storage inverter provides important information of relevant products, so they shall not be artificially damaged;
3. Obvious safety warning tapes are set up near the operation area.

1.5.2 Safe Operation

We shall observe following rules to use energy storage system in a safe way:

1. Only authorized staff can operate the energy storage inverter;
2. Check the energy storage inverter on before powering it on, to ensure that the system is ready and safe. If there is a possibility of danger, please do not power on the inverter;
3. Abide by regulations described in the manual during the inverter operation;
4. Do not disassemble any component when the system is running;
5. Start maintenance work at least 5 min after the energy storage inverter is powered off;
6. Disconnect all power supply and provided signs to prevent accidental closing before maintenance;
7. Check the components before maintenance to ensure that they are completely de-energized;
8. Assign at least two persons onsite during maintenance, one for operation

- and the other for ensuring safety;
9. Take insulation measures, such as wearing insulating gloves if the maintenance components will always be live;
 10. During maintenance, ensure that the AC and DC switches are disconnected and the power grid is disconnected;
 11. Never touch the battery electrode as short-circuit current of the battery module is very high. Otherwise, serious injury may be caused;
 12. Do not perform maintenance in rainy days, to avoid accidental water falling into the machine.

2. Overview

ECH series energy storage inverter is a three-phase energy storage inverter integrating PV grid-connected inverter and battery energy storage. It's built-in multiple working modes can meet the diversified needs of users. It can control and optimize the energy flow through an integrated energy management system. The power generated in the PV system can be used by loads, stored into the batteries, and output to the grid.

Energy storage inverters can provide complete solutions in the period of rising energy costs such as petroleum and coal, the period of decreasing energy subsidies for PV grid-connected systems, in mountainous areas or base stations without power grids, and in cases requiring UPS or emergency power.

2.1 Model meaning

This document takes ECH20K-TH-EU as an example to illustrate the meaning represented by each letter combination in a product model, as described in the following figure.

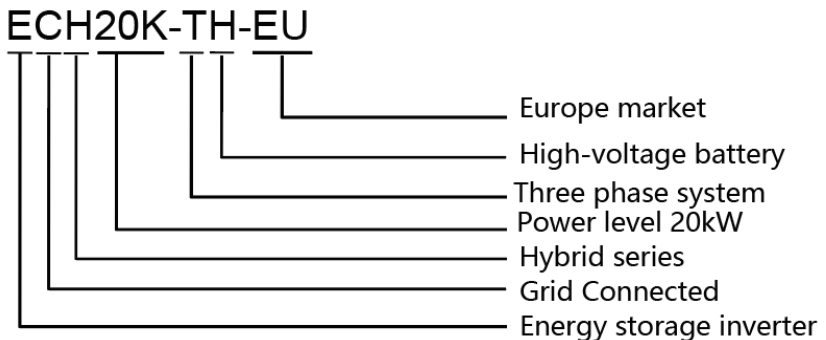

Figure 2-1: Meaning of Product Model

2.2 Product Appearance Components and Dimensions

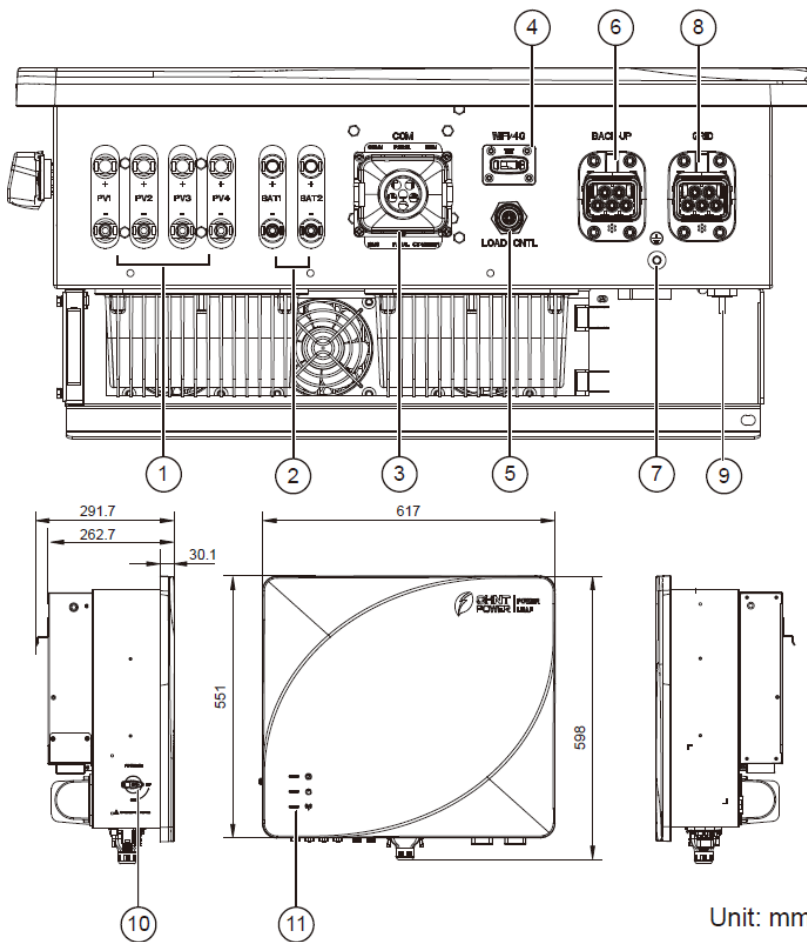

Figure 2-2 Product Appearance Components and Dimensions

S/N	Name	Function
1	PV input terminal	Connect DC cable
2	BAT terminal	Connect battery cable
3	COM port	External serial communication
4	WIFI/4G port	Connect WIFI/4G communication modules
5	Smart load control port	Connect smart load control cables
6	BACK-UP terminal	Connect load cable
7	External grounding hole	Protective grounding point
8	GRID terminal	Connect grid cables
9	Temperature probe	Measure ambient temperature
10	PV SWITCH	Power on/off PV power supply
11	LED indicator	Indicate the inverter status

Table 2-1 Product Appearance Components



2.3 Functional Features

ECH8/10/12/15/18K-TH-EU energy storage inverter allows up to 110% overload, maximizing support for high-power loads and support capacitive and inductive loads, such as motors, refrigerators, and air conditioners. The main functional features of this series of energy storage inverters are as follows:

- 4-channel independent MPPT inputs
- Wide series voltage range of PV panels (160-1100V)
- Automatic switching between flexible grid connection and off-grid modes
- Maximum PV grid efficiency up to 98.3%
- Maximum continues charging/discharging current up to 50A
- Parallel connection of multiple machines, making the system solution more flexible
- APP intelligent monitoring: RS485/WIFI/4G(optional)/Bluetooth
- Automatic derating operation in external high temperature and harsh environment
- Inverter integrated AFCI function
- Output short circuit protection
- Input earth insulation impedance monitoring
- Output voltage and frequency monitoring
- Earth leakage current monitoring
- Output current DC component monitoring
- Anti-islanding protection
- Input and output overvoltage protection
- Input overcurrent protection
- IGBT temperature monitoring
- Support external quick shutdown device
- Support external smart load control
- Support AC coupling
- Three-phase unbalance capability, maximum power of single phase is up to 50% rated power (For 20kW inverter, max. power of single phase is 9kW).

2.4 LED Indicator

The indicator in the lower left corner will light up. To help users to understand the working status and fault information of the inverter, the following table explains the operation state for each indicator light state. If an abnormal operation occurs, detailed fault information can be found in Table 9-1: Energy Storage Inverter Fault Information.

Indicator	Description	Status	Description
	AC output light	On (Green)	On-grid operation
		On (Yellow)	Bypass operation*
		Flash (Green)	Off-grid operation
		Off	Abnormal internal communication
		On (Red)	No output
	System light	On (Red)	Failure occurred
		On (Yellow)	Standby
		Flash (Yellow)	Module fault/Derating operation
		On (Green)	In normal running
		Flash (Green)	Pre-inspection
		Off	Abnormal internal communication
	Communication light	On (Red)	Abnormal internal communication
		Flash (Red)	Abnormal BMS communication
		Flash (Yellow)	Abnormal parallel CAN communication
		On (Yellow)	Abnormal meter communication
		On (Green)	All communication is normal

*Bypass operation: The inverter is in standby state, and power grid supplies power to loads.

Table 2-2 Indicator Description

2.5 System Scheme Diagram

The following is the system scheme diagram, which illustrates the overall configuration and connections of the system components.

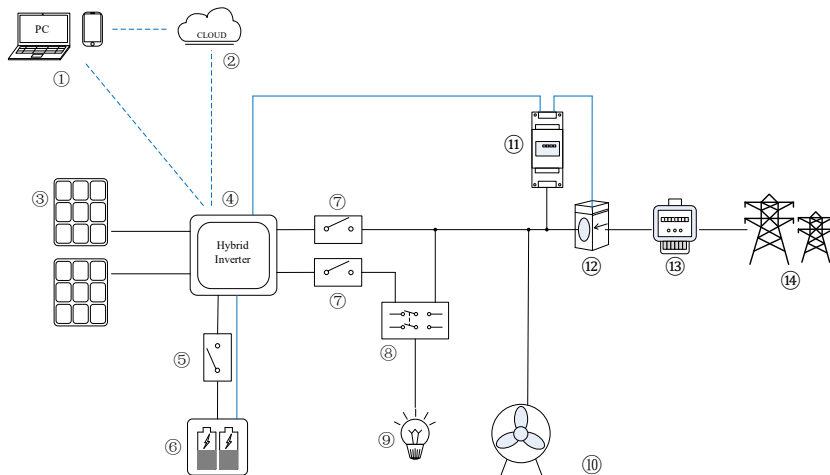

Figure 2-3 Structure of ECH Energy Storage Inverter

S/N	Name	S/N	Name
1	Smart device	8	Double -pole double-throw switch
2	Cloud	9	Back-up load
3	PV module	10	On-Grid load
4	Energy storage inverter	11	Smart meter
5	DC circuit breaker	12	CT
6	Battery pack	13	Household electric meter
7	AC circuit breaker	14	Power grid

Table 2-3 Structure Diagram of ECH Energy Storage Inverter

3. Product Installation

3.1 Product Installation Process

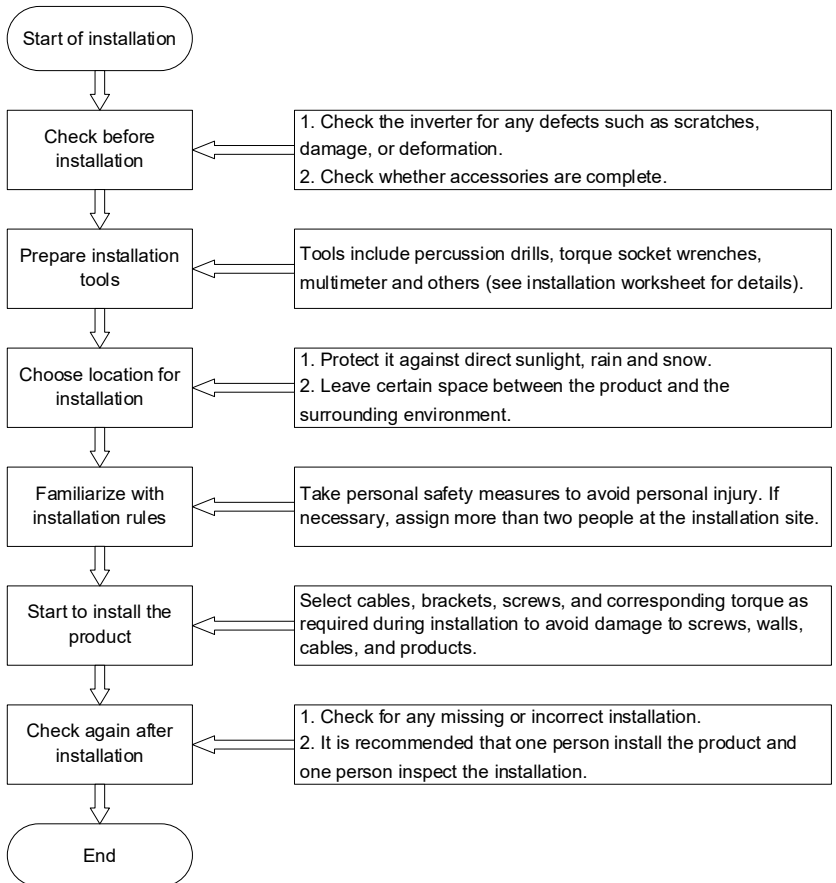

Figure 3-1 Schematic Diagram of Installation Process

3.2 Device Check

3.2.1 Arrival Check

The energy storage inverter has undergone detailed factory test before delivery and carefully checked by the staff. However, during transportation, there is still a possibility of equipment collision or even damage. So, after receiving the energy storage inverter, first check the integrity of the energy storage inverter transported. The check mainly includes the following items:

1. Check the outer packaging for any damage, such as deformation, holes, cracks, or other signs that may cause damage to the device inside. If there is any damage, do not unpack, and contact your dealer.
2. Check whether the inverter model is correct. If there is any discrepancy, do not unpack, and contact your dealer.
3. Check whether the type and quantity of deliverables are correct, and whether the appearance is damaged. If there is any damage, please contact your dealer immediately.

3.2.2 Delivery List Check

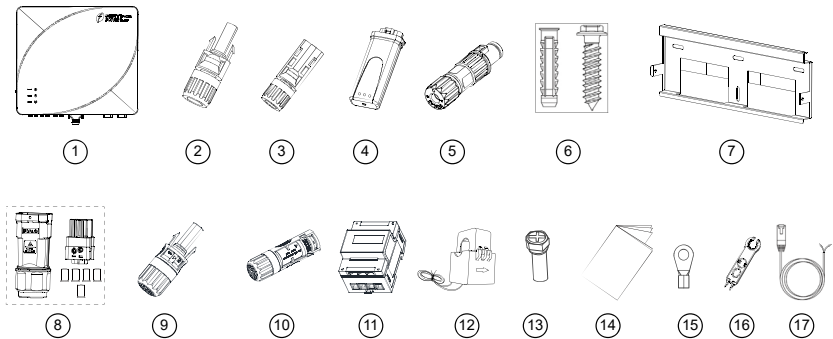

Figure 3-2 Scope of supply

No.	Name	QTY	Description
1	Inverter	1	Each MPPT of 8-20KW inverter only has one input string
2	PV+ connector	4	DC quick-plug connector
3	PV- connector	4	
4	COM module	1	Used for inverter communication
5	LOAD CNTL. connector	1	Used for external smart load control
6	M8*70 Expansion bolt	4	Lock the wall-mounted bracket to wall
7	Mounting bracket	1	Support the inverter
8	AC connector	2	Including sleeve, tubular terminals and connector
9	BAT+ connector	2	Quick-plug connector for battery cable
10	BAT- connector	2	
11	Smart meter (DTSU666.020)	1	Measure power generation
12	Current transformer (CT, CHINT NCTK-24 250A/50mA, 6-meter cable length)	3	Measure the grid current
13	Screw M5×12	3	1 for machine earthing end; 2 for fixing mounting bracket and inverter
14	Documentation	1	Quick guide
15	OT terminal (RNB14-5)	1	Used for grounding cable
16	Unlock tool for PV & BAT connector; Lock tool for AC connector nut	1	Uninstall the PV connector and BAT connector; Tighten tightening nut of AC connector

No.	Name	QTY	Description
17	Electric meter cable (10 meters, 26AWG)	1	Used for communication between meter and inverter

Table 3-1 Components and Mechanical Parts to be delivered

3.3 Environment Selection

- Follow the following principles to select an installation environment:
 - Protect the inverter against direct sunlight, rain and snow. It is recommended to install the inverter under a roof or shelter.
 - The installation position shall keep away from the reach of children, as well as the easily accessible locations.
 - The surrounding environment shall be dry, well ventilated and away from flammable and explosive areas.
 - The installation position shall keep away from water pipes and cables in the wall to avoid danger during drilling.
 - The installation space shall meet the requirements for device ventilation, heat dissipation and operation.
 - Do not install the device in desert areas.

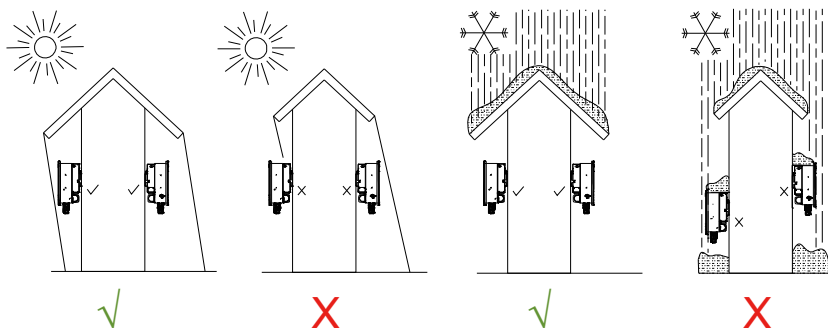

Figure 3-3 Installation environment

2. Installation method

Before installing the inverter, confirm whether the installed support structure can bear the weight of the inverter, and install the inverter as per the following

recommended methods:

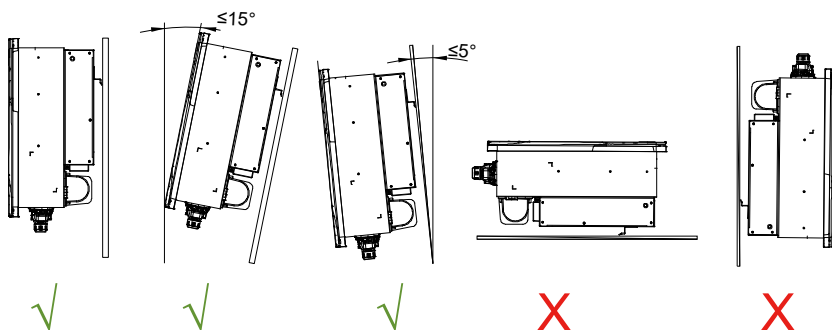

Figure 3-4 Installation Method

Installation Method	Description
Upright	If the installation position allows, install the inverter vertically;
Lean Back	If vertical installation cannot be guaranteed, the angle between inverter and the gravity direction shall be $\leq 15^\circ$;
Tilt forward	If vertical installation cannot be guaranteed, angle between inverter and the gravity direction shall be $\leq 5^\circ$;
No Horizontal	Inverters are not allowed to be installed horizontally;
No Upside down	Inverters are not allowed to be installed upside down;

Table 3-2 Description of Installation Method

3. Dimensions of installation space

To maintain good heat dissipation conditions for the inverter, the distance between the inverter and surrounding objects during installation and planning shall meet the following conditions:



NOTICE:

- In case an enclosed surrounding area, increase this distance appropriately.

- If multiple inverters are used, between them, there shall be no objects that affect the heat dissipation of the inverter.

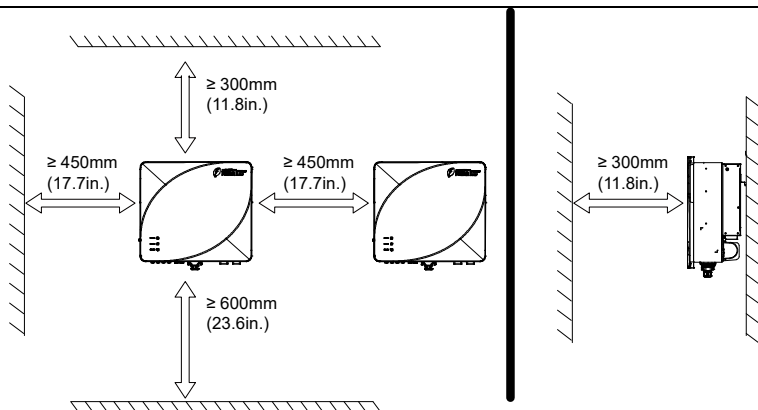
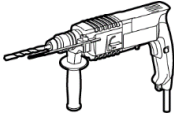
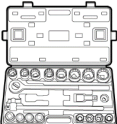

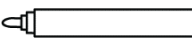

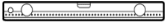

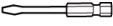





Figure 3-5 Dimensions of Installation Space

3.4 Installation Tools

The following installation tools are recommended for installation. If necessary, other auxiliary tools can be used onsite.

Type	Tools and Instruments		
Installation tool	 Percussion drill (bit $\Phi 10$ mm)	 Torque socket wrench	 Multimeter
	 Marker pen	 Steel tape	 Level gauge
	   Torque screwdriver	 Rubber hammer	 Diagonal pliers







Type	Tools and Instruments		
	 Crimping pliers (model: PV- CZM- 22100/19100)	 Wire stripper	 Hot air gun
	 Heat-shrinkable sleeve		
Personal protective equipment	 Safety gloves	 Protective glasses	 Safety shoes

Table 3-3 Installation tool and PPE

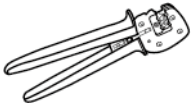
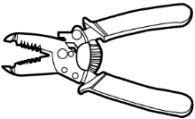
3.5 Inverter Installation

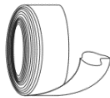

NOTICE:

It is recommended to use a PV switch lock to secure the PV switch, ensuring it remains in the "OFF" position during installation.

1. Place the mounting bracket horizontally on the wall and mark the punching position with a marker pen.

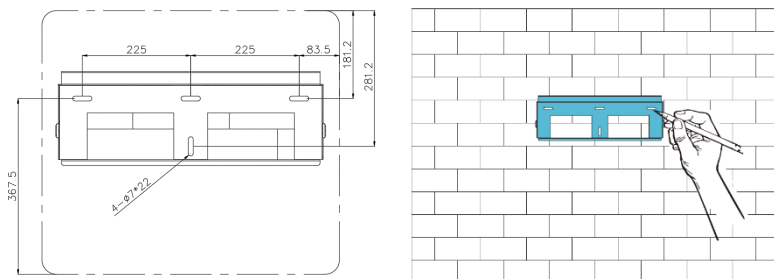

Figure 3-6 Mark Drilling Position

2. Use a percussion drill with a bit diameter of 10 mm (0.39 in) to drill holes of about 70 mm (2.75 in) depth. Use the rubber hammer to knock in the four expansion tubes.

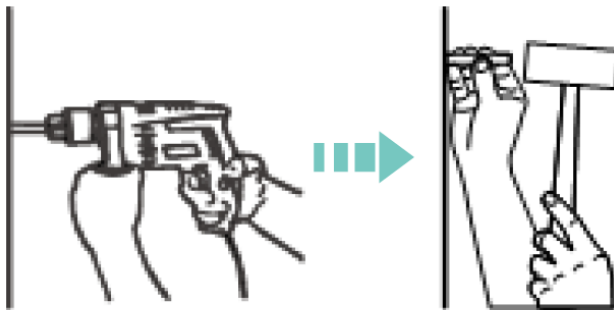

Figure 3-7 Drilling with Percussion Drill

3. Tighten four expansion screws into the expansion tubes to fix the inverter mounting bracket to the wall. Tool: PH2 screwdriver. Torque: 12.5 N.m.

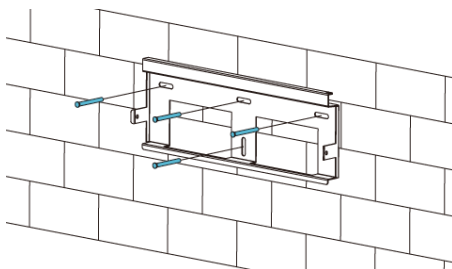

Figure 3-8 Fixing Mounting bracket on Wall

4. Hang the inverter onto the mounting bracket.

CAUTION:



The weight of inverter is about 41Kg.

If you want to manually hang the inverter, it is recommended to have at least two persons to hang the inverter.

Machine mounting: Tighten the lifting eyebolts (M10, prepared by customer), lift the inverter onto the mounting bracket.

Manual mounting: Lift the inverter safely by the four arrow positions.

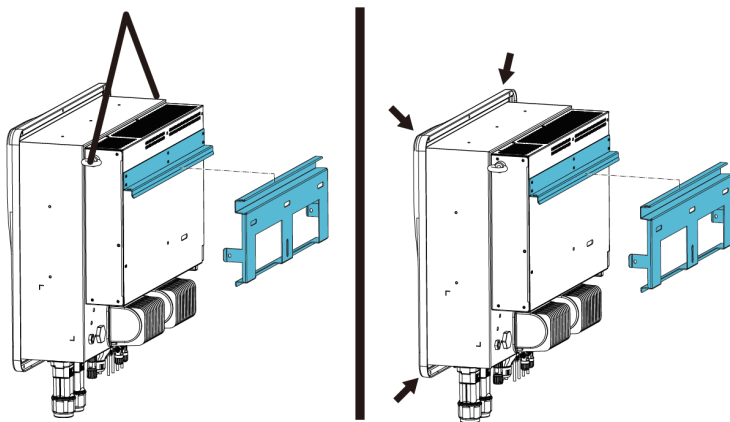

Figure 3-9 Hang onto Mounting bracket

5. Use PH2 screwdriver to tighten the two M5x12 screws (1) to fix the mounting bracket and inverter. Torque: 1.5-2 N.m.
Optional-It is recommended to install an anti-theft lock (2).

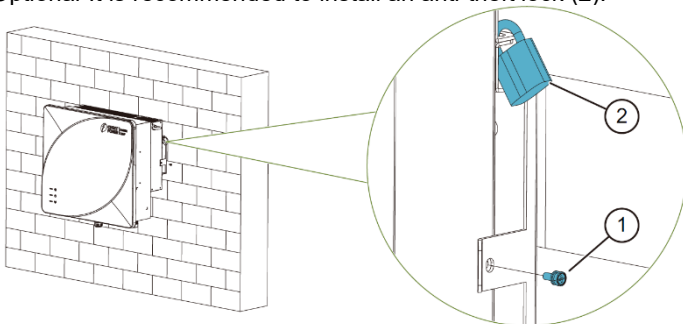

Figure 3-10 Fixing Mounting bracket and Inverter

4. Electrical Connection

4.1 Safety Instructions

**Danger:**

- Before electrical connection, ensure that the AC terminal, DC terminal and battery terminal of the inverter are de-energized. Otherwise, there is a risk of HV electric shock.
-

**Warning:**

- The technical parameters such as power grid level and frequency must meet the technical parameter requirements of the energy storage inverter.
 - The energy storage inverter can be connected to the power grid only after being approved by the local power supply company and installed by professional technicians.
 - All electrical connections must comply with local electrical installation standards.
-

**NOTICE:**

- The installation design of energy storage inverters must comply with the relevant standards or specifications of the country/region where the project is located.
 - Any energy storage inverter or system fault, resulting from failure to install it in accordance with the installation design requirements given in this manual, will not be covered by the warranty.
-

- Throughout the entire process of electrical connection, as well as all other operations carried out on energy storage inverters and other equipment, the following safety rules must be followed:
- Disconnect all external connections of the energy storage inverter and its internal power supply.
- Ensure that all disconnection points are not accidentally re-energized.
- Use a multimeter to ensure that the inverter port is completely de-

energized.

- Implement necessary earthing connections.
- Cover parts that may be live near the operating part with cloth made of insulating material.

4.2 Port and Cable Specifications

The following figure shows the inverter cable ports:

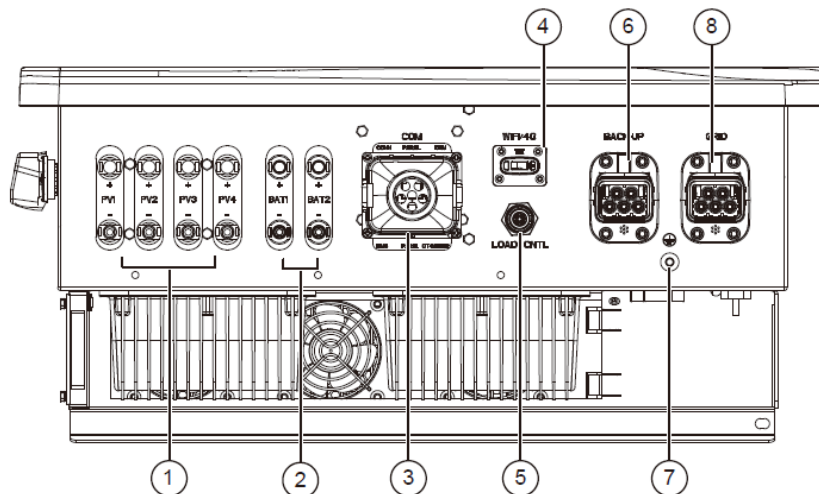

Figure 4-1 Cable Port of Inverter

S/N	Name	Description
1	PV DC input terminal	Connect PV connector
2	BAT terminal	Connect battery cable connector
3	COM port	Connect communication cable
4	WIFI/4G Communication port	Insert communication module
5	LOAD CNTL port	Connect smart load cable connector
6	BACK-UP port	Connect BACK-UP (Load) cable
7	External grounding hole	Connect external grounding cable
8	GRID port	Connect GRID cable

Table 4-1 Mapping between S/N and Port Name

4.3 Inverter Cable Specifications

Name	Cable Type	(Material of wire: copper)		
		Outer diameter	Conductor CSA (Cross-sectional area)	
		Range	Range	Recommend Value
AC-end, GRID and BACK-UP	Multi-core outdoor special cable	6.7~8.4mm	10-16 mm ² 6 AWG	16 mm ² 6 AWG
PV DC end	General PV cable in the industry (model PV1-F)	4.0~7.0mm	4-6 mm ² 12-10 AWG	4 mm ² 12 AWG
Protective grounding	Outdoor yellow-green special cable	6.4~7.3mm	6-10 mm ² 8-6 AWG	10 mm ² 8 AWG
Battery DC end	Outdoor special cable	6.4~7.3mm	10 mm ² 6 AWG	10 mm ² 6AWG

Table 4-2 Cable Specifications

4.4 Tools and Torques

S/N	Tools	Purpose	Torque Range
1	Phillips screwdriver	Fix external grounding terminal	2.0-2.2 N.m
		Tighten screws of AC connector	2.3-2.8 N.m
2	Phillips screwdriver	Tighten the crimping screws	0.3-0.5N.m
3	Tighten tool in accessory bag	tighten locking nut of LOAD CNTL Connector	2.6-2.9N.m
4	Diagonal pliers	Prepare cables	-
5	Wire stripper	Prepare cables	-
6	Crimping pliers	Prepare cables	-

Table 4-3 Tools and torque

4.5 Electrical System Wiring Diagram

NOTICE:

- According to the regulatory requirements in different regions, the wiring methods of N line and PE line at ON-GRID and BACK-UP ports of inverters are different. The specific requirements of local laws and regulations shall prevail.
- Inverter ON-GRID and BACK-UP AC ports with built-in relays:
 - When the inverter is in off grid mode, the built-in ON-GRID relay is in the disconnected state;
 - When the inverter is in grid connected mode, the built-in ON-GRID relay is in the closed state.
- Circuit breakers shall be connected on the AC side and battery side:
 - Specification requirements for circuit breaker at battery side: rated current $\geq 63A$, rated voltage $\geq 600V$.
 - Specification requirements for circuit breaker at AC side: rated current $\geq 75A$, rated voltage $\geq 230V$.



-
1. The wire connection in Australia, New Zealand and South Africa is shown in the following figure (If N and PE are not short circuited, the voltage between N and PE is required to be less than 10V)

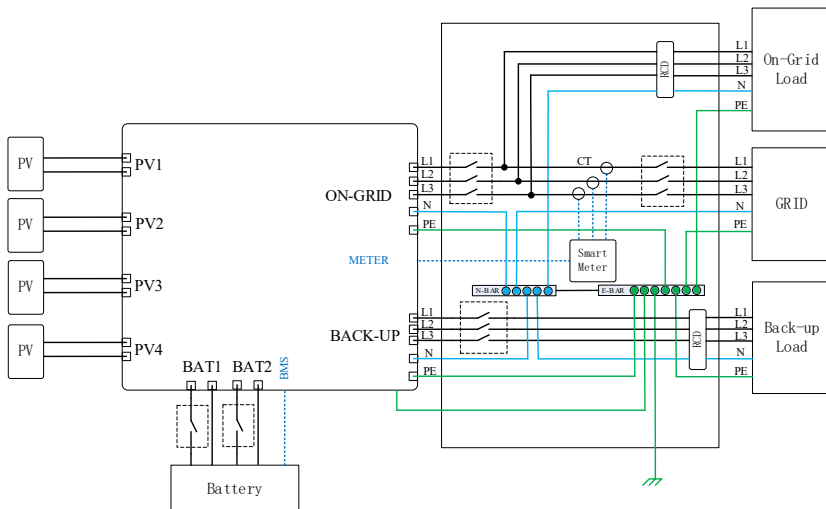

Figure 4-2 Wire connection in Australia, New Zealand and South Africa

- For other regions except Australia, New Zealand and South Africa, the wiring method is as shown in the following figure:

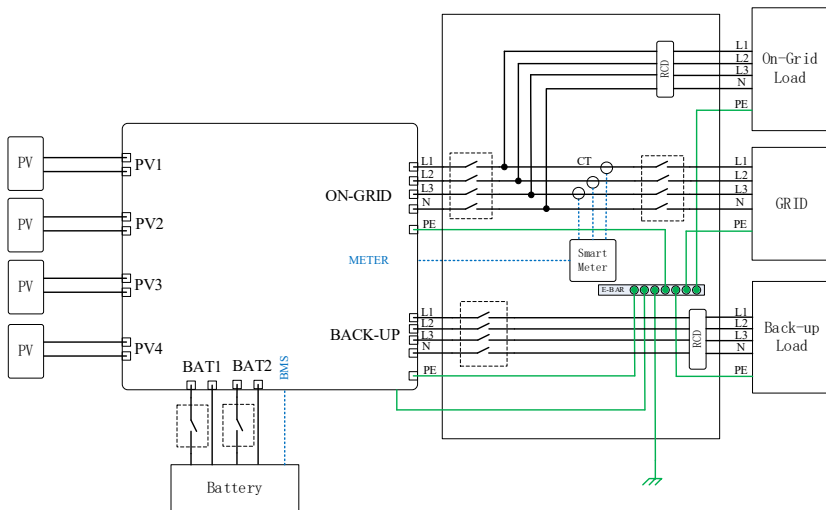

Figure 4-3 Wiring Modes in Other Regions

4.6 Protective Grounding Cable Connection

WARNING:



- The protective earthing of the housing cannot replace the protective earth cable of the AC output port. When wiring, ensure that both protective earth cables can be reliably connected.
- When there are multiple inverters, ensure the protective earthing equipotential connection of all inverter housings.
- To improve the corrosion resistance of terminals, it is recommended to apply silicone or paint on the outside of the earthing terminal for protection after the installation of the protective earth wire connection.

Please follow the steps below for wiring:

1. Remove an appropriate length of insulation layer from the grounding cable (customer needs to prepare the grounding cable, color requirement: Yellow-green)

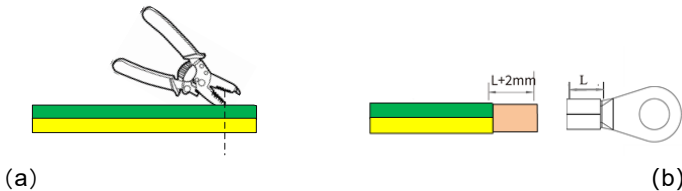

Figure 4-4 Remove insulation layer

2. Insert the exposed wire core into the crimp area of the OT terminal, use crimping pliers to crimp the OT terminal. Use hot air gun and heat shrink tube to seal the crimp area.



Figure 4-5 Crimp and seal the OT terminal

3. Align the earth cable with the earthing port of the inverter and tighten the

M5x12 screw. Tool: cross screwdriver. (Note: After wiring, external grounding position needs to be coated with glue or paint).

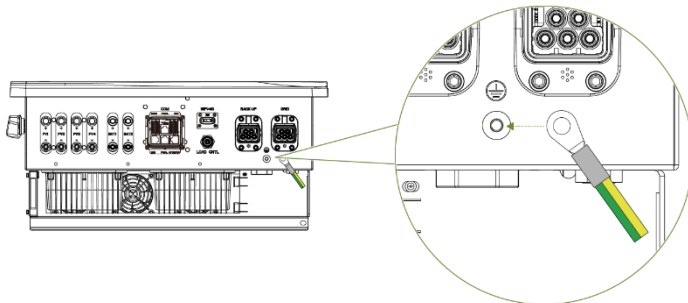

Figure 4-6 Schematic Diagram of Wiring

4.7 GRID and BACK-UP (Load) Cable Connection



WARNING:

- After the inverter is powered on, the BACK-UP port is energized. If maintenance is required on the BACK-UP load, power off the inverter, disconnect all DC (including PV and battery) and AC power. Otherwise, it may cause electric shock.
- Pay attention to distinguishing between load wiring ports and power grid wiring ports.
- Pay attention to disconnecting the switch on the grid side first, and then carry out wiring after the inverter is powered off.

Please follow the steps below for wiring:

1. Remove jacket and insulation layer from the multi-core outdoor special cable.

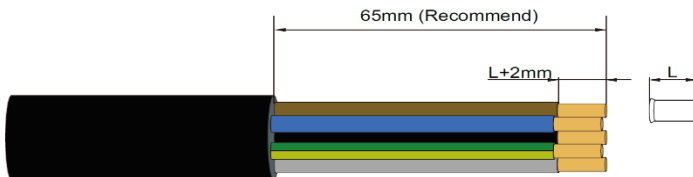

Figure 4-7 Remove jacket and insulation layer

2. Insert the exposed wire cores into tubular terminals and use crimping plier to crimp them.

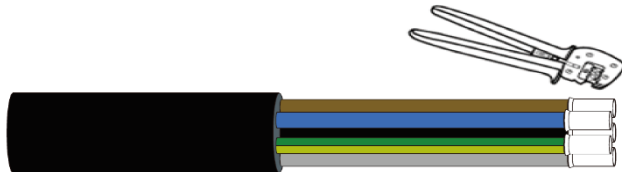

Figure 4-8 Remove jacket and insulation layer

3. Loosen the locking nut (1), thread the cable through the locking nut and sleeve (2), insert the tubular terminals of cables (3) into the connector (4) and tighten the screws.

NOTICE:

Connect the wires to corresponding ports (L1, L2, L3, PE and N). Otherwise, the inverter will be damaged.

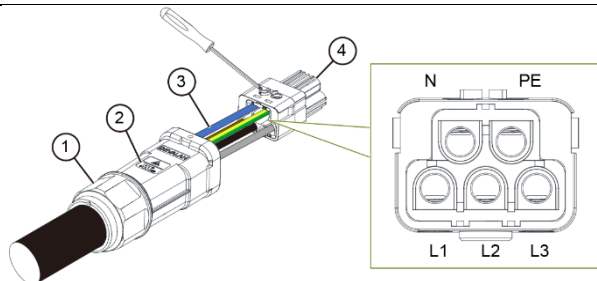

Figure 4-9 Lock cable assemble the connector

4. Insert the connector (1) into the sleeve (2) until you hear a “click” sound, then tighten the locking nut (3) manually.

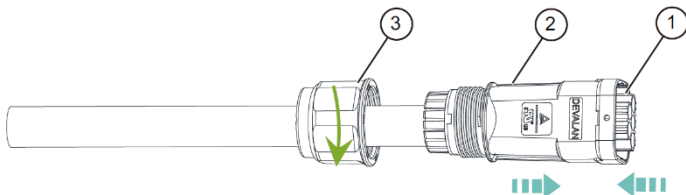

Figure 4-10 Assemble the connector

5. Insert the AC connectors to corresponding port (GRID and BACK-UP) until you hear a “click” sound.

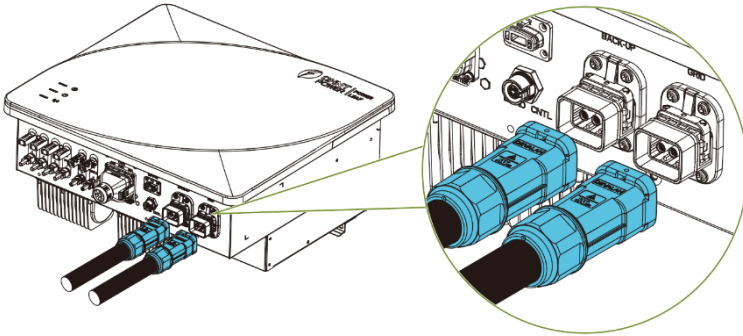

Figure 4-11 Insert the AC connector

4.8 Battery Cable Connection



DANGER:

- Batteries used together with the inverter shall be approved by the inverter manufacturer, and the approved battery list can be obtained from the official website.
- Do not connect the same battery pack to multiple inverters, as this may cause damage to the inverters.
- One DC switch is required between the inverter and the battery.

Connect the battery cables as the following steps:

1. Remove an appropriate length of insulation layer from battery cable.
Insert the exposed areas of positive and negative battery cables into the metal terminals respectively and crimp them with hydraulic crimping plier and 10 mm² hexagonal mold coupling.

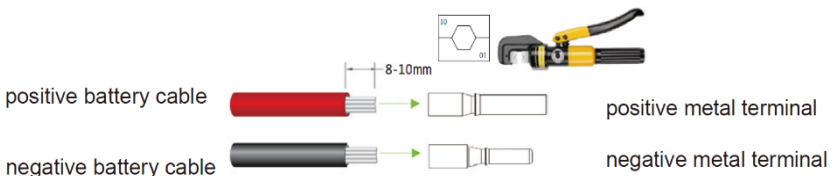

Figure 4-12 Treatment of Insulation Layer

2. Insert the crimped terminals into the BAT connectors until you hear a click sound, and tighten the locking nuts.

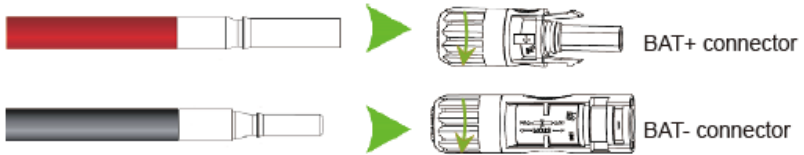

Figure 4-13 Inserting Cable Terminal into Connector Housing

3. Connect the BAT connectors to corresponding BAT ports until you hear a click sound.

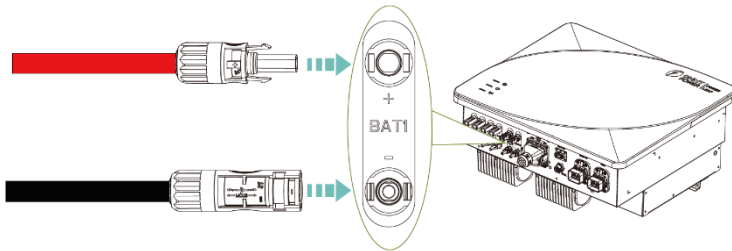

Figure 4-14 Inserting battery cable into Inverter Port

4.9 PV Cable Connection

Danger:



- Do not connect the same PV string to multiple inverters, as this may cause damage to the inverters.
- Ensure that the positive pole of PV string is connected to PV+ and the negative pole to PV- of inverter.

Check the polarity before terminating the DC cables of PV strings according to the following steps, as shown in Figure 4-15:

- i. Use a multi-meter to measure the PV strings' cable ends and check the polarity.
- ii. The positive (+) terminal of cable should match the positive (+) terminal of inverter's DC input.
- iii. The negative (-) terminal of cable should match the negative (-) terminal of inverter's DC input.

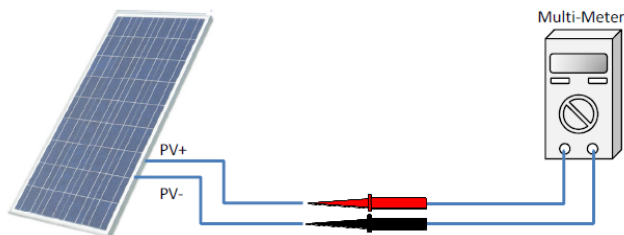

Figure 4-15 Checking the Polarity of PV Panel Cable

1. Properly treat the insulation layer of the PV string cable.

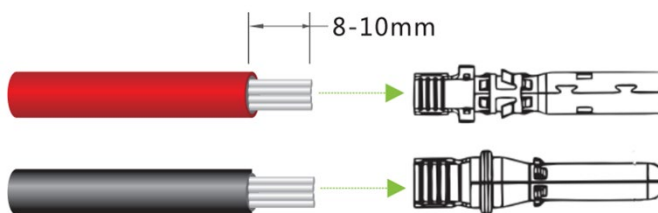

Figure 4-16 Treatment of Insulation Layer

2. Crimp the metal terminals of the DC input connectors (delivered with the device) with specialized crimping pliers.

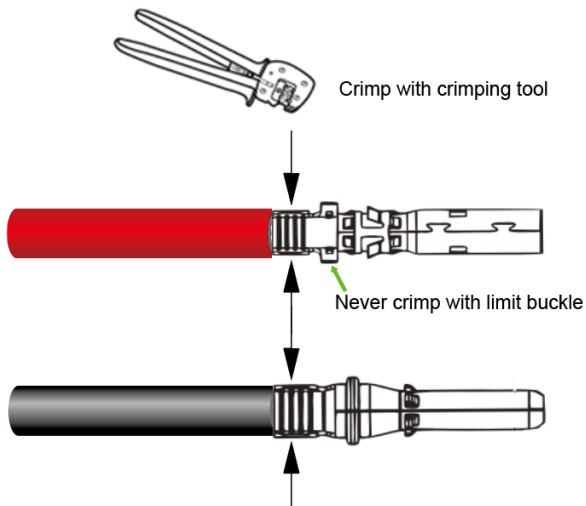

Figure 4-17 Terminal Crimping

3. Insert the crimped DC cables into the DC input connector housing until you hear a “click” sound, and tighten the sealing nuts.

NOTICE:

The DC input connectors must be those delivered with the device or have the same model from the same manufacturer. Otherwise, poor contact may occur and affect normal use.

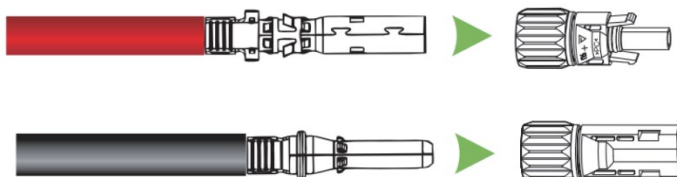

Figure 4-18 Inserting Cable Terminal into Connector Housing

4. Measure the voltage of each string with a multimeter. Ensure that the polarities of the DC input power cables are correct.

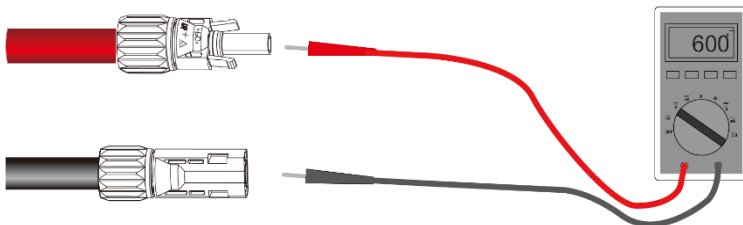

Figure 4-19 Measure string voltage and polarities

5. Connect the assembled DC positive and negative cables with DC connectors to the positive and negative poles on the inverter side, respectively.

NOTICE:

Before connecting to device, it must be confirmed that the earth cable shall be connected properly and PV switch shall be in OFF state.

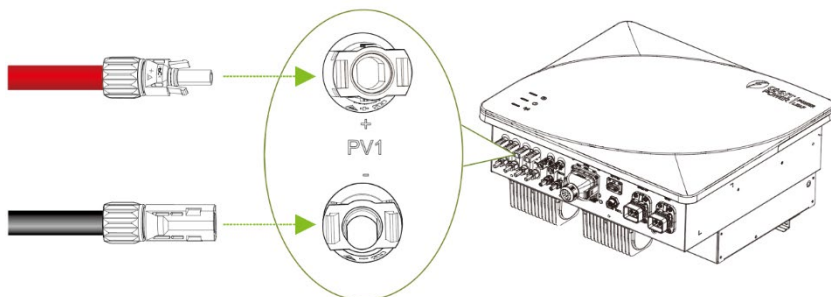

Figure 4-20 Inserting PV Cable into Inverter Port

4.10 Communication Cable Connection

4.10.1 Definitions of signal pins

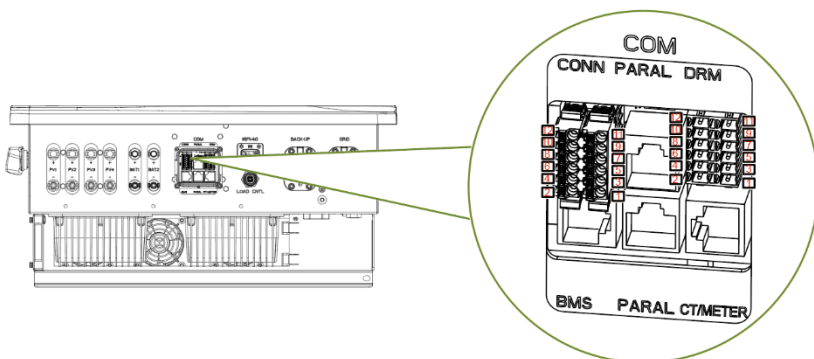
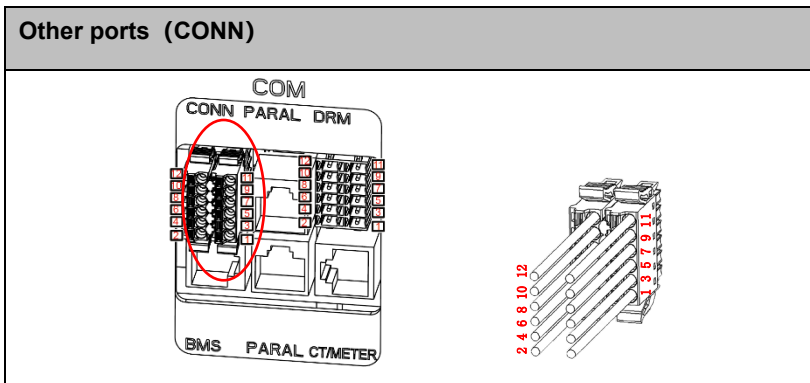
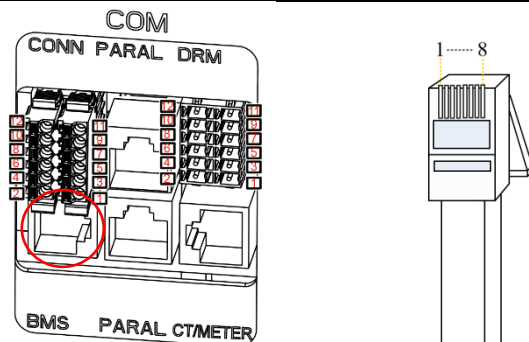

Figure 4-21 External Communication Port



Pin	Signal	Description
1	EMS_RS485A	485A communication for battery EMS, optional
2	/	/
3	EMS_RS485B	485B communication for battery EMS, optional
4	/	/
5	DI2+	DI2+ dry contact signal, optional
6	Meter_RS485A	485A communication for smart meter, optional
7	DI2-	DI2- dry contact signal, optional
8	Meter_RS485B	485B communication of smart meter, optional
9	DI+	DI+ dry contact signal, optional
10	EV Charger_RS485B	485B communication for EV charger, optional
11	DI-	DI- dry contact signal, optional
12	EV Charger_RS485A	485A communication for EV charger, optional

Battery Communication Port (BMS)



RJ45 connector supporting connection standard

Pin	Signal	Description
1	BAT_RS485A	Battery 485A communication
2	BAT_RS485B	Battery 485B communication
3	BAT_Temp+	Temperature signal of lead-acid battery
4	BAT_CANH	Battery CANH communication
5	BAT_CANL	Battery CANL communication
6	BAT_Temp-	Temperature signal of lead-acid battery
7	BAT_RS485B	Battery 485B communication
8	BAT_RS485A	Battery 485A communication

Parallel Function Port (PARAL)

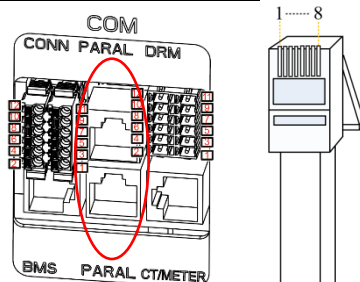

RJ45 connector supporting connection standard

Pin	Signal	Description
1	LowRateSyncFdb	Low rate synchronization signal
2	ISOGND	Grounding
3	ISOGND	Grounding
4	PARALLEL_CANH	Parallel CANH communication
5	PARALLEL_CANL	Parallel CANL communication
6	HRateSyncFdb	High rate synchronization signal
7	Meter_RS485A	RS485A meter communication
8	Meter_RS485B	RS485B meter communication

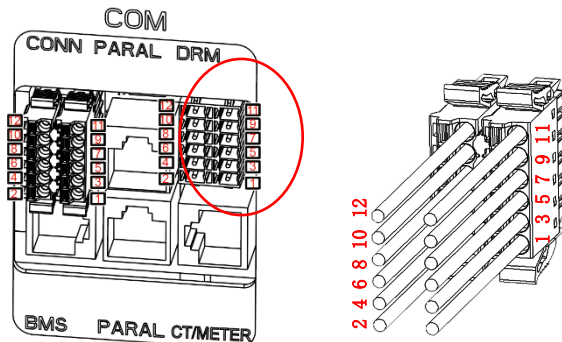
Australian Grid Dispatching and RSD Port (DRM&RSD)

RJ45 connector supporting connection standard

Pin	Signal	Description
1	COM/DRM0	DRM dispatch signal, optional
2	REF/GEN	DRM dispatch signal, optional
3	DRM4/8	DRM dispatch signal, optional
4	DRM3/7	DRM dispatch signal, optional
5	DRM2/6	DRM dispatch signal, optional
6	DRM1/5	DRM dispatch signal, optional
7	ISOGND	12V power supply to earth, optional
8	+12VCOMM	12V power supply for external circuit, optional
9	ISOGND	12V power supply to earth, optional
10	RSD_POWER	Power supply for RSD, optional
11	RSD+	RSD positive end, optional
12	RSD-	RSD negative end, optional

External CT and Smart Meter Communication Port (CT)		
		
Pin	Signal	Description
1	ExtCT2+	External CT2 positive terminal
2	ExtCT2-	External CT2 negative terminal
3	ExtCT1+	External CT1 positive terminal
4	ExtCT3+	External CT3 positive terminal
5	ExtCT3-	External CT3 negative terminal
6	ExtCT1-	External CT1 negative terminal
7	Meter_ RS485B	RS485B meter communication
8	Meter_ RS485A	RS485A meter communication

Table 4-4 Description of External Communication Port

4.10.2 External Communication Cable Connection

Please follow the steps below for wiring:

1. Press the buckles of the COM cover and take off the cover.

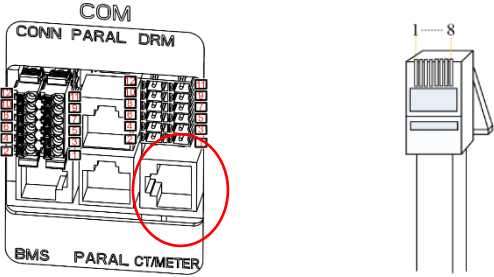
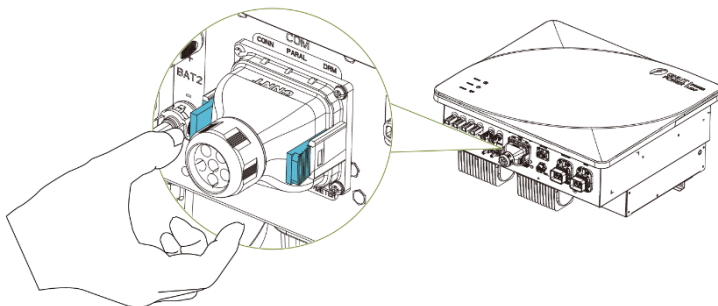

Figure 4-22 Remove the protective cover

2. Thread the communication wires through the nut (3), seal ring (2) and waterproof cover (1) in turn. If necessary, remove jacket and insulation layer from proper communication cable and crimp cord end terminals onto exposed wire core at first.

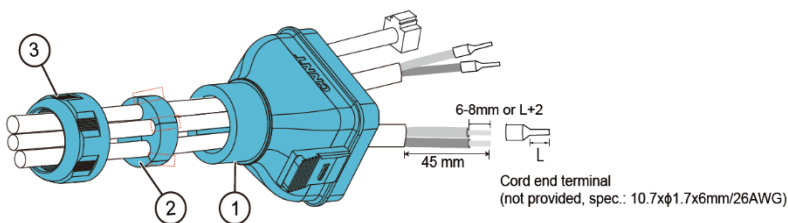

Figure 4-23 Thread the wires

3. (a) Insert RJ45 connectors into corresponding ports till you hear a "click" sound. (b) Press orange buckles, insert cord end terminals into terminal holes and release buckles to crimp terminals.

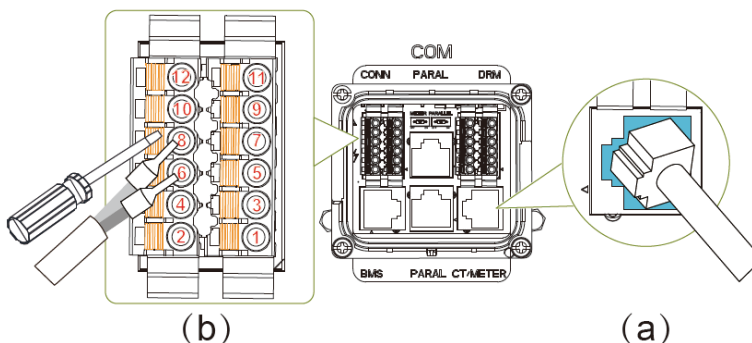

Figure 4-24 Insert RJ45 connectors & insert cord end terminals

4. Adjust cable length and recover the protective cover, and tighten the locking nut manually.

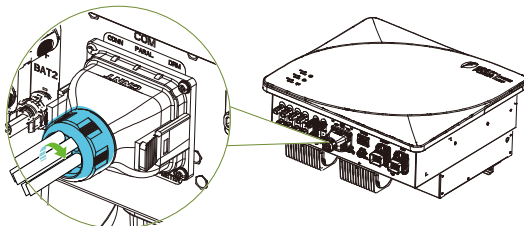

Figure 4-25 Protective Cover Locking

4.11 COM Module Installation

Insert the COM module into the WIFI/4G port of the inverter. When you hear a "click" sound, it indicates that the COM module is firmly inserted.

Note: the indicators of COM module face towards front cover.

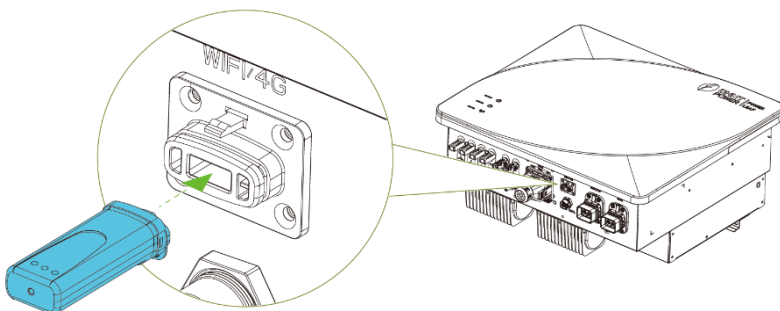

Figure 4-26 Insert the COM module

4.12 Parallel connection function

AC output sides of inverters can be connected in parallel to extend power, meeting users' requirement of on-grid and off-grid switching.

DANGER!



All inverters in parallel PCS system must be considered as a unified system. This means that the parameters for each inverter must be set identically. The inverter can only be powered on when the parallel enable function is activated. Failure to do so may result in damage to

the inverter.

NOTICE!

- Each inverter must be configured with a single battery system, sharing batteries will cause system working abnormally.
- Support up to 10 inverters in parallel and AC cable length of each inverter shall be the same.
- The power of every inverter shall be consistent, and batteries connected to all inverters must be consistent and all the same.
- Before powering on, please read section 5 and APP section carefully.
- Any single inverter in parallel system detects abnormal grid status, all inverters will report grid faults. i.e.: grid faults will be synchronized; other faulty inverters will issue warning or trigger protection individually.
- If assistance is needed, please contact the after-sales service personnel.



Set the parallel function by following the steps below:

1. Follow the diagram provided for parallel connection. Before wiring, ensure that all the devices and ports are electrically neutral.

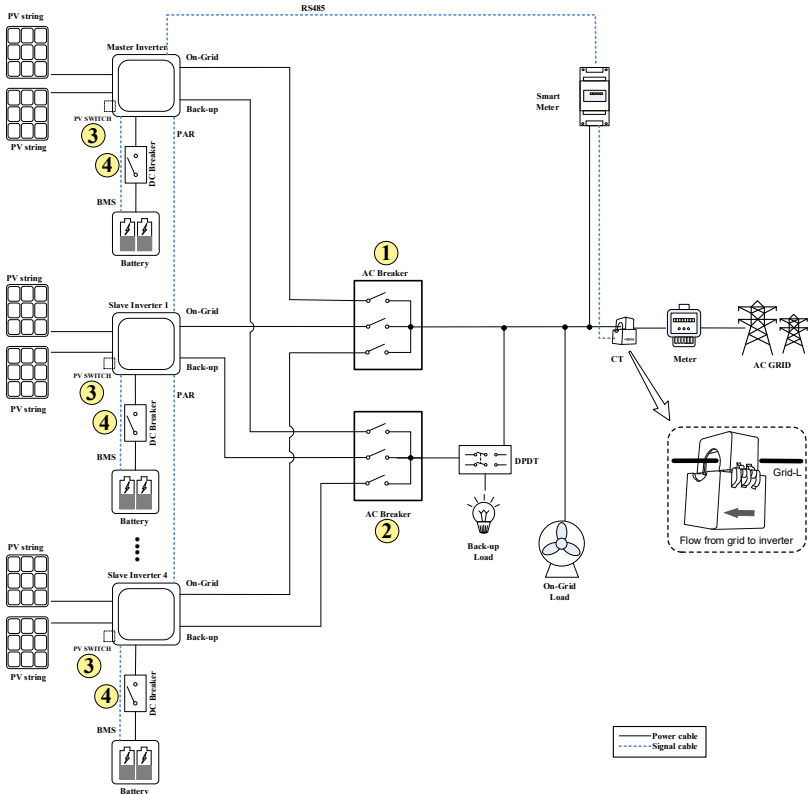

Figure 4-27 Parallel connection

2. Parallel communication: Use standard RJ45 net cable to connect the PARAL port of every inverter, turn the PARALLEL DIP switch (S1) of the first and the last inverter to “ON” position, and turn Parallel DIP switch of other inverters to “OFF” position. Turn the METER DIP switch (S2) of the last inverter to “ON” position, and turn METER DIP switch (S2) of other inverters to “OFF” position as below. Note: No.1 is Master inverter.

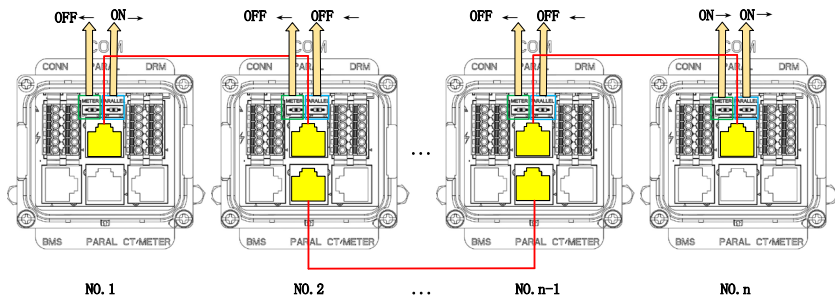

Figure 4-28 Parallel Net Cable Connection

3. Power on the parallel system as the following steps in Figure 4-28.
 - ① Close grid side AC circuit breaker of each inverter.
 - ② Close load side AC circuit breaker of each inverter.
 - ③ Close PV side PV switch of each inverter.
 - ④ Close energy storage side DC breaker of each inverter.
4. Ensure that the regulatory settings of each inverter are consistent. Configure the regulatory settings through MatriCloud App in the following way:
 - MatriCloud App: Settings -> System configuration Para -> Selection of regulationsd, select the corresponding regulation according to local electrical standards.
5. Parallel ID setting: When working in parallel, set a unique ID for each inverter. It is important to designate only one "master" within the entire parallel system, while all others should be configured as "slaves". Furthermore, each "slave" inverter must have a distinct ID; duplicate IDs among the "slave" inverters are not permissible. Please set in the following way:
 - MatriCloud App: Settings -> Others Para -> Parallel ID -> set the inverter to be "master" or "slave"
6. Enable the parallel function. By default, the parallel function is disabled. To enable parallel operation, ensure that each inverter's parallel function is activated. Please set in the following way:

- MatriCloud App: Settings -> Others Para > Parallel Setting->enabled
7. Please check the system wiring and software settings again.
 8. Power on. After finishing all the settings, you only need to power on one inverter and the other inverters can power on automatically.
(Note: Powering off is the same as powering on, you only need to power off one of the inverters, and the other inverters will execute synchronously.). you can power on the inverter in the following way:
 - MatriCloud: Settings -> Ctrl Commands -> Power-on/off command -> power on.
 - You can also click the on/off button in the top right corner of the home page to power on and power off the device.

4.13 LOAD CNTL Cable Connection

User can choose whether to enable the smart load control function and perform correct wiring operations according to the schematic diagram.

NOTICE!



- NO dry contact current is not more than 3A.
- AC contactor drive current is not more than 5A.
- It is prohibited to directly connect the load to the NO port.
- It is recommended to install AC contactors in the corresponding rails of the distribution cabinet.
- Before powering on, please carefully read section 5 and APP section.

Please refer to the following steps to set up the smart load function:

- (1) The AC contactor can be regarded as a switch: the inverter controls the opening or closing of the AC contactor, thereby controlling the connection or disconnection of the load.

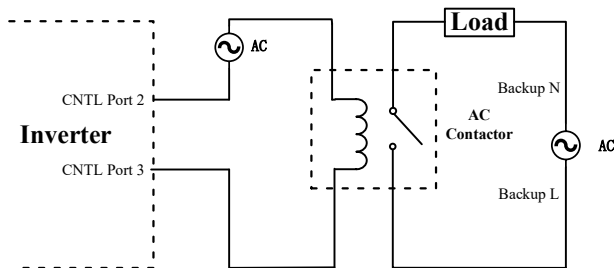

Figure 4-29 Schematic Diagram of smart load

- (2) When wiring, please ensure that all devices and ports are not live.
- (3) The LOAD CNTL terminal is externally connected with three control cables, labeled as ①, ②, and ③; Connect COMM (Common load) wire to port ②, and connect NO (normally open) wire to port ③.

Note: Connect wires to corresponding ports, otherwise the inverter may be damaged.

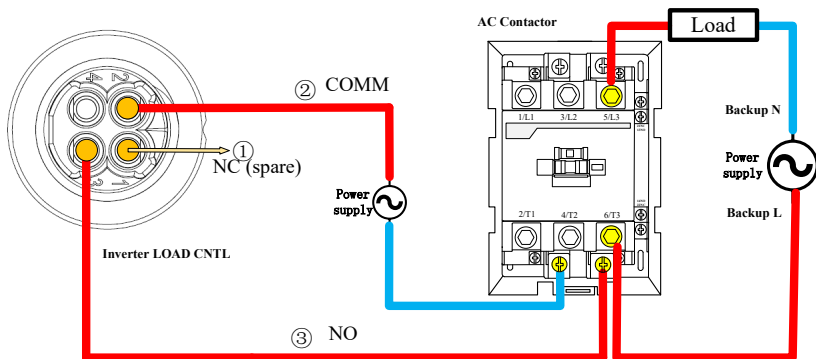

Figure 4-30 Schematic Diagram of smart load connection

Load control cable shall be copper cable, detailed specification is as below:

Cable Type	Outer diameter	Conductor CSA (Cross-sectional area)	
	Range	Range	Recommended value
outdoor special 2-core cables	2.2~2.8mm	0.3-0.5 mm ²	0.5 mm ²
		22-20 AWG	20AWG

Steps of LOAD CNTL connection:

1. Loosen the locking nut (1), sleeve (2) and connector (3). Thread load control cable wire through locking nut and sleeve. Strip off wires by referring to AC cable stripping.

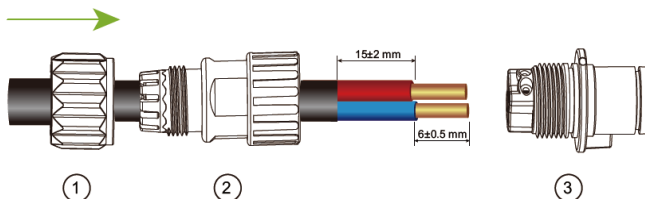

Figure 4-31 Thread the wires through the connector

2. Connect COMM (common load) wire to port 2; connect NO (normally open) wire to port 3. Tighten the crimping screws with a screwdriver. Note: Connect the wires to corresponding ports. Otherwise, the inverter will be damaged.

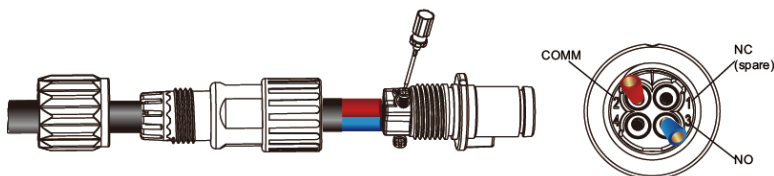

Figure 4-32 Connect wires

3. Tighten connector (1). Then adjust cable length, tighten locking nut (2) with a torque value of 2.6-2.9N.m.

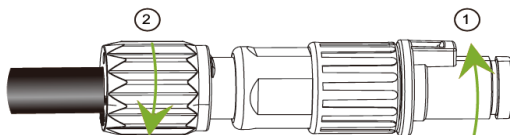

Figure 4-33 Tighten connector



WARNING:

Tighten the locking nut with tightening tool to prevent accidental removal by hand, which may cause electric shock.

4. Align positioning bar on LOAD CNTL connector with slot on the LOAD CNTL interface, and insert the connector until you hear a "click" sound.

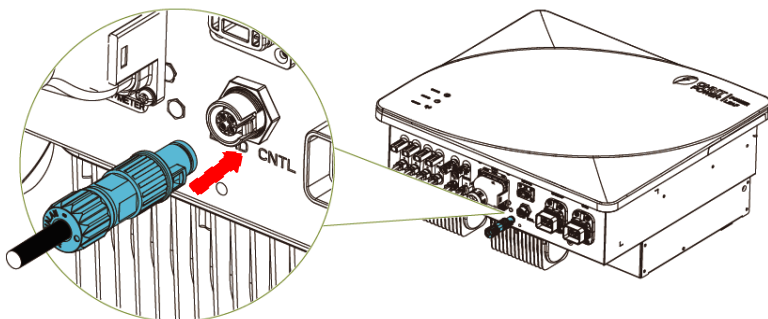

Figure 4-34 insert the connector

4.14 DRM Connection

The COM port of inverter provides an interface to meet power grid dispatching demands. DRM and Ripple Control can only meet one kind of dispatching requirement simultaneously.

4.14.1 DRM

IMPORTANT:



According to Australian AS4777.2-2015 standard requirements, this series of inverters supports Demand Response Modes (DRM).

The DRM interface inside COM port responds to the corresponding demand mode by detecting short-circuited switch. The wiring diagram between the DRM interface and DRED is shown in the following figure:

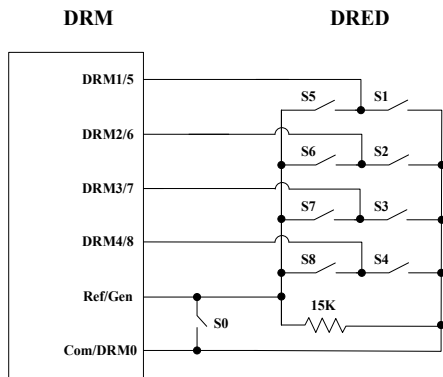

Figure 4-35 DRED Wiring

DRM mode is as the following table.

Mode	Asserted by Shorting Terminals on Inverter	Switch Operation on External DRED
DRM 0	Ref/Gen & Com/DRM0	Close S0
DRM 1	DRM1/5 & Com/DRM0	Close S1
DRM 2	DRM2/6 & Com/DRM0	Close S2
DRM 3	DRM3/7 & Com/DRM0	Close S3
DRM 4	DRM4/8 & Com/DRM0	Close S4
DRM 5	DRM1/5 & Ref/Gen	Close S5
DRM 6	DRM2/6 & Ref/Gen	Close S6
DRM 7	DRM3/7 & Ref/Gen	Close S7
DRM 8	DRM4/8 & Ref/Gen	Close S8

Table 4-5 Method of asserting DRMs

4.14.2 Ripple Control



IMPORTANT!

According to VDE-AR-N4105:2018-11 code, management equipment of European grids, represented by Germany, uses Radio Ripple Control Receiver (RRCR) to convert power grid dispatching signals and send them as dry contact signals.

The wiring diagram of the inverter DRM signal and RRCR signal is shown in the following figure:

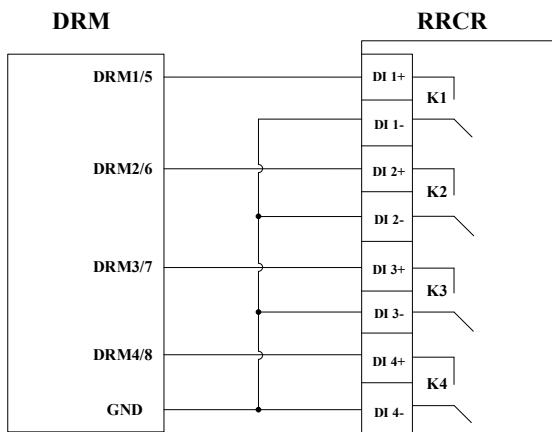

Figure 4-36 DRM signal and RRCR signal wiring

The following table shows the allocation of inverter power levels:

Asserted by Shorting Terminals on Inverter	Switch Operation on RRCR	Active power *P _n	Cos(φ)
DRM1/5 & GND	Close K1	0%	1
DRM2/6 & GND	Close K2	30%	1
DRM3/7 & GND	Close K3	60%	1
DRM4/8 & GND	Close K4	100%	1

Table 4-6 RRCR power distribution

4.15 External Rapid Shutdown Device (RSD)

NOTICE!



- Connect external switch between RSD POWER and RSD+, which shall be normally closed when inverter works normally.
- The external switch shall disconnect and not bounce back after pressed.
- Connect RSD box between RSD+ and RSD-.
- Before powering on, please read section 5 and APP section carefully.

The inverter supports external RSD. Please refer to the following steps to enable RSD function:

1. When wiring, please ensure that all devices and ports are not live.
2. Connect PIN 10 and PIN 11 of DRM terminal to both ends of the external switch, connect PIN 12 to GND terminal of the RSD box power input. Connect one end (connected to PIN 11) of the external switch to +12V terminal of the RSD box power input.

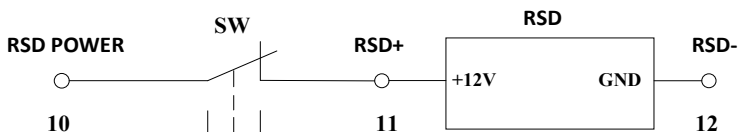

Figure 4-37 RSD schematic diagram

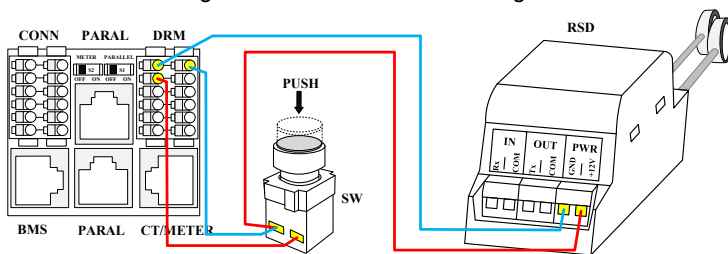

Figure 4-38 RSD wiring schematic diagram

3. The external quick shutdown function is disabled by default. After powering on the inverter, enable it through the settings interface of MatriCloud.

RSD enable: Settings -> Safety Protection Parameters -> RSD function setting -> RSDEnable.

4.16 AFCI (Arc-Fault Circuit-Interrupter) protect function

The type of ARC protect device is F-I-AFPE-1-2-2. The explanation of the device type is as the following table.

Letter	Meaning
F	Full coverage
I	Integrated
AFPE	Provide the function of detecting and interrupting
1	One string input port connect to one PV string
2	Each detection channel has two string input ports
2	2 detection channels

Table 4-5 Meanings of F-I-AFPE-1-2-2

ARC detection:

This function is applied to manually detect if there is fault in the ARC board. When the inverter is running normally, if use this function, the inverter will begin ARC detection.

- If there is any fault, the ARC detection will show “failure”, and record “AFCI Self-test Fault” in “Fault history”.
- If there is no fault, the ARC detection will display “success”.

Note: the inverter will automatically run ARC detection before normal running every day. Generally, it is not necessary to use ARC detection when the inverter is running normally.

ARC elimination:

This function is applied to manually eliminate the “AFCI Fault” fault.

When the fault occurs, there are two methods to reconnect the inverter: Automatic re-connection and manual re-connection.

- Inverter has the function of 4 times automatic re-connection in 24 hours: when the ARC fault occurs, inverter record “AFCI Fault” in “Fault history”, and the inverter will reconnect after 5 minutes;
- When the fault occurs the fourth time, it is necessary to manually eliminate the ARC fault. After the fault elimination, the inverter continues to maintain the default 4 times automatic re-connection function in 24 hours.

4.17 AC Coupling Function

The AC coupling system is designed to use green energy to quickly charge the battery in case power grid is unavailable to charge the battery (some countries prohibit grid charging the battery).

An existing PV system can be retrofitted to be a PV ESS with the addition of the hybrid inverter. The power generation from the existing PV inverter will be firstly provided to the loads and then charge the battery. With the energy management function of the hybrid inverter, the self-consumption of the new system will be greatly improved.

The use of AC coupling system requires two electric meters, one electric meter is provided in packaging box, while the other one needs to be purchased by the user.

The current direction of the AC coupling side meter is the same as that of grid side meter (with arrow pointing to inverter, can also be changed in App).

The communication line of AC coupling side meter shall be connected in parallel with that of grid side meter, and then connected to the system.

Considering that actual communication line may be very long (30m or more), one 120 Ohm matching resistor can be added on both ends of communication line if needed.

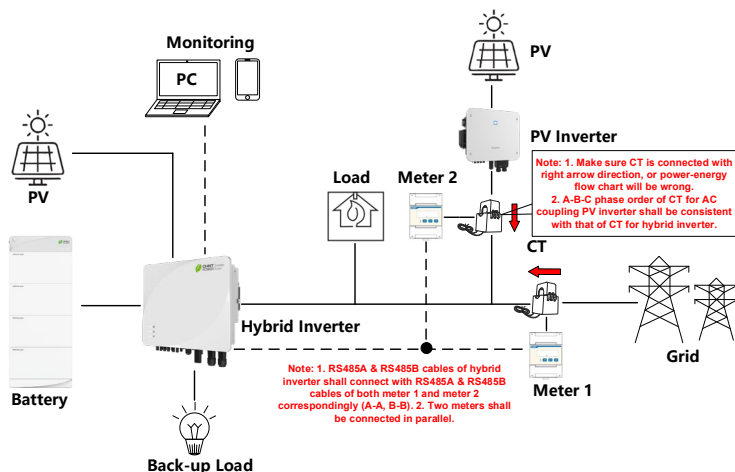

Figure 4-39 AC coupling wiring schematic diagram

Note: PV inverters in the AC coupling system are not allowed to enable the zero export (anti-reflux) function.

For the detailed steps of AC coupling, please refer to section 7.2.2 AC Coupling or section 8.3.1.1 AC Couple.

4.18 Generator Function

This residential energy storage system supports the integration of a diesel generator (hereinafter referred to as “generator”) to significantly enhance power supply reliability.

When the grid experiences a prolonged outage or the battery state of charge becomes low, the system can start the generator automatically or manually to ensure continuous power supply to critical loads.

NOTICE!

- The generator must be equipped with one AC relay (normally closed) and one ATS (Automatic Transfer Switch, user-supplied). The ATS is used to switch between the grid and generator, ensuring that the generator and the grid are not connected at the same time
 - (1) Recommended operating voltage range for the AC relay AC: 150V~287V (phase voltage)
 - (2) The ATS switching time must be greater than 30 seconds.
- The rated power of the generator should be greater than the total power of the connected loads and the battery charging power.
- When using the generator function, the user must additionally select and install a smart meter to collect generator operating data. The specification of this meter is identical to that of the AC coupling meter. (The **AC Coupling** and **Generator** functions are **mutually exclusive** and cannot be used simultaneously.)



The Figure 4-40 below shows the wiring diagram of the inverter equipped with a generator. The generator and the grid are connected to the inverter's grid-side port through an ATS.

Both the generator and the grid require a meter. The CT installation direction should point from the grid side and the generator side toward the inverter.

The RS485 communication signals of the two meters are connected in parallel:

- Generator Meter RS485A → Grid Meter RS485A
- Generator Meter RS485B → Grid Meter RS485B

Then connect the parallel RS485 signals to the inverter's RS485 port.

The inverter's dry contact output signal is connected to the generator signal port through an AC relay.

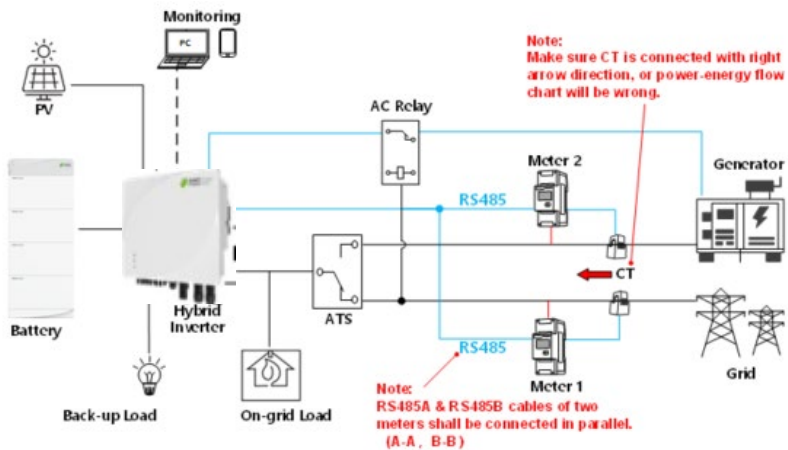

Figure 4-40 Generator System Wiring Schematic Diagram

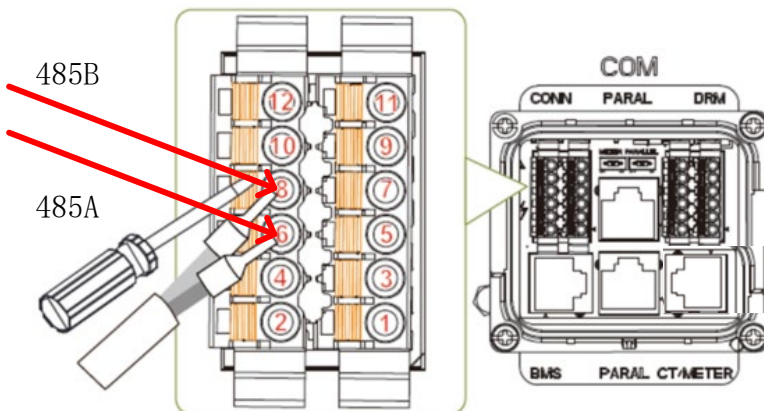

Figure 4-41 485 Communication Wiring Diagram

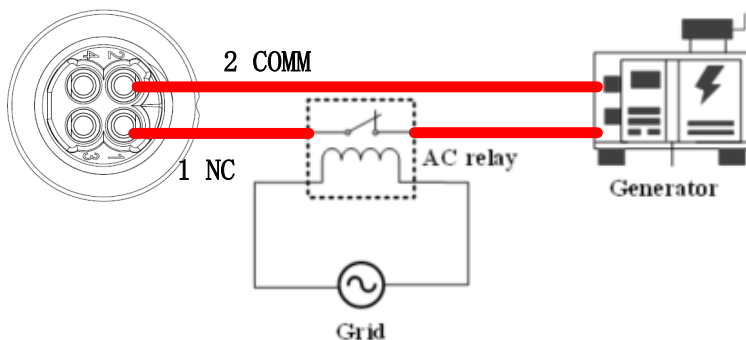

Figure 4-42 Dry Contact Connection Signal Diagram

Configure addresses of both energy meters according to the following steps and diagram. NOTE: Each meter must have a unique address. Ensure that the meter is connected to the grid and powered on before modifying any parameters.

1. Press the "SET" button on meter panel.
2. Input password "701" to access setting function.
3. Select target parameter and navigate to relevant setting.
4. Check the Generator meter address: If it matches the default value 2, you can exit directly. If not, you can:

- Modify the inverter's address to match the meter's address. Or change the meter address to the default value 2 via the meter panel.
- Check the Baud Rate: the default baud rate is 9600. Ensure that the baud rate of both the grid-side meter and the AC-coupled meter are the same.

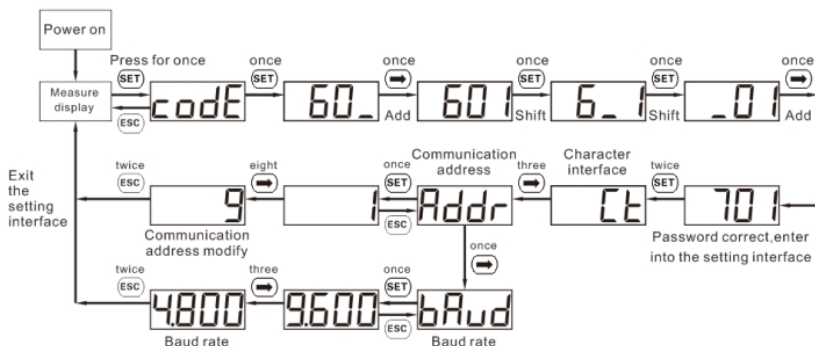

Figure 4-43 Meter configuration

The control modes of the generator function are similar to the manual and automatic modes of the smart load function, as shown in the table below:

Control Mode	Generator Strat Condition	Generator Stop Condition	Description
Manual	Manually enabled via the App	Manually disabled via the App, or when the grid is restored APP	The user manually starts and stops the generator through the App. The inverter sends a start signal to the generator via the dry contact.
Battery Energy Control	Battery SOC drops below the configured Start SOC	Battery charges to the configured Stop SOC, or the grid is restored	Configurable parameters: <i>Generator Start SOC,</i> <i>Generator Stop SOC.</i>

- **When the grid is available:** The ATS is connected to the grid, and the system operates in normal grid-tied mode. The AC coupling relay is open to ensure that the generator remains off.
- During a grid outage: The ATS automatically switches to the generator. The generator does not start immediately. It will start when the user manually enables it via the App, or when the battery SOC falls below the configured start SOC.
- **When the grid is restored:** After grid restoration, the ATS does not switch immediately. It switches to the grid only after a preset delay. The inverter detects grid restoration through the smart meter, resumes normal grid-tied operation, and turns off the generator.
- **During generator operation:** In the App and Web energy flow diagrams, the grid icon and corresponding power readings will reflect the generator's output.

For the detailed steps of alternator, please refer to section 7.2.3 or section 8.3.1.2.

5. Inverter Commissioning

5.1 Pre-commissioning Checks and Preparation

5.1.1 Inverter Installation check

The inverter shall be firmly installed in a position convenient for operation and maintenance, with the installation space convenient for ventilation and heat dissipation, and the installation environment is clean and tidy.

5.1.2 Cable connection check

- Confirm that the protective grounding cable, DC cable, AC cable and communication cable are connected correctly and firmly.
- Confirm that the cable binding meets the wiring requirements, is reasonably distributed and free of damage.
- Ensure that unused through holes are provided with waterproof covers.
- Ensure that the used through hole is sealed.

5.1.3 Electric connection check

- Confirm that the voltage and frequency of the inverter on-grid connection point meet the grid connection requirements.
- Confirm whether the battery pack is connected normally.
- Test whether the voltage on AC side is normal.
- Test whether the open-circuit voltage at PV side is $\leq 1000V$.

5.2 Power on/off steps

The power on steps and power off steps are the same as follows:

1. Turn on/off ON-GRID circuit breaker.
2. Turn on/off BACK-UP circuit breaker.
3. Turn on/off PV switch.
4. Turn on/off BAT circuit breaker between inverter and battery.

5.3 Operating Mode

Inverters can automatically switch between various modes—such as Self Powered, Fully Fed, Emergency Charging, Forced Off-Grid, Pure PV Mode, and TOU function—based on the time period and system requirements. These modes and functions can be configured through the MatriCloud App, allowing for optimized operation tailored to specific needs and conditions. After logging into MatriCloud App local control interface, click Settings -> EMS Parameters -> SysRunMode to switch between various modes. In addition, you can configure parameters such as anti-reverse current, feed grid power limit, grid charge power limit, battery from grid start time, battery from grid end time, etc. as below. For more information, refer to specific *User Manual for MatriCloud App*.

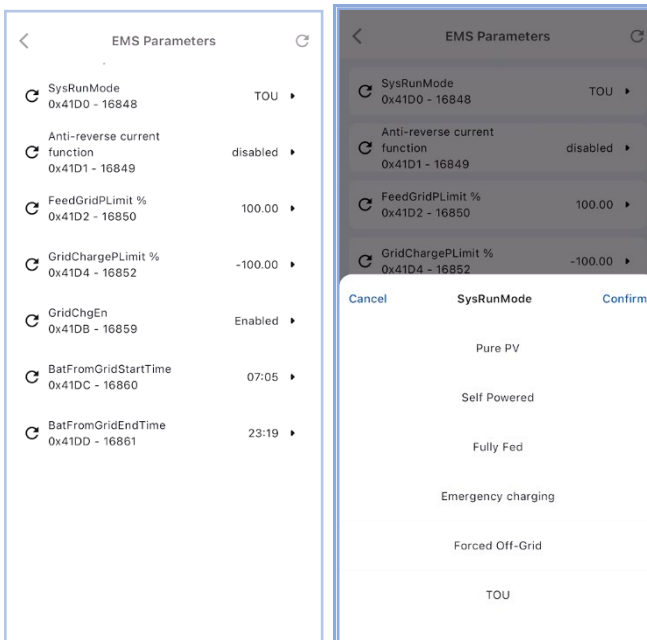

Figure 5-1 EMS Parameters

Parameter name	Description
SysRunMode	Including Self Powered, Fully Fed, Emergency Charging, Forced Off-Grid, Pure PV and TOU
Anti-reverse current function	Anti-reverse current (enabled or disabled)
FeedGridPLimit, %	Feed grid power limit percentage
GridChargePLimit, %	Grid charging power limit percentage
BatForGridLoadEn	Allows batteries to supply power for non-standby loads (only for Self Powered mode)
GridChgEn	Power grid charging (enabled or disabled);
BatFromGridStartTime	Starting time at which the power grid begins to charge batteries
BatFromGridEndTime	End time at which the power grid stops charging batteries

5.3.1 Self-Powered Mode

Self-Powered mode is applicable to areas with high electricity tariffs and little or no subsidies for solar power on-grid tariffs. PV supplies loads first, surplus generation charges battery and then feeds grid. When PV is insufficient, battery supplies power to loads first. If battery capacity runs low, grid continues to supply power. No battery discharge to the grid.

Day time	<ul style="list-style-type: none"> When the electricity generated in the PV system is sufficient, it will supply power to household loads first, the excess electricity is used for charging batteries, and the remaining electricity is sold to the power grid. When the electricity generated in the PV system is insufficient, battery power is prioritized for loads use. If battery power is insufficient, power grid will supply power to loads.
Night time	<ul style="list-style-type: none"> If the battery is fully charged, it supplies power to loads. If the battery is not fully charged, power grid and battery will jointly supply power to loads. If battery power is unavailable, grid will supply power to loads.

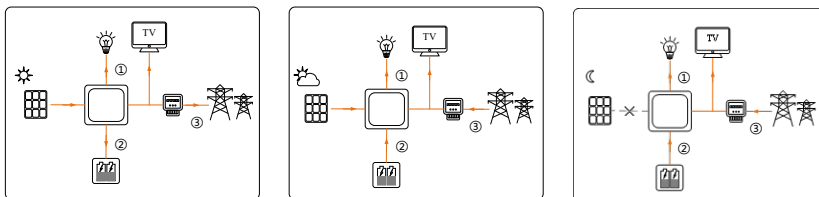

Figure 5-2 Schematic Diagram of Self Powered

Note:

- **Lithium battery:** If the SOC capacity is lower than backup SOC setting value, it will switch to the grid charging. Once the SOC power reaches the set value, grid will stop charging battery.
- **Lead acid battery:** If battery voltage is lower than the backup voltage, or battery has under-voltage alarm, grid will charge battery until the battery voltage recovers.

Additionally, the mode can be combined with the Peak Shaving function:

When Peak Shaving is enabled and both the **Peak Shaving Power** and **Peak Shaving Backup SOC** are configured, the system actively limits the maximum peak power drawn from the grid during peak periods, thereby reducing electricity costs.

- If the inverter is connected to and running with a generator, the Peak Shaving function will not take effect.
- When Battery SOC \geq Peak Shaving Backup SOC: Power is preferentially supplied to the load by PV and Battery. If PV and battery power are insufficient, power is drawn from the grid (if the power drawn from the grid exceeds the set Peak Shaving Power, normal power consumption remains permitted).
- When Battery SOC $<$ Peak Shaving Backup SOC: Power is preferentially drawn from PV and the Grid. If power is insufficient, the battery will provide the remaining power. If the power drawn from the grid exceeds the load power, the surplus power will charge the battery until it reaches the Peak Shaving Backup SOC.

5.3.2 Fully Fed Mode

It is recommended to use the Fully Fed mode in scenarios where there is a significant difference between peak-valley electricity prices. This mode is particularly suitable when the electricity price is high during the daytime.

The power supply scenario in the Fully Fed mode is as follows:

- When the tariff is at its peak and the PV system generates sufficient electricity, the PV system supplies power to household loads first. Any excess power is sold to the grid, while the remaining power charges the battery.
- When electricity prices are at their peak while the PV system generates insufficient electricity, the PV system and battery jointly supply power to the load, any excess energy can still be sold to the grid.

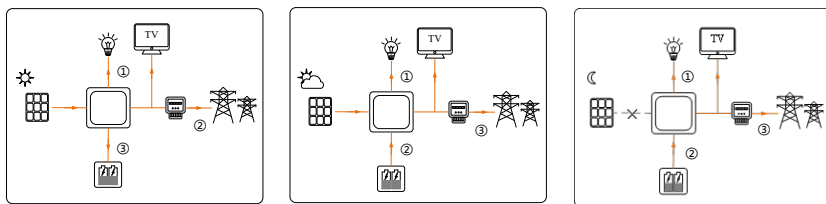

Figure 5-3 Schematic Diagram of Fully Fed

The following is the charging behaviors of different type of batteries in the Fully Fed mode:

- Lithium battery: If the SOC capacity is lower than backup SOC setting value, it will switch to the grid charging. Once the SOC power reaches the set value, grid will stop charging battery.
- Lead acid battery: If battery voltage is lower than the backup voltage, or battery has under-voltage alarm, grid will charge battery until the battery voltage recovers.

5.3.3 Emergency Charging Mode

This mode is for emergency charging in bad weather. Charge battery fully as quickly as possible and then left to stand (Keep from discharging) until it enters off-grid operation, or switches to another mode.

The power supply scenario in the emergency charging mode is as follows:

- When the PV system generates sufficient electricity, the electricity generated will first charge the battery, any excess electricity is used to supply loads, the remaining electricity is sold to the power grid.
- When the PV system generates insufficient electricity, the PV system and the grid jointly charge the battery.
- When no electricity is generated by the PV system: If the power grid is operating normally, it can supply power to the loads. If the power grid is abnormal, the inverter will enter off-grid mode, and the battery will supply power to the loads.

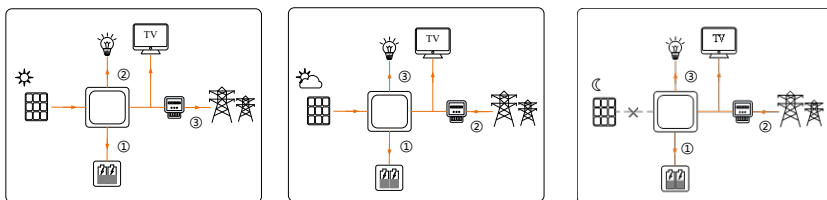

Figure 5-4 Schematic Diagram of Emergency charging

5.3.4 Forced Off-Grid Mode

The forced off-grid mode is mainly applicable to scenarios where the power grid is unstable, grid disconnection is frequent, while there are important loads, and no interruption is allowed.

This mode cannot be affected by grid stability and can make load run stably.

The conditions for switching from on-grid operation to forced off-grid mode are as follows:

- For lithium batteries: State of Charge (SOC) greater than 40%.
- For lead acid batteries: Battery voltage higher than the recovery voltage of the battery under-voltage alarm.

The conditions for switching from forced off-grid mode to on-grid operation are as follows:

- For lithium batteries: SOC less than 20%.
- For lead acid batteries: If battery voltage is lower than the backup voltage, or battery has under-voltage alarm.

When the battery voltage is low or battery is under-voltage, grid will charge battery until the battery voltage recovers. When the PV power is enough, the

battery under-voltage alarm will disappear and when SOC>40%, inverter will be in forced off-grid mode again.

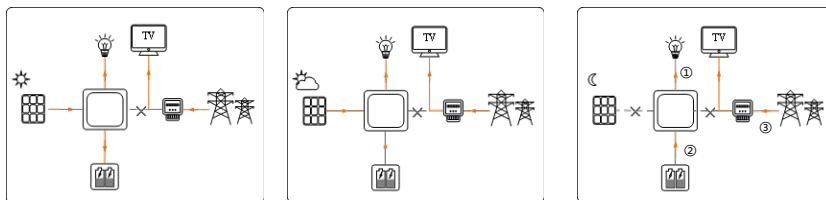

Figure 5-5 Schematic Diagram of Forced Off-Grid

5.3.5 Pure PV Mode

The application scenarios of the Pure PV Mode are as below:

- For customer who does not have batteries, the Hybrid inverter can work like a normal PV inverter with its working mode set as Pure PV Mode.
- For Hybrid inverter used together with battery: customer may stop/reduce battery charging/discharging to extend battery life in winter; or reduce the number of discharging if electricity price is low when using the TOU function.

When the PV generates sufficient electricity, it will supply power to grid and load at the same time. When the PV does not generate electricity, the grid will supply power to load. When the battery SOC is low, PV system and the grid will charge battery to SOC preset value.

- Lithium battery: If the SOC capacity is lower than backup SOC setting value, it will switch to the grid charging. Once the SOC power reaches the set value, grid will stop charging battery.
- Lead acid battery: If battery voltage is lower than the backup voltage, or battery has under-voltage alarm, grid will charge battery until the battery voltage recovers.

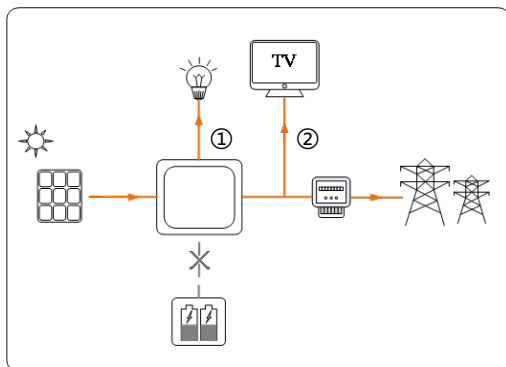

Figure 5-6 Schematic Diagram of Pure PV Mode

5.3.6 TOU

After enabling TOU (Time of Use) function, users can create typical daily scenarios and assign specific basic modes—such as Self Powered mode, Fully Fed mode, emergency charging mode, and Pure PV Mode—to different time slots. These scenarios can be categorized by week and adjusted according to seasonal operation rules. Additionally, unique strategies can be set for holidays throughout the year.

6. App Local Control

IMPORTANT:



- Complete above commissioning and inspection before operation, to confirm that there is no error.
 - Both AC and DC sides of the inverter shall have been powered on.
 - Viewing distance between mobile phone and inverter shall be kept within 5m, to ensure good communication quality.
 - Open the Bluetooth function on your phone at first and the inverter can only pair with one Bluetooth at a time, which means only mobile phone can connect with the inverter successfully at one time.
 - When updating inverter through the app, the inverter will stop generating power for 3-5 minutes.
-

6.1 App Download

User can download the "MatriCloud " app from the app store (available in the Apple Store for iOS devices or the Google Store for Android devices) or directly download it by scanning the provided QR code. The app is compatible with Android 7.0 and iOS 13.0 or higher phone system.



6.2 App Connection and Setting

Users can perform the following procedures to set the APP easily. First, open the Bluetooth function on your phone.

1. Open the MatriCloud App. Tap setting icon in the top right corner. Select right server and language.

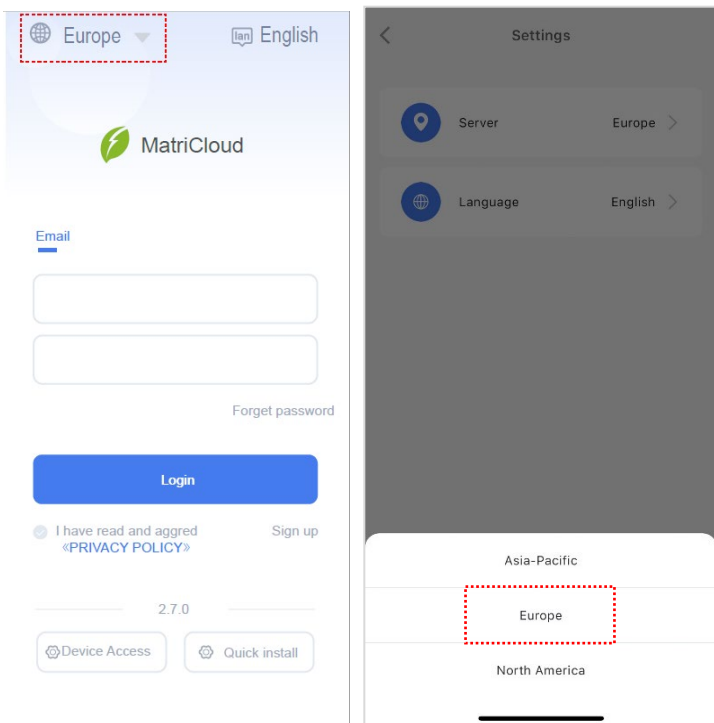

Figure 6-1 Configure the server and language

2. Tap "Quick Install" and then "Bluetooth Connect" button to open the device name list. Choose the correct device name.

Note: The device name "XXXXXXXX" is the last 8 digits of SN on the WIFI module label.

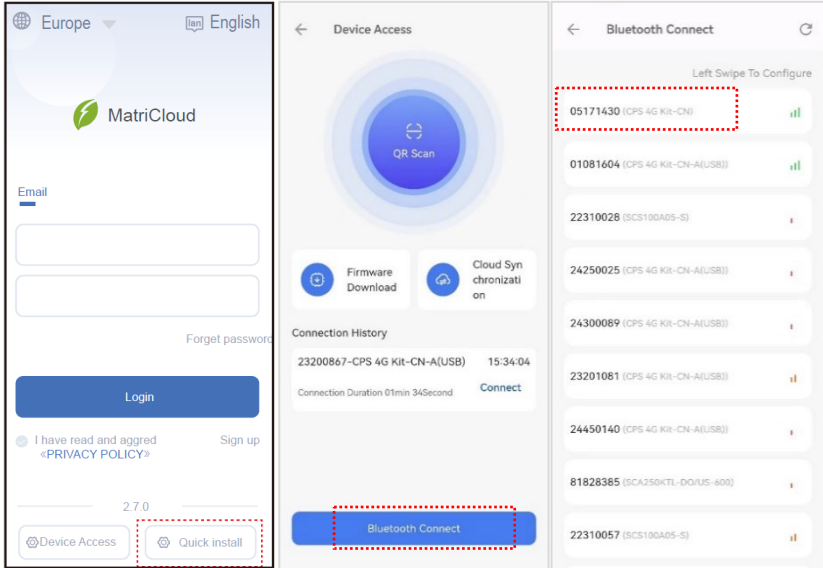

Figure 6-2 Connect to inverter

3. When APP is successfully connected to inverter, “Installation Setting Wizard” page will pop out. Check if all the cables are connected correctly and tap “Next Step”.

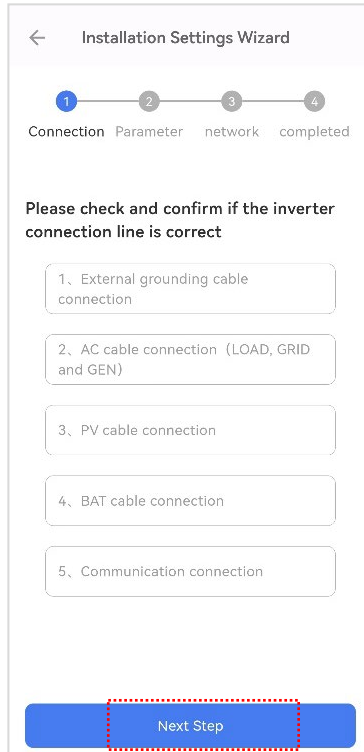

Figure 6-3 Connection Check

- On parameter configuration page, set grid information (code, type, frequency, sampling), parallel connection mode (local address, number of units), equipment access (cell type, generator) and operation mode (max. on-grid power, standby power SOC, charging period etc.), and tap “Next Step”.

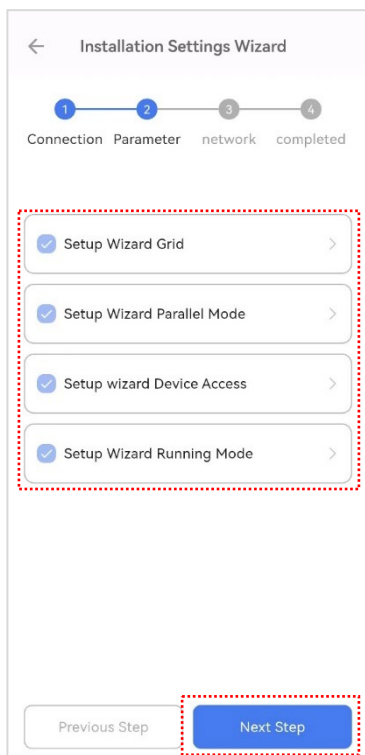

Figure 6-4 Parameter Configuration

- On network configuration interface, tap “Select” to select the target Wi-Fi and then enter password to finish network configuration. Tap “Next Step” to continue.



← Installation Settings Wizard

1 — 2 — 3 — 4
Connection Parameter network completed

Network Connection Configuration:
Please confirm if the communication stick has 4G function, otherwise select Wi Fi connection, please confirm that the communication stick STA indicator light is flashing.
**The standard communication rod of the inverter does not have 4G function.*

Wi-Fi

CPS-VIP

chintpower7788

4G

Figure 6-5 Network Configuration

6. Tap **“Finish and power on”** to complete the Quick Install wizard.

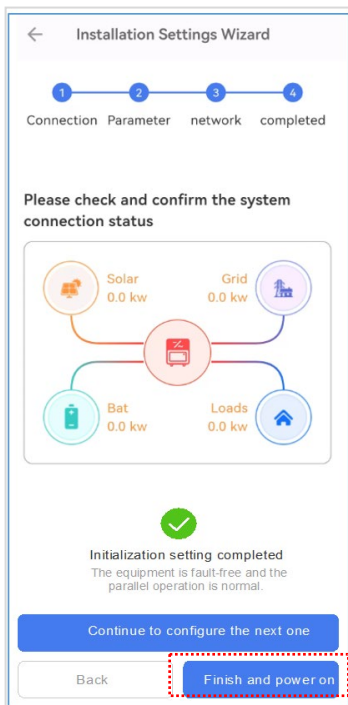

Figure 6-6 Complete Configuration

7. Tap "Device Access" and then "Bluetooth Connect" button to connect to inverter again (refer to step 2), then you will enter Home page.

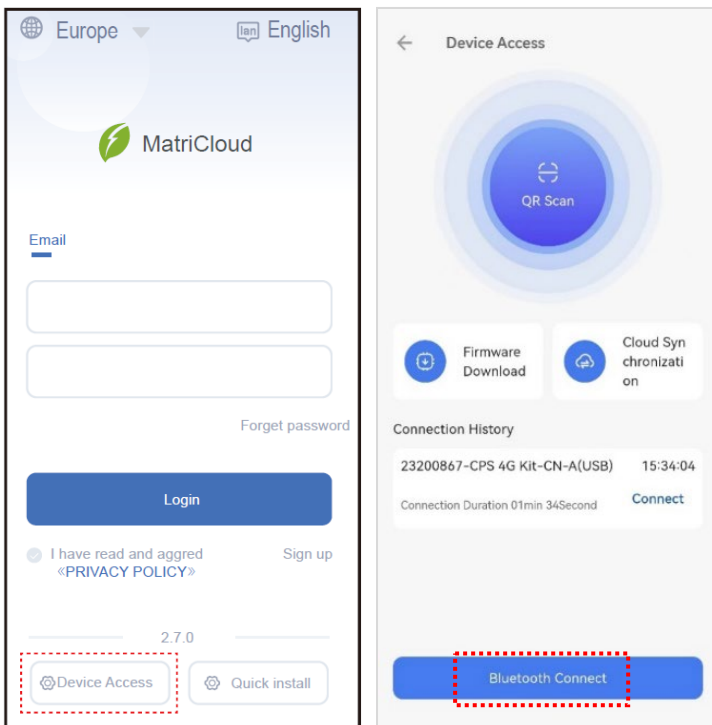

Figure 6-7 enter Home page

- Tap the “Settings” button, enter the password “1111”, you will be directed to the setting interface. On “Input Register Map” part, you can read only relevant parameters. On “Hold Register Map” part, you can set and modify parameters as required.

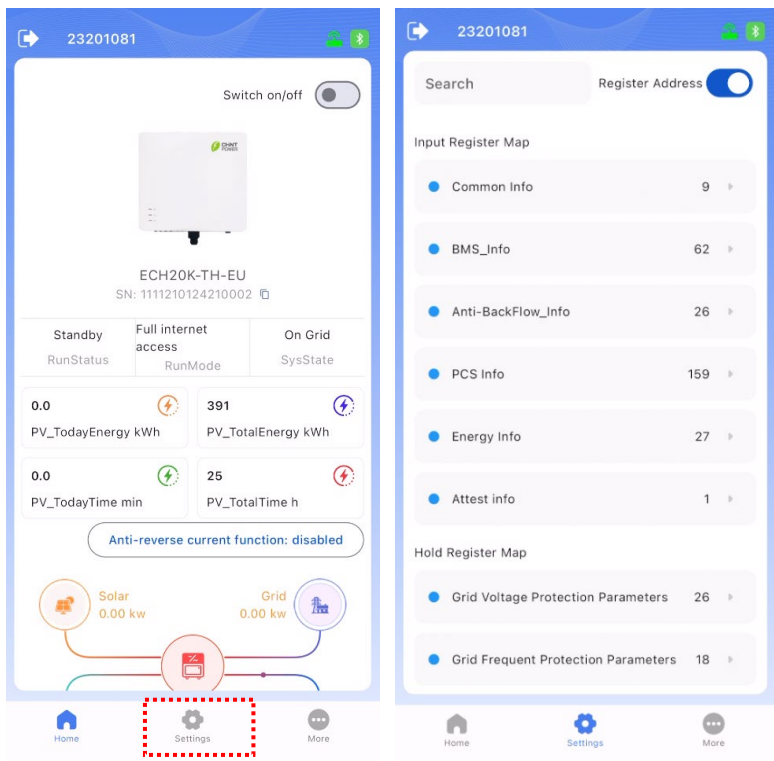

Figure 6-8 Setting interface



NOTICE

Register parameters must be modified according to the communication protocol under the guidance of the engineer. Please contact our service personnel if any problem.

9. If any fault, you can tap “More” button to see fault history and clear the fault. In addition, you can also find more other function here.

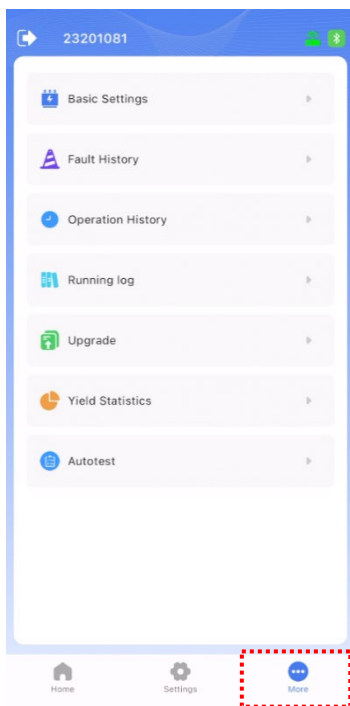

Figure 6-9 More interface

IMPORTANT:



- For more detailed information, please refer to specific user manual for European Hybrid Inverter MatriCloud APP.
-

7. App Remote Control

7.1 Sign up and Login

1. Open the MatriCloud App and tap the setting icon in the top right corner, select Europe server and language.

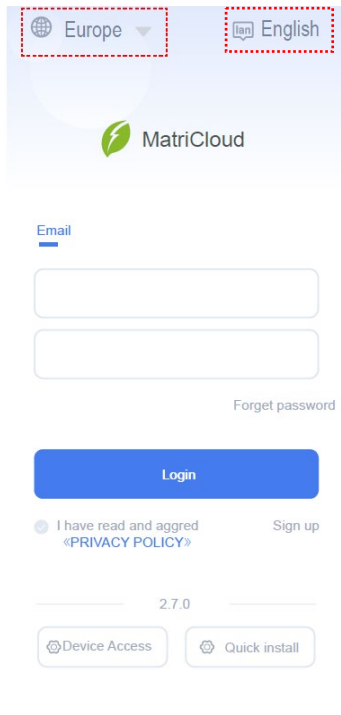

Figure 7-1 Choose Server Area and Language

2. Tap "Sign up" and follow tips to register an account.

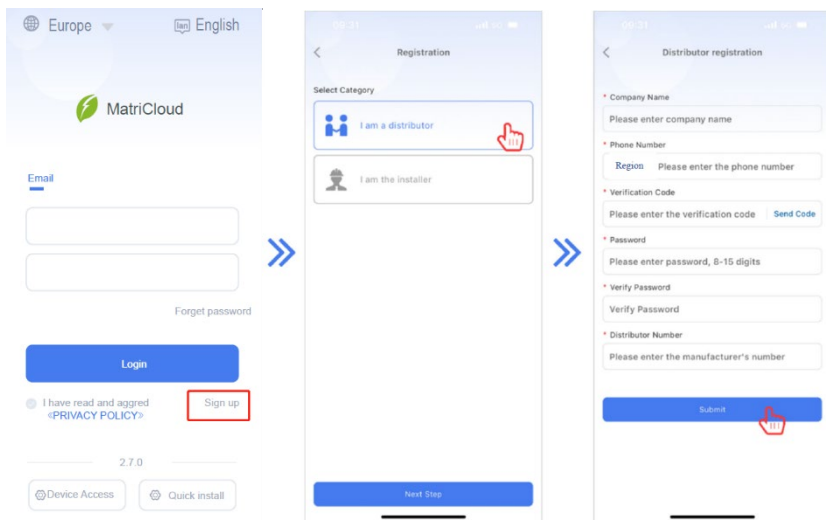

Figure 7-2 Sign Up

IMPORTANT:



- The account types include distributor and installer. Both account types can assist the owner user in creating sites, managing installed and operated sites, and maintained sites, maintenance, and managing users and organizations.
- Distributor number can only be obtained by contacting your superior distributor/installer.

3. Login in MatriCloud APP with the account registered. You will be directed to the Home Page Interface.

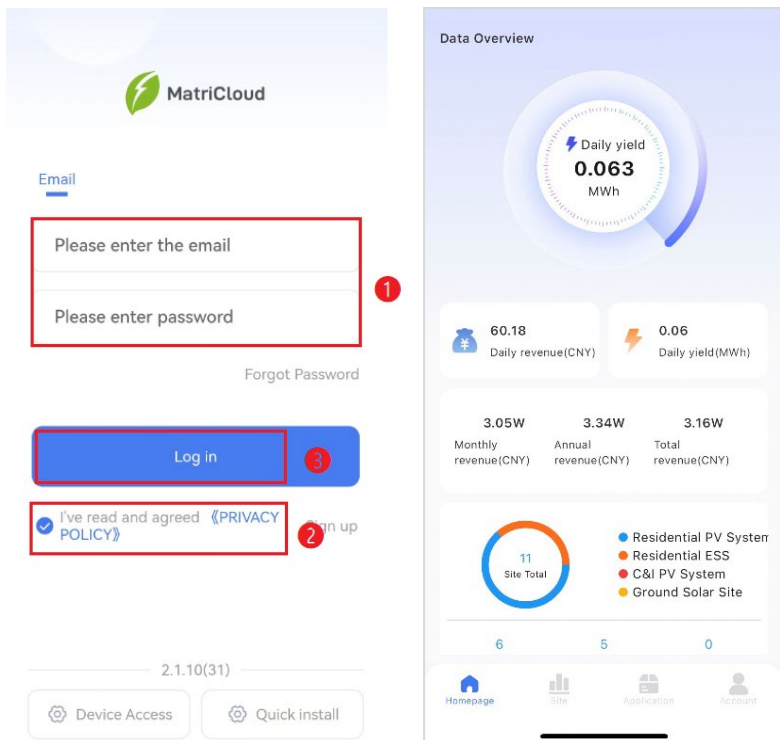

Figure 7-3 Log in

7.2 Site

Click bottom “Site” menu to visit site list. Here you can create site, achieve AC coupling and other functions.

7.2.1 Create Site

1. Tap “+” button to create a new site.

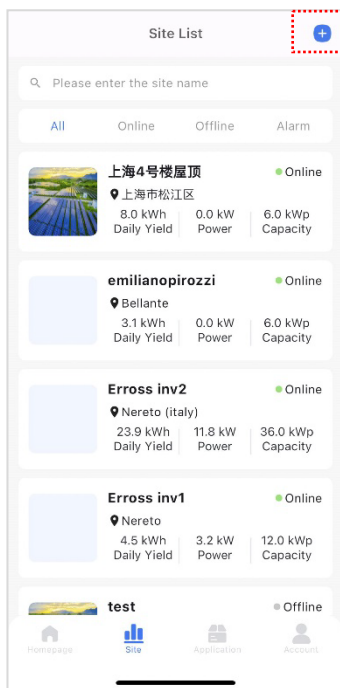

Figure 7-4 Create Site

2. Tap the "Scan to add device" button to scan the barcode on the stick, then tap "Confirm".

Note: If the barcode cannot be scanned, you can also enter the stick SN number manually.

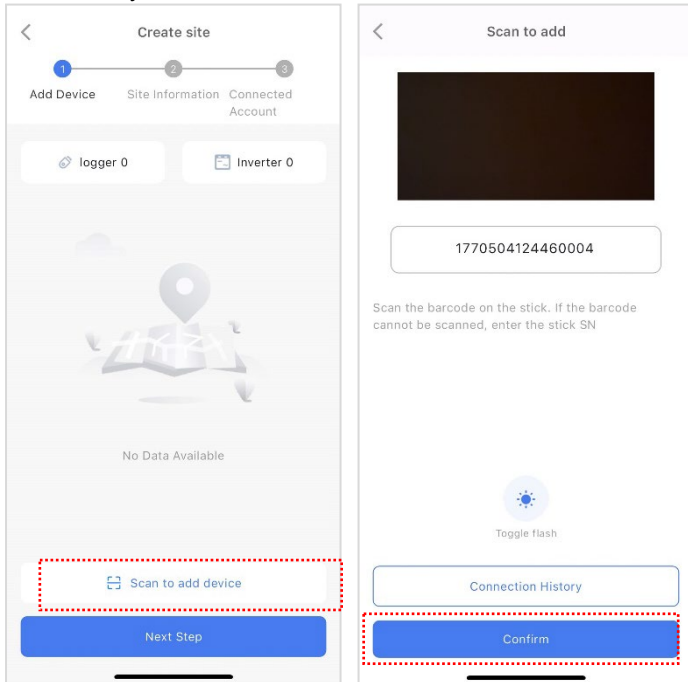
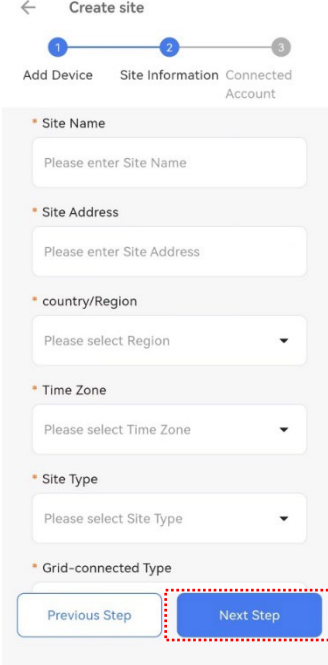

Figure 7-5 Scan to add device

3. Fill in all the necessary site information, then tap "Next Step".



← Create site

1 2 3

Add Device Site Information Connected Account

- * Site Name
Please enter Site Name
- * Site Address
Please enter Site Address
- * country/Region
Please select Region
- * Time Zone
Please select Time Zone
- * Site Type
Please select Site Type
- * Grid-connected Type

Previous Step Next Step

Figure 7-6 Fill in site information

4. Tap “Select Connected Account” to choose an existing account, then tap “Create” to create site. Or you can create a new count by entering all the necessary information step by step and then tap “Create” to create a site.

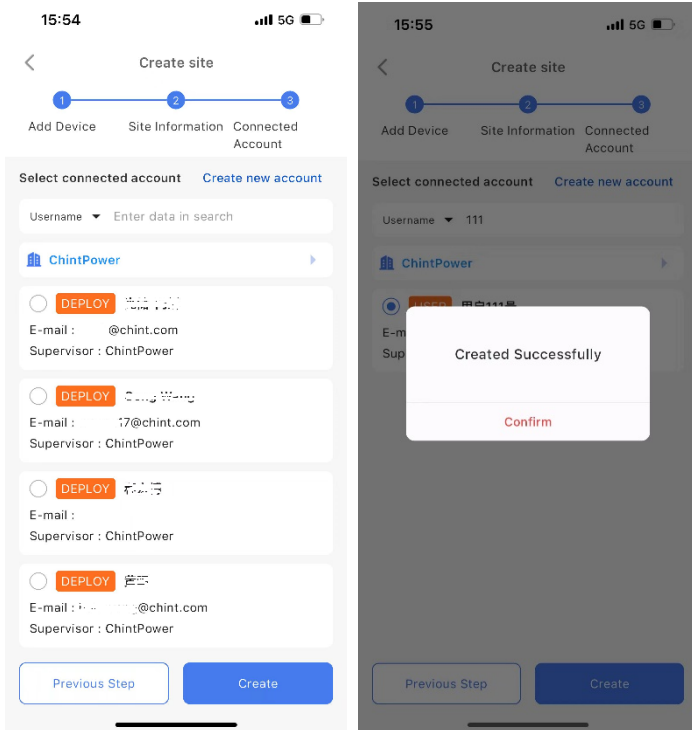

Figure 7-7 Create a site

7.2.2 AC Coupling

On “Site list” page, choose one ESS site > click “Device” menu>click “Inverter” submenu, and then click “...” icon and choose “AC Coupling” in the pop-up checkbox (as shown in fig. 7-8). Select target PV inverters and confirm, PV inverters will be coupled.

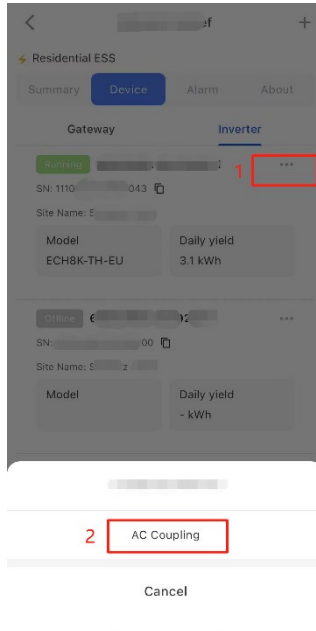

Figure 7-8 AC Coupling

The AC Solar meter enable steps are as below:

1. Click “Account” menu > “Device Access” to connect inverter by Bluetooth (refer to section 6.2 App Connection and Setting) and enter homepage. Click “Settings -> System Configuration Parameters -> AC Solar Meter En -> Enable” in Matricloud APP.
2. Configure meter addresses: The two meters need to be configured with different addresses. For example, METER 1 (grid meter) and METER 2 (AC Solar meter) in the figure are set as 1 and 2 respectively. The address of each meter shall be the same as that of the inverter.

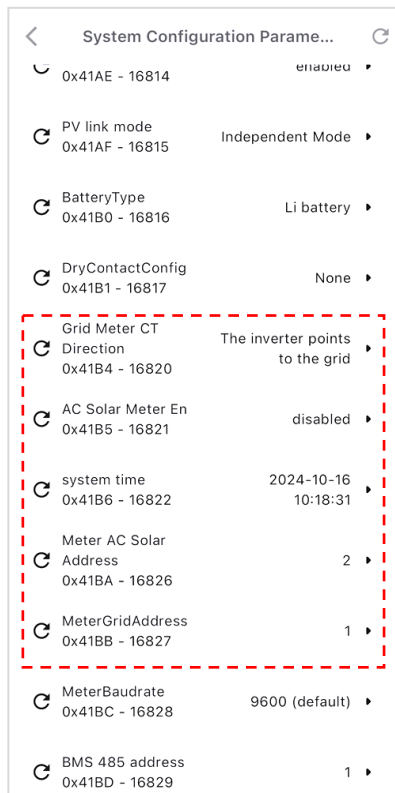

Figure 7-9 Configure meter addresses by APP

Configure addresses of both energy meters according to the following steps

and diagram. NOTE: Each meter must have a unique address. Ensure that the meter is connected to the grid and powered on before modifying any parameters.

3. Press the “SET” button on meter panel.
4. Input password “701” to access setting function.
5. Select target parameter and navigate to relevant setting.
6. Check the AC-Coupled meter address: If it matches the default value 2, you can exit directly. If not, you can:
 - Modify the inverter’s address to match the meter’s address. Or change the meter address to the default value 2 via the meter panel.
 - Check the Baud Rate: the default baud rate is 9600. Ensure that the baud rate of both the grid-side meter and the AC-coupled meter are the same.

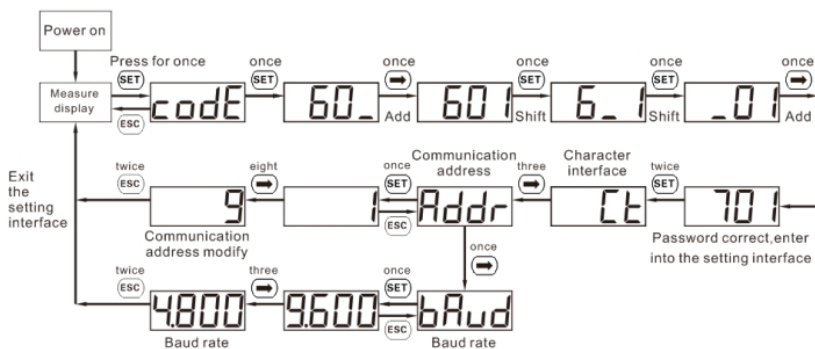

Figure 7-10 Diagram of meter configuration

7.2.3 Generator

Follow the steps below to enable the generator function:

1. Go to Account -> Device AccessConnect the inverter via Bluetooth (refer to Section 6.2 App Connection and Setting), then navigate in the MatriCloud App to *Settings* ->*Load Control Parameters* ->*Output the dry contact configuration*. Change the setting to "Generator Control", or select either "Manual Control" or "Battery SOC Control" as your operational needs.

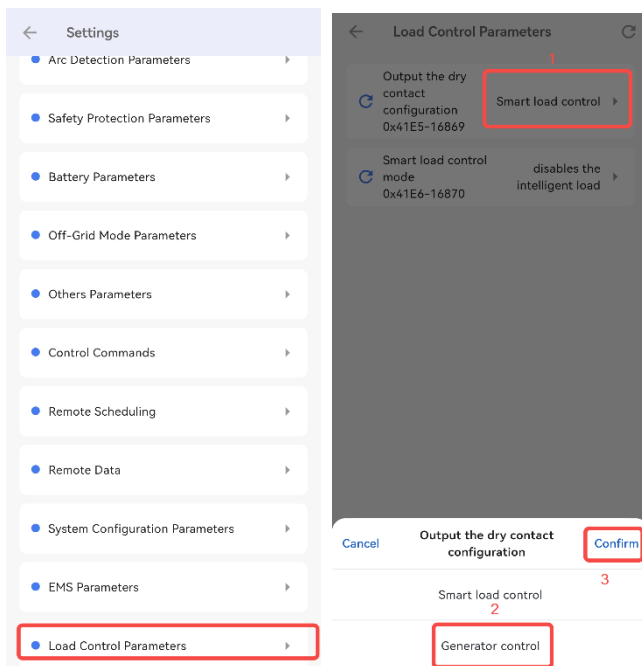

Figure 7-11 Enable the Generator Function

2. Configure meter addresses: The two meters need to be configured with different addresses. For example, METER 1 (Grid meter) and METER 2 (Generator Meter) in the figure are set as 1 and 2 respectively. The address of each meter shall be the same as that of the inverter.

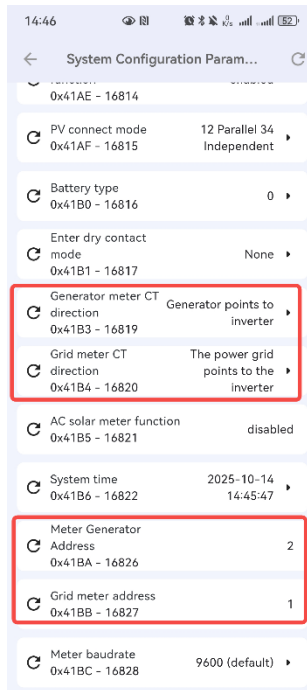
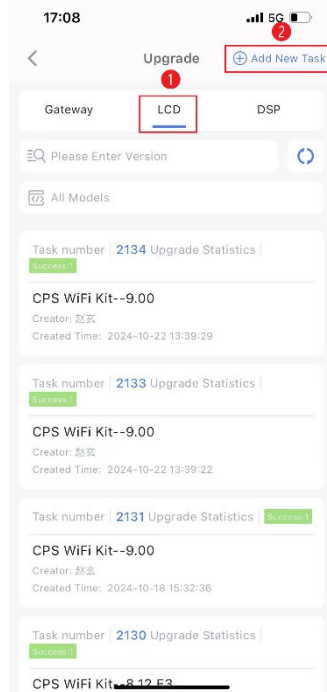
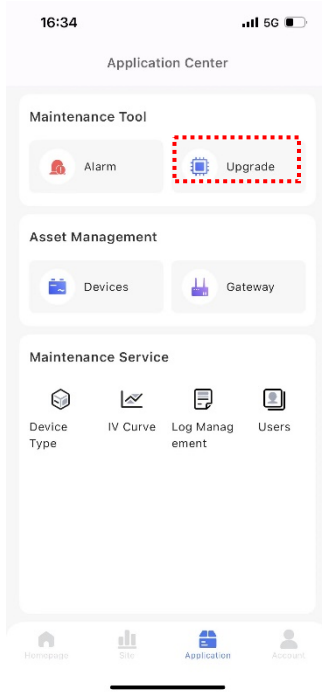

Figure 7-12 Configure meter addresses by APP

7.3 Application – Remote Upgrade

Application interface provides operations such as device maintenance, asset management and maintenance services. Here you can also upgrade firmware as below.

1. Tap "Upgrade" button
2. Choose item to be upgraded, and tap "+Add New Task" button in the upper right corner.
3. Select the model and firmware to be upgraded, and whether to make an appointment for upgrade, and then tap "Next Step" button.
4. Select the device to be upgraded (single or multiple choices), and click "Confirm Submission" to create an upgrade task.



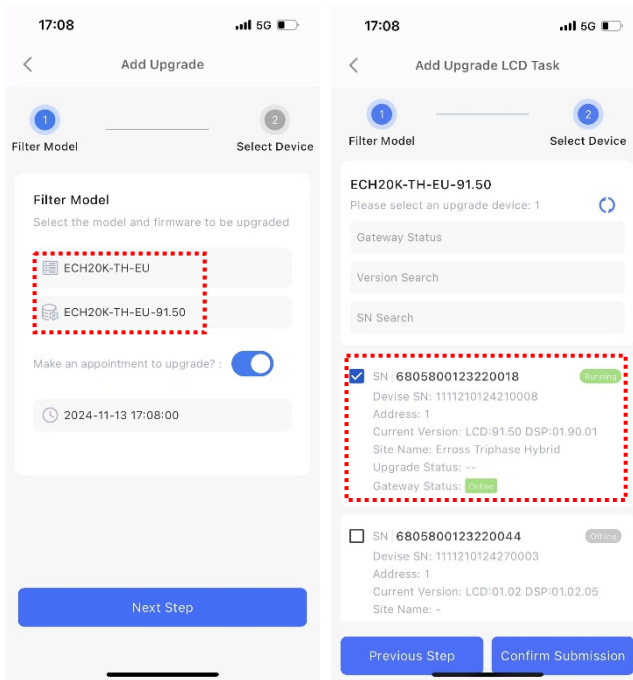

Figure 7-13 Create an Upgrade Task

7.4 Account

In the Account interface, you can modify account information, adjust security settings, log out, access general settings, and view software information. Click “Device Access” item, you can enter the local control interface.

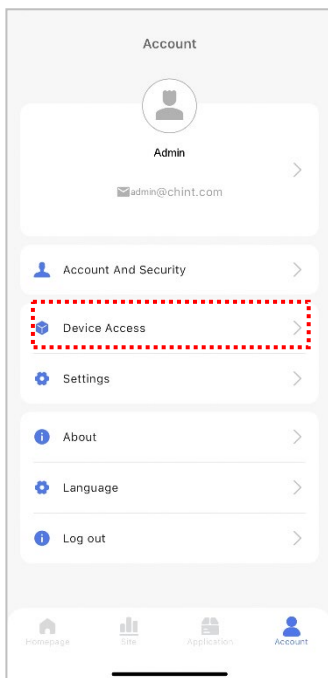

Figure 7-14 Account

8. Cloud Platform Introduction

8.1 System Login

8.1.1 Registration and Login

Who can create account? users who provide the owner with services such as site construction, operation, and maintenance.

Methods for signing up: 1) contact the superior company for registration assistance; 2) self-registration.

Self-registration process are as follows:

1. To access the login page, please navigate to the provided website: <https://eu.chintpower.com>.
2. Click “Sign Up Now” to access the registration page.

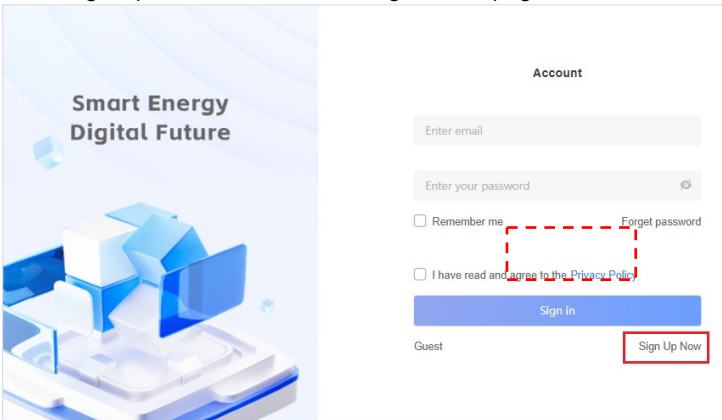
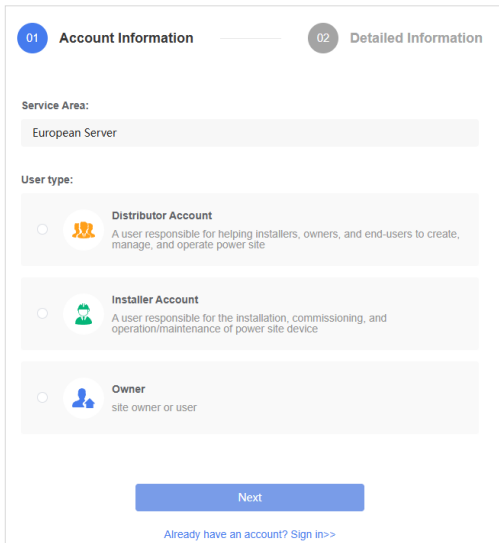

Figure 8-1 Sign up

3. Select your account type (Distributor or Installer Account), click “Next” to fill in your registration information.



01 Account Information ——— 02 Detailed Information

Service Area:
European Server

User type:

Distributor Account
A user responsible for helping installers, owners, and end-users to create, manage, and operate power site.

Installer Account
A user responsible for the installation, commissioning, and operation/maintenance of power site device.

Owner
site owner or user

Next

[Already have an account? Sign in->](#)

Figure 8-2 Select account type

4. Fill in the registration information. Agree to the Privacy Policy, and click “submit” to complete the registration.

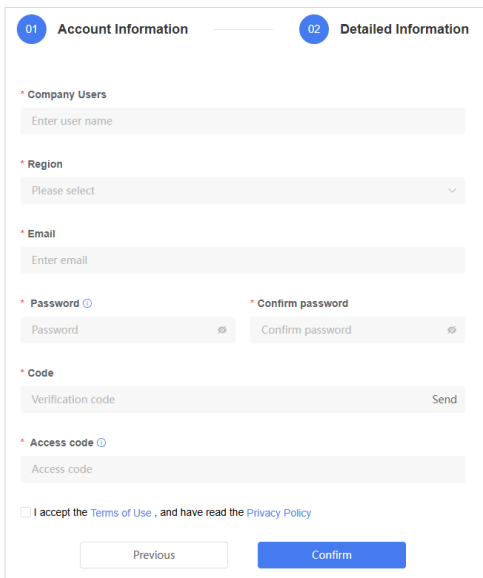

01 Account Information ——— 02 Detailed Information

* **Company Users**
Enter user name

* **Region**
Please select

* **Email**
Enter email

* **Password** Password **Confirm password**
Confirm password

* **Code**
Verification code Send

* **Access code** Access code

I accept the [Terms of Use](#) , and have read the [Privacy Policy](#)

Previous Confirm

Figure 8-3 Distributor account information

**IMPORTANT:**

Access Code is organization code of superior service provider. It can be obtained by contacting your superior service provider. After filling in, your superior service provider can browse and manage the site you managed.

5. Go back to sign in page. Fill in account and password. Click “Sign in” to enter the management page.

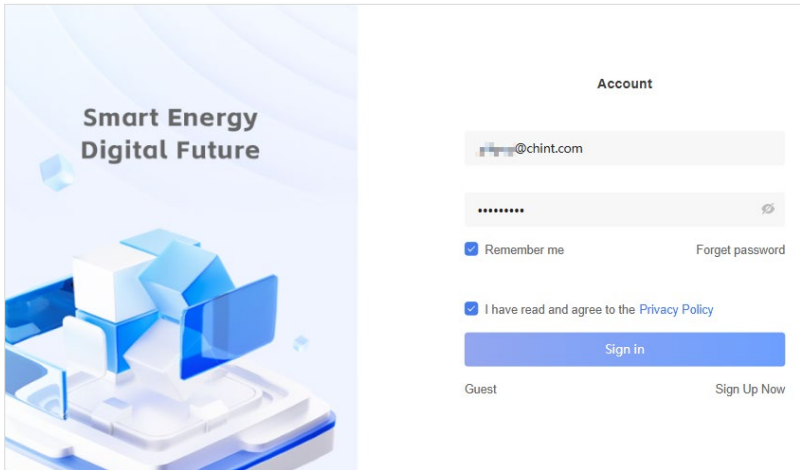

Figure 8-4 Access the management page

8.2 Account Management

By clicking on the left navigation menu "Account>Company", you can manage companies and users.

8.2.1 Add Company

Click "Add company " button and then fill in all necessary information to add a company.

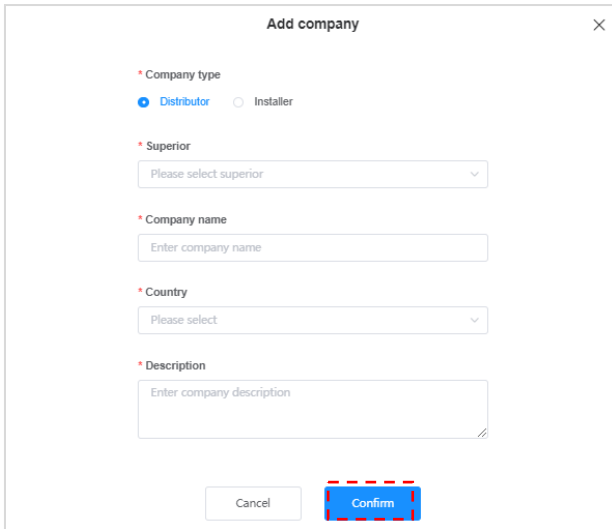
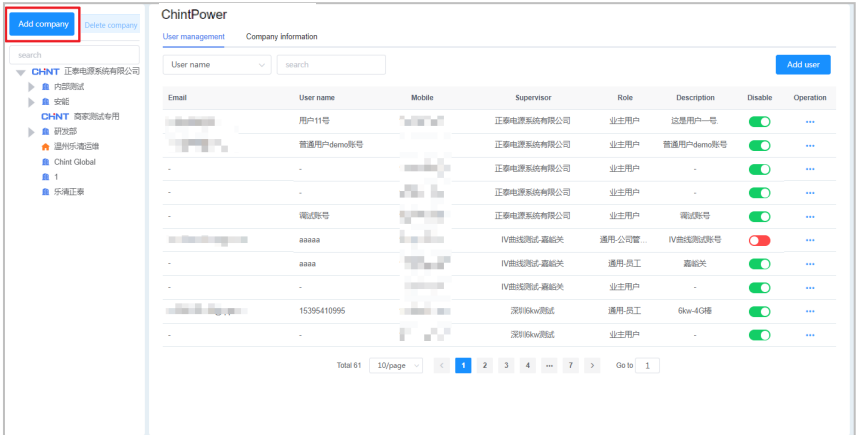

Figure 8-5 Add a company

8.2.2 Add User

Click "Add User" button to enter the "Add user" interface, fill in necessary information and select a correct role to add a user.

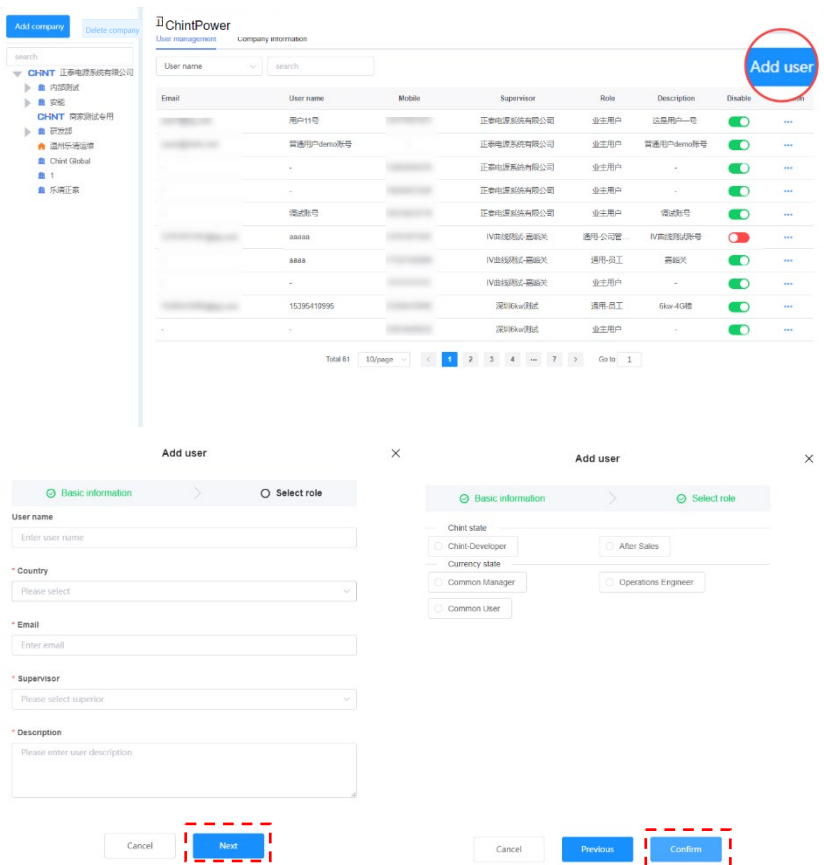

Figure 8-6 Add a user

8.3 Site Management

8.3.1 Site

By clicking on the left navigation menu "Site Management>Site", you can visit existing site under the site list or create site.

8.3.1.1 AC Couple

Following steps 1-4 as below to couple PV inverters.

1. Click site name link (ESS) under the site list to visit the site.

Site list Optional [Create Site](#)

Select superior account: All status Search by site name Search user [Search](#)

Site status	Site name	Site Type	Username	Region	Offline rate	Capacity	Power generation	Power generation day	Affiliated company	Operation
Normal	1	Residential ESS	ut	Pakistan	100%	17.5 kWp	0 kW	23.8 kWh	Power Zone	...
Normal	2	Residential ESS		Pakistan	100%	17.5 kWp	9.73 kW	23 kWh	Power Zone	...
Normal	3	PV Utility	Al	Turkey	82%	16100 kWp	7503.3 kW	16872.4 kWh	Gataawhd TR	...
Normal	4	Residential ESS		Pakistan	100%	20 kWp	16.14 kW	59.5 kWh	Power Zone	...

Figure 8-7 Click site name

2. Click “AC Couple”

Gateway **Inverter** [Add Gateway](#)

Enter inverter SN to search

Status	Inverter SN	Device model	Address	Gateway SN	Firmware	Current power	Power generation	Operation
Normal	02	ECH20K-TH-EU	1		DSP: 01.02.71 LCD: 02.40	0 kW	23.8 kWh	AC Couple Delete

Figure 8-8 Click “AC Couple”

3. Select the coupled device (PV inverters).

AC Couple

*Note: Only energy storage devices are supported to initiate coupling, and photovoltaic devices are only coupled objects. There is no limit on the number of coupled devices.

Status	Inverter SN	Gateway SN	Address	Device model
Running		3	1	ECH20K-TH-EU

Coupled device [Select the coupled device](#)

Status	Inverter SN	Gateway SN	Address	Device model	Operation
No Data					

Figure 8-9 Select the coupled device

4. The coupled devices will be shown below.

AC Couple

*Note: Only energy storage devices are supported to initiate coupling, and photovoltaic devices are only coupled objects. There is no limit on the number of coupled devices.

Status	Inverter SN	Gateway SN	Address	Device model
Running		18	1	ECH20K-TH-EU

Coupled device [Select the coupled device](#)

Status	Inverter SN	Gateway SN	Address	Device model	Operation
Standby	1		1	SCA40K-T-EU	Decouple
Standby	2		2	SCA40K-T-EU	Decouple

Figure 8-10 Successful coupling

Then enable AC coupling energy meter following the steps below.

1. Click inverter SN to enter the inverter details page.

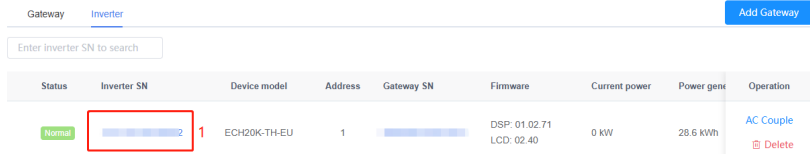

Status	Inverter SN	Device model	Address	Gateway SN	Firmware	Current power	Power gen	Operation
Normal	1	ECH20K-TH-EU	1		DSP: 01.02.71 LCD: 02.40	0 kW	28.6 kWh	AC Couple Delete

Figure 8-11 Click inverter SN

2. Click “Settings”, then click the “Quick Search” button to switch to “Group Search”. Choose “System Configuration Parameters” register group.

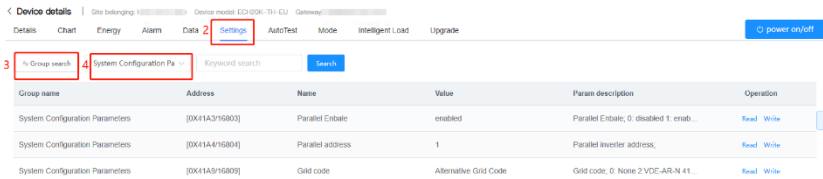

Group name	Address	Name	Value	Param description	Operation
System Configuration Parameters	[0X41A316803]	Parallel Enable	enabled	Parallel Enable; 0: disabled 1: enab...	Read Write
System Configuration Parameters	[0X41A416804]	Parallel address	1	Parallel inverter address;	Read Write
System Configuration Parameters	[0X41A316809]	Grid code	Alternative Grid Code	Grid code; 0: None 2: VDE-AR-N 41...	Read Write

Figure 8-12 Settings

3. Write to the “AC-Coupled Meter Enable Register” to enable it. Then check the “CT Direction” of the AC-coupled meter, the “AC-Coupled Meter Address”, and the “Meter Address”.

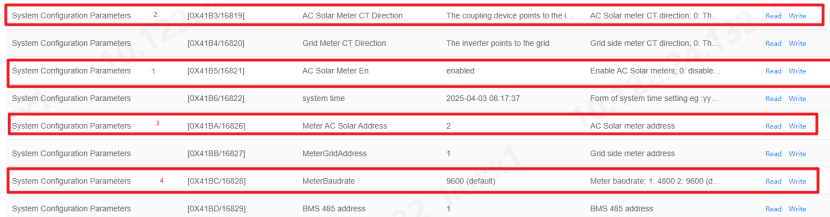

System Configuration Parameters	[0X41B316819]	AC Solar Meter CT Direction	The coupling device points to the I	AC Solar meter CT direction; 0: Th...	Read Write
System Configuration Parameters	[0X41B416820]	Grid Meter CT Direction	The inverter points to the grid	Grid side meter CT direction; 0: Th...	Read Write
System Configuration Parameters	[0X41B516821]	AC Solar Meter En	enabled	Enable AC Solar meters; 0: disable...	Read Write
System Configuration Parameters	[0X41B616822]	system time	2025-04-03 08:17:37	Form of system time setting eg. yy...	Read Write
System Configuration Parameters	[0X41B416826]	Meter AC Solar Address	2	AC Solar meter address	Read Write
System Configuration Parameters	[0X41B116827]	MeterGridAddress	1	Grid side meter address	Read Write
System Configuration Parameters	[0X41B116828]	MeterBaudrate	9600 (default)	Meter baudrate; 1: 4800 2: 9600 (d...	Read Write
System Configuration Parameters	[0X41B116829]	BMS 485 address	1	BMS 485 address	Read Write

Figure 8-13 enable AC-Coupled Meter Register

4. Configure the addresses of both energy meters. Each meter must have a unique address. Detailed diagram, refer to Figure 7-10 Diagram of meter configuration in section 7.2.2 AC Coupling.

8.3.1.2 Create site

You can also click "Create Site" button and then follow tips to create a new site.

The screenshot shows the 'Site Management' section of the CHNT Cloud Platform. On the left, a sidebar menu has 'Site Management' selected, with 'Site' highlighted. The main dashboard displays various metrics: 127 total sites, 5927 total devices, and power generation/revenue statistics. A 'Site list' table is visible below the dashboard. A red box highlights the 'Create Site' button in the top right corner of the dashboard. Below the dashboard, a 'Create Site' modal dialog is shown with a three-step process: 1. Add collector, 2. Site info, and 3. Account information. A text input field with the placeholder 'Please enters' and a 'Remove' button is present. Below the input field is an 'Add collector' button. At the bottom of the modal are 'Cancel' and 'Skip' buttons.

Figure 8-14 Create Site

8.3.2 Inverter

By clicking "Inverter" button and then name or device SN, you can visit more functions, or touch "Power on/off command" button to power on/off inverter.

The screenshot shows the 'Inverter' page in the CHNT Cloud Platform. The left sidebar menu has 'Inverter' selected. The main area displays a table of inverter details. A red box highlights the 'Inverter' button in the sidebar. Another red box highlights a row in the table, specifically the 'Device SN' and 'Site name' columns for the first row.

Device status	Name	Device SN	Site name	Gateway SN	Equipment model	Firmware	Power generation	Power generation day	Operation
Online	9809090122220209	1111210164210004	Fujian	9809090122220209	LDI-GDK-111-EU	Ver: 01.02.04 Ver: 01.05.01	0 kW	0 kWh	20
Offline	6805000159150117	11103011510006	Campanian	6805000159150117	PC2H0K74-FU1	Ver: 01.05.03 Ver: 01.49	- kW	0 kWh	36
Online	9809090142220112	1110201124220003	Mechercham	9809090142220112	LDI-GDK-111-EU	Ver: 01.01.95 Ver: 01.49	0.46 kW	0.4 kWh	20
Online	9809090142220107	1109090104010003	-	9809090142220107	LDI-GDK-111-EU	Ver: 01.05.07 Ver: 06.35	-0.022 kW	0 kWh	20
Online	6805000149400303	1109090104010003	Mechercham	6805000149400303	PC2H0K74-FU1	Ver: 01.05.07 Ver: 06.35	0.166 kW	0 kWh	30
Online	480K	1110000164210000	Si-Ning (Shi)	9809090142220107	LDI-GDK-111-EU	Ver: 02.03.02 Ver: 05.02	1.2 kW	2.3 kWh	23
Online	6805000147100212	1110500104010000	Priska (Indo)	6805000147100212	LDI-GDK-111-EU	Ver: 01.05.05 Ver: 03.02	1.8 kW	3.7 kWh	30
Online	116941	1111210164210000	Si-Ning (Shi)	9809090142220107	LDI-GDK-111-EU	Ver: 01.05.07 Ver: 01.50	0.78 kW	1.7 kWh	23

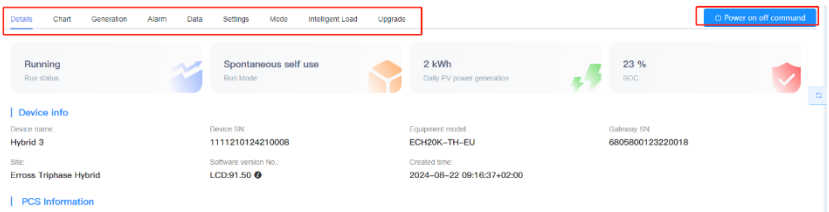

Figure 8-15 Visit inverter functions

8.3.2.1 Settings

Select the register group and enter the register name or keyword, then click “Enable quick search” or “Search” to search for register parameters that meet the requirements. Click the “Read” button in the operation column to read the current register information, and click the “Write” button to write the register information.

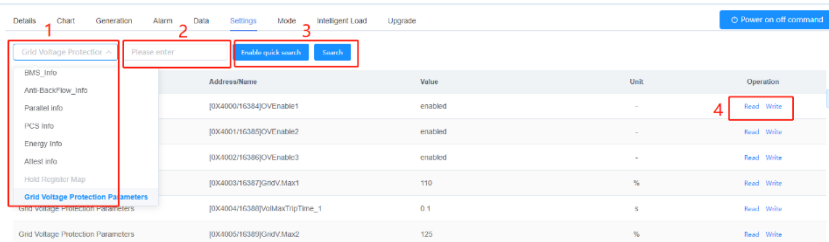
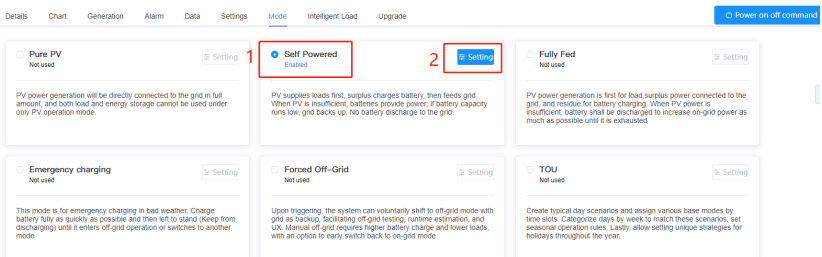

Figure 8-16 Setting

8.3.2.2 Mode

You can choose operation mode and then click “Setting” to set its detailed parameters.



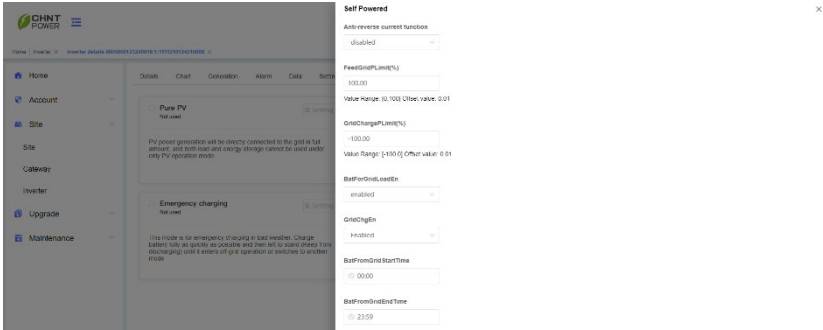

Figure 8-17 Operating Mode

8.3.2.3 Intelligent Load

You can choose suitable control mode and click “Setting” button to set parameters in the corresponding mode. Users can control the operation mode of the device to achieve expected control effects.

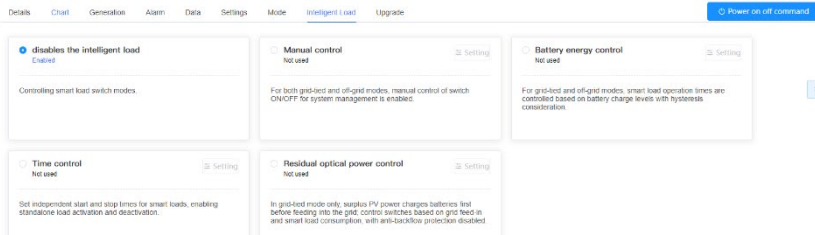

Figure 8-18 Intelligent load

8.4 Upgrade

By clicking on the left navigation menu "Upgrade> Firmware Update", you can upgrade firmware as follows.

8.4.1 Firmware Upgrade

1. Click “Firmware Update” menu to enter the Firmware Update page.
2. You can click any menu to select the upgrade items, such as Gateway, LCD, DSP or ARC, etc.
3. Select model or input version to search for a list of eligible firmware.
4. Click the "Add Task" button on the far left to add one single or multiple devices for upgrade.

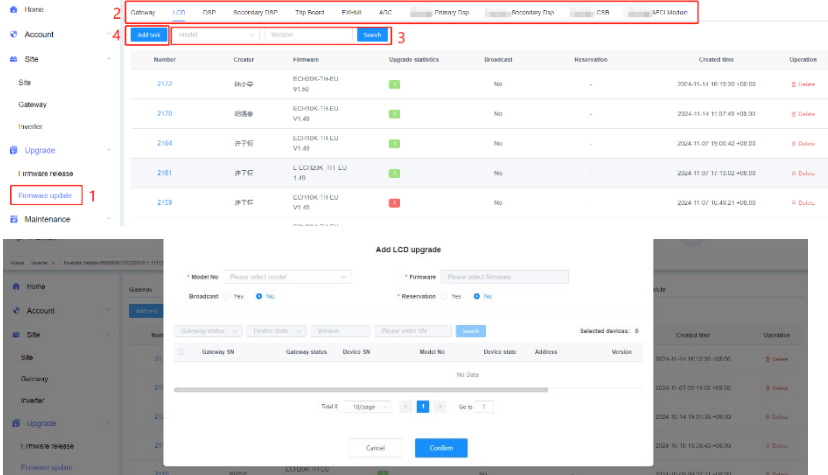

Figure 8-19 Add firmware upgrade task

9. Fault and Maintenance

9.1 Fault Analysis and Troubleshooting

Before contacting after-sales service, you can check the working environment of the inverter based on the following points, quickly locate the cause of the fault, and follow the recommended troubleshooting methods.

1. Internal information of the inverter: You can view the occurrence time and frequency of the fault through the APP or webpage, and handle it according to the corresponding "Solution" based on the "Fault Description", as shown in the table below.
2. Device installation environment: Check weather conditions and whether components are obstructed, etc. It is recommended to provide photos, videos, and other files to assist in analyzing the installation environment.
3. Power grid: Check whether there is a power failure on the power grid, resulting in an abnormal alarm on the power grid side.
4. PV panel: Check whether the PV panel is damaged and whether the installation joints are aged or loose.
5. Battery: Check whether the battery switch is closed and whether the battery power runs out.
6. Electrical cable: Check whether the cables at the joints of each node are aged or damaged.

Table 9-1 Energy Storage Inverter Fault Information

Description	Alarm code	Solutions
Battery Low Voltage	Warn000	1. Check if the battery circuit breaker is closed; 2. Check if the battery connection is normal. 3. If the fault persists, please contact the after-sales service center.
Ex Fan Abn	Warn001	1. Observe for 5 minutes to see if it automatically eliminates; 2. If not, turn off the machine and restart it after 5 minutes; 3. If the fault persists, please contact the after-sales service center.

In Fan Abn	Warn002	<ol style="list-style-type: none"> 1. Observe for 5 minutes to see if it automatically eliminates; 2. If not, turn off the machine and restart it after 5 minutes; 3. If the fault persists, please contact the after-sales service center.
Eeprom Fault	Warn003	<ol style="list-style-type: none"> 1. Observe for 5 minutes to see if it automatically eliminates; 2. If the fault persists, please contact the after-sales service center.
PV Low Voltage	Warn004	<ol style="list-style-type: none"> 1. Observe for 5 minutes to see if it automatically eliminates; 2. If the fault persists, please contact the after-sales service center.
Temp Sensor Abn	Warn005	<ol style="list-style-type: none"> 1. Observe for 5 minutes to see if it automatically eliminates; 2. If not, turn off the machine and restart it after 5 minutes; 3. If the fault persists, please contact the after-sales service center.
DC SPD Abn	Warn006	<ol style="list-style-type: none"> 1. Observe for 5 minutes to see if it automatically eliminates; 2. If not, turn off the machine and restart it after 5 minutes; 3. If the fault persists, please contact the after-sales service center.
AC SPD Abn	Warn007	<ol style="list-style-type: none"> 1. Observe for 5 minutes to see if it automatically eliminates; 2. If not, turn off the machine and restart it after 5 minutes; 3. If the fault persists, please contact the after-sales service center.
DCDC Uneven Current	Warn008	<ol style="list-style-type: none"> 1. Observe for 5 minutes to see if it automatically eliminates; 2. If the fault persists, please contact the after-sales service center.
DCDC Lockdown	Warn009	<ol style="list-style-type: none"> 1. Observe for 5 minutes to see if it automatically eliminates; 2. If not, turn off the machine and restart it after 5 minutes; 3. If the fault persists, please contact the after-sales service center.
Inverse Lockdown	Warn010	<ol style="list-style-type: none"> 1. Observe for 5 minutes to see if it automatically eliminates; 2. If not, turn off the machine and restart it after 5 minutes;

		3. If the fault persists, please contact the after-sales service center.
Grid Inst Overvolt	Warn011	1. Observe for 5 minutes to see if it automatically eliminates; 2. If the fault persists, please contact the after-sales service center.
Grid Phase Vrms Ultralimit	Warn012	1. Observe for 5 minutes to see if it automatically eliminates; 2. If not, turn off the machine and restart it after 5 minutes; 3. If the fault persists, please contact the after-sales service center.
Grid Freq High	Warn013	
Grid Freq Low	Warn014	
Grid Loss	Warn015	1. Check if the AC circuit breaker is closed. 2. Check if the wiring of the power grid side cables is correct. 3. Check whether the quality of the power grid is reliable. 4. If the fault persists, please contact the after-sales service center.
Low battery SOC	Warn100	1. This fault indicates that the battery energy is insufficient currently. If the photovoltaic or power grid is normal, the battery will automatically switch to charging mode, and the fault can be cleared automatically. 2. If the fault persists, please contact the after-sales service center.
MCU Warning	Warn101	1. Observe for 5 minutes to see if it automatically eliminates; 2. If the fault persists, please contact the after-sales service center.
Parallel Address Setting Wrong	Warn102	1. Check if the parallel address is set correctly; 2. If the fault persists, please contact the after-sales service center.
Parallel Parameters Inconsistency	Warn103	1. Check if the parameters of each machine are set consistently; 2. If the fault persists, please contact the after-sales service center.
DCV High	Warn107	1. Observe for 5 minutes to see if it automatically eliminates;

		<ol style="list-style-type: none"> 2. If not, turn off the machine and restart it after 5 minutes; 3. If the fault persists, please contact the after-sales service center.
Battery Disconnect	Warn109	<ol style="list-style-type: none"> 1. Check if the battery circuit breaker is closed; 2. Check if the battery connection is normal. 3. If the fault persists, please contact the after-sales service center.
Passive Island	Warn110	<ol style="list-style-type: none"> 1. Observe for 5 minutes to see if it automatically eliminates; 2. If not, turn off the machine and restart it after 5 minutes; 3. If the fault persists, please contact the after-sales service center.
Grid Voltage Harmonic High	Warn111	<ol style="list-style-type: none"> 1. Observe for 10 minutes to see if it automatically eliminates; 2. If not, turn off the machine and restart it after 5 minutes; 3. If the fault persists, please contact the after-sales service center.
Island Frequency Abn	Warn112	<ol style="list-style-type: none"> 1. Observe for 10 minutes to see if it automatically eliminates; 2. If not, turn off the machine and restart it after 5 minutes; 3. If the fault persists, please contact the after-sales service center.
Grid Voltage Imbalance	Warn113	<ol style="list-style-type: none"> 1. Observe for 10 minutes to see if it automatically eliminates; 2. If not, turn off the machine and restart it after 5 minutes; 3. If the fault persists, please contact the after-sales service center.
Grid Line Voltage Ultralimit	Warn114	<ol style="list-style-type: none"> 1. Observe for 10 minutes to see if it automatically eliminates; 2. If not, turn off the machine and restart it after 5 minutes; 3. If the fault persists, please contact the after-sales service center.
Island	Warn115	<ol style="list-style-type: none"> 1. Observe for 10 minutes to see if it automatically eliminates; 2. If not, turn off the machine and restart it after 5 minutes; 3. If the fault persists, please contact the after-sales service center.
Inv Short-Circuit Protect	Protect000	<ol style="list-style-type: none"> 1. Observe for 5 minutes to see if it automatically eliminates;

		2. Check if the back-up power is too high or short circuited; 3. If the fault persists, please contact the after-sales service center.
Open Loop Check Abn	Protect001	1. Observe for 5 minutes to see if it automatically eliminates; 2. If the fault persists, please contact the after-sales service center.
DCI High	Protect003	1. Observe for 5 minutes to see if it automatically eliminates; 2. Check if the back-up power is too high or short circuited; 3. If the fault persists, please contact the after-sales service center.
No DC Input	Protect005	1. Confirm whether the DC side is connected to PV or battery; 2. Turn off the machine and restart it after 2 minutes; 3. If the fault persists, please contact the after-sales service center.
GFCI Dynamics High	Protect006	1. Observe for 5 minutes to see if it automatically eliminates; 2. If the environment is normal, please check whether the insulation impedance of the photovoltaic string to ground is too low and whether the insulation of the AC cable is good; 3. Turn off the machine if it doesn't eliminate, and restart it after 5 minutes; 4. If the fault persists, please contact the after-sales service center.
GFCI Statics High	Protect007	1. Observe for 5 minutes to see if it automatically eliminates; 2. If the environment is normal, please check whether the insulation impedance of the photovoltaic string to ground is too low and whether the insulation of the AC cable is good; 3. Turn off the machine if it doesn't eliminate, and restart it after 5 minutes; 4. If the fault persists, please contact the after-sales service center.
Inverse Overcurrent	Protect009	1. Observe for 5 minutes to see if it automatically eliminates; 2. If not, turn off the machine and restart it after 5 minutes; 3. If the fault persists, please contact the after-sales service center.

ARC Board Err	Protect010	<ol style="list-style-type: none"> 1. Observe for 5 minutes to see if it automatically eliminates; 2. If not, turn off the machine and restart it after 5 minutes; 3. If the fault persists, please contact the after-sales service center.
ARC Protection	Protect011	<ol style="list-style-type: none"> 1. Check whether the PV wiring and photovoltaic module wiring are loose, whether the contact is good, and observe whether it automatically eliminates after 5 minutes; 2. Turn off the machine and restart it after 5 minutes; 3. If the fault persists, please contact the after-sales service center.
RSD Fault	Protect012	<ol style="list-style-type: none"> 1. Check whether the PV wiring and photovoltaic module wiring are loose, whether the contact is good, and observe whether it automatically eliminates after 5 minutes; 2. Turn off the machine and restart it after 5 minutes; 3. If the fault persists, please contact the after-sales service center.
Grid Relay Abn	Protect013	Please contact the after-sales service center.
INV Relay Abn	Protect014	Please contact the after-sales service center.
AC Side Abn	Protect015	<ol style="list-style-type: none"> 1. Observe for 10 minutes to see if it automatically eliminates; 2. If not, turn off the machine and restart it after 5 minutes; 3. If the fault persists, please contact the after-sales service center.
PV Reverse Polarity	Protect100	<ol style="list-style-type: none"> 1. Check if the polarity of the PV string is correct; 2. Turn off the machine and restart it after 5 minutes; 3. If the fault persists, please contact the after-sales service center.
Grid Voltage Harmonics High	Protect101	<ol style="list-style-type: none"> 1. Observe for 10 minutes to see if it automatically eliminates; 2. If not, turn off the machine and restart it after 5 minutes; 3. If the fault persists, please contact the after-sales service center.

Inv And Grid Voltage Diff	Protect102	<ol style="list-style-type: none"> 1. Observe for 10 minutes to see if it automatically eliminates; 2. If not, turn off the machine and restart it after 5 minutes; 3. If the fault persists, please contact the after-sales service center.
Iso Resistance Low	Protect103	<ol style="list-style-type: none"> 1. Observe for 5 minutes to see if it automatically eliminates; 2. If the environment is normal, please check if the photovoltaic module wiring is good; 3. Turn off the machine if it doesn't eliminate, and restart it after 5 minutes; 4. If the fault persists, please contact the after-sales service center.
GFCI CT Abn	Protect104	<ol style="list-style-type: none"> 1. Turn off the machine, disconnect the PV, battery, and power grid, wait for 5 minutes, reconnect the PV, battery, and power grid, and then turn on the machine; 2. If the fault persists, please contact the after-sales service center.
PV Overvolt	Protect105	<ol style="list-style-type: none"> 1. Check if the configuration of the photovoltaic panel is within the specified range; 2. Turn off the machine if it doesn't eliminate, and restart it after 5 minutes; 3. If the fault persists, please contact the after-sales service center.
Battery Reverse Polarity	Protect107	<ol style="list-style-type: none"> 1. Check if the polarity of the PV string is correct; 2. Turn off the machine if it doesn't eliminate, and restart it after 5 minutes; 3. If the fault persists, please contact the after-sales service center.
Inv HW Overcurr	Protect108	<ol style="list-style-type: none"> 1. Observe for 5 minutes to see if it automatically eliminates; 2. If not, turn off the machine and restart it after 5 minutes; 3. If the fault persists, please contact the after-sales service center.
MiniMcu Comm Abn	Protect109	<ol style="list-style-type: none"> 1. Observe for 5 minutes to see if it automatically eliminates; 2. If not, turn off the machine and restart it after 5 minutes; 3. If the fault persists, please contact the after-sales service center.
Half BUS Imbalance	Protect110	<ol style="list-style-type: none"> 1. Observe for 5 minutes to see if it automatically eliminates;

		2. If not, turn off the machine and restart it after 5 minutes; 3. If the fault persists, please contact the after-sales service center.
DCDC Softstart Circuit Abn	Protect111	1. Observe for 5 minutes to see if it automatically eliminates; 2. If not, turn off the machine and restart it after 5 minutes; 3. If the fault persists, please contact the after-sales service center.
DCDC Hardware Overcurrent	Protect112	1. Observe for 5 minutes to see if it automatically eliminates; 2. If not, turn off the machine and restart it after 5 minutes; 3. If the fault persists, please contact the after-sales service center.
Interior Hardware Fault	Protect113	1. Observe for 5 minutes to see if it automatically eliminates; 2. If not, turn off the machine and restart it after 5 minutes; 3. If the fault persists, please contact the after-sales service center.
Bus HW Overvolt	Protect114	1. Observe for 5 minutes to see if it automatically eliminates; 2. If not, turn off the machine and restart it after 5 minutes; 3. If the fault persists, please contact the after-sales service center.
Interior CAN Comm Abn	Protect115	1. Observe for 5 minutes to see if it automatically eliminates; 2. If not, turn off the machine and restart it after 5 minutes; 3. If the fault persists, please contact the after-sales service center.
Temperature Sensor And Fan Module Abn	Protect200	1. Observe for 5 minutes to see if it automatically eliminates; 2. If not, turn off the machine and restart it after 5 minutes; 3. If the fault persists, please contact the after-sales service center.
Pure PV Mode Configured Fault	Protect201	1. Check if the Pure PV Mode configuration is correct 2. Restart and observe if the error is automatically eliminated 3. If the fault persists, please contact the after-sales service center.

Battery Overvolt	Protect202	<p>. Check if the battery voltage exceeds the specifications;</p> <p>2. Observe for 5 minutes to see if it automatically eliminates;</p> <p>3. If not, turn off the machine and restart it after 5 minutes;</p> <p>4. If the fault persists, please contact the after-sales service center.</p>
Half BUS Overvolt	Protect203	<p>1. Observe for 5 minutes to see if it automatically eliminates;</p> <p>2. If not, turn off the machine and restart it after 5 minutes;</p> <p>3. If the fault persists, please contact the after-sales service center.</p>
PV Overcurr	Protect204	<p>1. Observe for 5 minutes to see if it automatically eliminates;</p> <p>2. If not, turn off the machine and restart it after 5 minutes;</p> <p>3. If the fault persists, please contact the after-sales service center.</p>
BUS Overvolt	Protect205	<p>1. Observe for 5 minutes to see if it automatically eliminates;</p> <p>2. If not, turn off the machine and restart it after 5 minutes;</p> <p>3. If the fault persists, please contact the after-sales service center.</p>
Low Speed Synchronization	Protect206	<p>1. Observe for 5 minutes to see if it automatically eliminates;</p> <p>2. If not, turn off the machine and restart it after 5 minutes;</p> <p>3. If the fault persists, please contact the after-sales service center.</p>
Off-grid And On-grid Para Diff	Protect207	<p>1. Observe for 5 minutes to see if it automatically eliminates;</p> <p>2. If not, turn off the machine and restart it after 5 minutes;</p> <p>3. If the fault persists, please contact the after-sales service center.</p>
Type Error	Protect208	<p>1. Observe for 5 minutes to see if it automatically eliminates;</p> <p>2. If not, turn off the machine and restart it after 5 minutes;</p> <p>3. If the fault persists, please contact the after-sales service center.</p>
Balance Bridge Curr	Protect209	<p>1. Turn off the machine, disconnect the PV, battery, and power grid, wait for 5 minutes,</p>

Sampling Offset Abn		reconnect the PV, battery, and power grid, and then turn on the machine; 2. If the fault persists, please contact the after-sales service center.
PV hardware Overcurr	Protect210	1. Observe for 5 minutes to see if it automatically eliminates; 2. If not, turn off the machine and restart it after 5 minutes; 3. If the fault persists, please contact the after-sales service center.
PV Curr Sampling Offset Abn	Protect211	1. Turn off the machine, disconnect the PV, battery, and power grid, wait for 5 minutes, reconnect the PV, battery, and power grid, and then turn on the machine; 2. If the fault persists, please contact the after-sales service center.
DCI Sampling Offset Abn	Protect212	1. Turn off the machine, disconnect the PV, battery, and power grid, wait for 5 minutes, reconnect the PV, battery, and power grid, and then turn on the machine; 2. If the fault persists, please contact the after-sales service center.
DCDC Overcurr	Protect213	1. Observe for 5 minutes to see if it automatically eliminates; 2. If not, turn off the machine and restart it after 5 minutes; 3. If the fault persists, please contact the after-sales service center.
Inv Curr Sampling Offset Abn	Protect214	1. Turn off the machine, disconnect the PV, battery, and power grid, wait for 5 minutes, reconnect the PV, battery, and power grid, and then turn on the machine; 2. If the fault persists, please contact the after-sales service center.
Overtemperat ure	Protect215	1. Observe for 5 minutes to see if it automatically eliminates; 2. If not, turn off the machine and restart it after 5 minutes; 3. If the fault persists, please contact the after-sales service center.
MPPT Curr Sampling Offset Abn	Protect300	1. Turn off the machine, disconnect the PV, battery, and power grid, wait for 5 minutes, reconnect the PV, battery, and power grid, and then turn on the machine; 2. If the fault persists, please contact the after-sales service center.

VSload PF Undervalue	Protect301	<ol style="list-style-type: none"> 1. Check if the PF (power factor) is too small when loads are supplied power in off-grid condition; 2. If the fault persists, please contact the after-sales service center.
DCDC Curr Sampling Offset Abn	Protect302	<ol style="list-style-type: none"> 1. Turn off the machine, disconnect the PV, battery, and power grid, wait for 5 minutes, reconnect the PV, battery, and power grid, and then turn on the machine; 2. If the fault persists, please contact the after-sales service center.
GFCI Curr Sampling Offset Abn	Protect303	<ol style="list-style-type: none"> 1. Turn off the machine, disconnect the PV, battery, and power grid, wait for 5 minutes, reconnect the PV, battery, and power grid, and then turn on the machine; 2. If the fault persists, please contact the after-sales service center.
Load Curr Sampling Offset Abn	Protect304	<ol style="list-style-type: none"> 1. Turn off the machine, disconnect the PV, battery, and power grid, wait for 5 minutes, reconnect the PV, battery, and power grid, and then turn on the machine; 2. If the fault persists, please contact the after-sales service center.
CPLD Clock Abn	Protect305	<ol style="list-style-type: none"> 1. Turn off the machine, disconnect the PV, battery, and power grid, wait for 5 minutes, reconnect the PV, battery, and power grid, and then turn on the machine; 2. If the fault persists, please contact the after-sales service center.
Parallel CAN Comm Abn	Protect306	<ol style="list-style-type: none"> 1. Check if the network cable connection for parallel communication is correct; 2. Check if the parallel dialing switch is turned to the correct position; 3. If the fault persists, please contact the after-sales service center.
Backup Port Voltage Abn	Protect307	<ol style="list-style-type: none"> 1. Check if the connection between the backup port and the grid port is connected correctly 2. Observe for 5 minutes to see if it automatically eliminates; 3. Turn off the machine if it doesn't eliminate, and restart it after 5 minutes; 4. If the fault persists, please contact the after-sales service center.

Backup Port overload	Protect308	<ol style="list-style-type: none"> 1. Check if the connection between the backup port and the grid port is connected correctly 2. Observe for 5 minutes to see if it automatically eliminates; 3. Turn off the machine if it doesn't eliminate, and restart it after 5 minutes; 4. If the fault persists, please contact the after-sales service center.
Network Port overload	Protect309	<ol style="list-style-type: none"> 1. Check if the connection between the backup port and the grid port is connected correctly 2. Observe for 5 minutes to see if it automatically eliminates; 3. Turn off the machine if it doesn't eliminate, and restart it after 5 minutes; 4. If the fault persists, please contact the after-sales service center.
N To Ground Volt Ultralimit	Protect310	<ol style="list-style-type: none"> 1. Observe for 5 minutes to see if it automatically eliminates; 2. Turn off the machine if it doesn't eliminate, and restart it after 5 minutes; 3. If the fault persists, please contact the after-sales service center.
DCV Volt Sampling Offset Abn	Protect311	<ol style="list-style-type: none"> 1. Turn off the machine, disconnect the PV, battery, and power grid, wait for 5 minutes, reconnect the PV, battery, and power grid, and then turn on the machine; 2. If the fault persists, please contact the after-sales service center.
AC Soft-start Circuit Abn	Protect313	<ol style="list-style-type: none"> 1. Turn off the machine, disconnect the PV, battery, and power grid, wait for 5 minutes, reconnect the PV, battery, and power grid, and then turn on the machine; 2. If the fault persists, please contact the after-sales service center.
Balance Bridge Hardware Overcurr	Protect314	<ol style="list-style-type: none"> 1. Observe for 5 minutes to see if it automatically eliminates; 2. Turn off the machine if it doesn't eliminate, and restart it after 5 minutes; 3. If the fault persists, please contact the after-sales service center.
BUS voltage is less than battery voltage	Protect315	<ol style="list-style-type: none"> 1. Observe for 5 minutes to see if it automatically eliminates; 2. Turn off the machine if it doesn't eliminate, and restart it after 5 minutes; 3. If the fault persists, please contact the after-sales service center.

Inv And Grid Voltage Diff Fault	Fault001	please contact the after-sales service center.
Inv Grid Relay Fault	Fault003	please contact the after-sales service center.
Inv Relay Fault	Fault004	please contact the after-sales service center.
Inv Overcurrent Fault	Fault009	please contact the after-sales service center.
Inv Self-check Fault	Fault012	please contact the after-sales service center.
Inv Short Circuit Fault	Fault015	please contact the after-sales service center.
Grid Meter Comm Failure	Warn2000	<ol style="list-style-type: none"> 1. Check if the grid side electricity meter connection is normal; 2. Check if there is grid voltage; 3. If the fault persists, please contact the after-sales service center.
AC solar Meter Comm Failure	Warn2010	<ol style="list-style-type: none"> 1. Check if the connection of the AC side photovoltaic meter is normal; 2. Check if there is grid voltage; 3. If the fault persists, please contact the after-sales service center.
Timing Exception	Warn2020	<ol style="list-style-type: none"> 1. Remove the WIFI/4G stick, reinsert it, and observe for 5 minutes whether it automatically eliminates; 2. Turn off the machine if it doesn't eliminate, and restart it after 5 minutes; 3. If the fault persists, please contact the after-sales service center.
DSP Comm Abn	Warn2040	<ol style="list-style-type: none"> 1. Observe for 5 minutes to see if it automatically eliminates; 2. Turn off the machine if it doesn't eliminate, and restart it after 5 minutes; 3. If the fault persists, please contact the after-sales service center.
BMS Comm Abn	Warn2050	<ol style="list-style-type: none"> 1. Check if the network cable connection for BMS communication is normal; 2. Check if the battery is turned on; 3. If the fault persists, please contact the after-sales service center.

9.2 Fault Maintenance

9.2.1 Inverter Power-off

WARNING:

Stop the inverter before product maintenance. Disconnect the AC circuit breaker connected to the power grid, cut off the PV input connection on the DC side, and wait for at least 5 minutes before starting operation.

The power off steps are as follows:

1. Turn off ON-GRID circuit breaker.
2. Turn off BACK-UP circuit breaker.
3. Turn off PV switch.
4. Turn off BAT circuit breaker.
5. Turn on/off BAT circuit breaker.

9.2.2 Inverter Removal

DANGER:

- Ensure that the inverter is de-energized.
- Wear personal protective equipment when operating the inverter.

-
1. Disconnect all electrical connections of the inverter, including DC cable, AC cable, communication cable, communication module, and protective earth cable.
 2. Remove the inverter from the back bracket.
 3. Remove the back bracket.
 4. Properly store the inverter. If the inverter needs to be put into use in the future, ensure that the storage conditions meet the requirements.

9.3 Routine Maintenance

WARNING:

Before maintenance, turn off the inverter, disconnect the AC breaker to disconnect the inverter from power grid, disconnect the PV and battery input of the DC side.

Wait at least 5 minutes to continue maintenance.

Inverters usually do not require maintenance or calibration, but in order to ensure the long-term good operation of the energy storage system, it is recommended to perform routine maintenance according to this chapter.

- Inverter cleaning:
 1. Clean the inverter with an electric compressed air blower, a dry soft cloth or a soft brush.
 2. Do not use water, corrosive chemicals, cleaning agents or strong detergents to clean the inverter.
- Cooling fin cleaning:
 1. Ensure that there is enough airflow space around the radiator at the rear of the inverter and there shall be no substances that hinder airflow around the cooling fin, such as dust or snow which must be removed, to ensure the normal function and long-term service life of the inverter.
 2. Clean the cooling fins with compressed air, soft cloth or soft brush.
 3. Do not use water, corrosive chemicals, cleaning agents or strong detergents to clean the cooling fin.
- System cleaning:
 1. Regularly check whether the energy storage system is blocked or stained.
 2. Do it every six months to one year.

- System operation state indicator:
 1. Observe whether the appearance of energy storage is damaged or deformed. Listen for any abnormal sounds during the energy storage. During energy storage, check whether energy storage parameters are set correctly.
 2. Do it every six months.
- Electrical connection:
 1. Check whether the cable connection is disengaged or loose, whether the cable is damaged, and especially whether there are any cut marks on the surface of the cable in contact with the metal surface. Check whether unused DC input terminals, energy storage terminals, COM ports, and waterproof covers are locked.
 2. Check it every six months to one year after the initial commissioning.
- Earthing reliability:
 1. Check whether the earth cable is reliably earthed.
 2. Check it every six months to one year after the initial commissioning.

10. Technical Data

Model	ECH8K-TH-EU	ECH10K-TH-EU	ECH12K-TH-EU	ECH15K-TH-EU	ECH18K-TH-EU	ECH20K-TH-EU
Efficiency						
Max. Efficiency (PV to Grid)	98.20%	98.30%	98.30%	98.30%	98.30%	98.30%
Eur. Efficiency (PV to Grid)	97.50%	97.60%	97.70%	97.70%	97.70%	97.70%
Max. Efficiency (Battery to Load)	97.50%	97.50%	97.80%	97.80%	97.80%	97.80%
PV						
Rated Input Voltage	600V	600V	600V	600V	600V	600V
Max. Input Voltage	1100V	1100V	1100V	1100V	1100V	1100V
Max. Input Power	12.80kW	16.00kW	19.20kW	24.00kW	28.80kW	30.00kW
Max. Input Current per MPPT	16A/16A/16A/16A	16A/16A/16A/16A	16A/16A/16A/16A	16A/16A/16A/16A	16A/16A/16A/16A	16A/16A/16A/16A
Max. Short Circuit Current per MPPT	24A/24A/24A/24A	24A/24A/24A/24A	24A/24A/24A/24A	24A/24A/24A/24A	24A/24A/24A/24A	24A/24A/24A/24A
No. of MPPTs	4	4	4	4	4	4
No. of Strings per MPPT	1	1	1	1	1	1
Start Input Voltage	160V	160V	160V	160V	160V	160V
PV Operating Voltage Range	160-1000V	160-1000V	160-1000V	160-1000V	160-1000V	160-1000V
Battery						
Battery Type	Lithium-ion/Lead-Acid					
Battery Voltage Range	160-600V	160-600V	160-600V	160-600V	160-600V	160-600V
Max. Charge/Discharge Current	50A/50A	50A/50A	50A/50A	50A/50A	50A/50A	50A/50A

Max. Charge/Discharge Power	20kW/8kW	20kW/10kW	20kW/12kW	20kW/15kW	20kW/18kW	20kW/20kW
Grid						
Max. Input Current	60.8A	60.8A	60.8A	60.8A	60.8A	60.8A
Rated Output Apparent Power	8.0kVA	10.0kVA	12.0kVA	15.0kVA	18.0kVA	20.0kVA
Max. Output Apparent Power	8.8kVA	11.0kVA	13.2kVA	16.5kVA	19.8kVA	20.0kVA
Rated Output Voltage	3W / N / PE; 220 / 380 3W / N / PE; 230 / 400 3W / N / PE; 240 / 415 adjustable					
Rated Grid Frequency	50Hz/60Hz					
THDI	<2% (Rated Power)					
Power Factor	> 0.99 Rated power (Adjustable 0.8 Leading - 0.8Lagging)					
Power system	TT, TN					
Inrush current	25.5A@15us					
Backup Port						
Max. Output Current (On Grid)	60.8A	60.8A	60.8A	60.8A	60.8A	60.8A
Max. Output Apparent Power (On Grid)	40.0kVA	40.0kVA	40.0kVA	40.0kVA	40.0kVA	40.0kVA
Max. Output Apparent Power (Off Grid)	8.8kVA	11.0kVA	13.2 kVA	16.5kVA	19.8kVA	22.0kVA
Peak Output Apparent Power	22 @60s	22 @60s	22 @60s	22 @60s	22 @60s	22 @60s
Rated Output Voltage	380V/400V/415V, 3W+N+PE					
Rated Output Frequency	50Hz/60Hz					
Max. Output Single Phase Apparent Power	4.0kVA	5.0kVA	6.0kVAz	7.5kVAz	9.0kVA	9.0kVA
THDV	<2% @100% R Load					

Switching Time	10ms	10ms	10ms	10ms	10ms	10ms
Protection						
DC Switch						Support
Anti-islanding Protection						Support
AC Overcurrent Protection						Support
AC Short Circuit Protection						Support
PV String Reverse Protection						Support
Surge Arrester						AC Type II, DC Type II
AFCI						Support
RSD Function						Optional
General						
Topology						Non-Isolated
IP Rating						IP66
Cooling						Forced airflow
Operating Temperature Range						-25°C-60°C
Relative Humidity Range						0-100%
Max. Operating Altitude						4000m
Noise (Typical)						<45dB
Dimensions (W*H*D)						≈617/598/291.7mm
Weight						≈41kg
Display						LED&APP
Communication						RS485, CAN, WIFI/4G (optional)

Certification

Safety	IEC62109-1&2 IEC61000
Grid Code	EN50549, VDE4105, Tor erzeuger typeA+R25 Tor erzeuger type B, EIFS2018-2, CEI 021, NC RfG, PTPIREE, PSE S.A., EN50549-1

* The certificates are for reference only. Please consult the local sales staff for detailed cortication.

11. Quality Assurance

11.1 Liability exemption

1. Exceed the quality assurance period of the product.
2. Cannot provide product serial number or the SN is not clear/complete.
3. Damage during transportation/storage/handling/use.
4. Misuse, abuse, intentional damage, negligence or accidental damage.
5. Improper testing, operation, maintenance or installation performed by customer, including but not limited to:
 - Failure to meet safe operating environment or system requirements of external electrical parameters provided in written document;
 - Failure to operate the covered product in accordance with the product's operating manual or user guide;
 - Relocate and reinstall systems not in accordance with the requirements of CPS;
 - Unsafe electrical or chemical environment or other similar kind of conditions;
 - Direct failure caused by wrong voltage or faulty power system;
 - Unauthorized disassembly of the products, or unauthorized modification of the product or provided software;
 - Entrust maintenance personnel not designated by the CPS to repair and disassemble the products;
6. Damages caused by ignoring the safety warnings in the manual or break the rules in relevant statutory safety regulations;
7. Damages caused by operating environment beyond the requirements of the product user manual or failure to install, use and maintain the equipment according to the requirements of the product user manual.
8. Unforeseen disasters or irresistible accidents (including but not limited to acts of public enemies, acts of government agencies or domestic or foreign institutions, vandalism, riots, fires, floods, typhoons, explosions or other disasters, epidemic or quarantine restrictions, labor disturbances or labor

shortages, accidents, cargo embargoes or any other events beyond the control of CPS).

9. The lightning protection measures have not been implemented or are not in accordance with standards (Photovoltaic systems' lightning protection measures should comply with the relevant national and IEC standards; otherwise, it may result in damage to photovoltaic devices such as modules, inverters, distribution facilities, etc., due to lightning strikes).

10. Other circumstances that are not covered by the company's after-sales warranty agreement.

11. Equipment failure or software damage caused by using non-standard components/accessories, connection of incompatible configurations (such as batteries, etc.) or other brand products or accessories without permission, improper configuration selection/storage/use.

11.2 Warranty Clauses

1. For products that fail during the warranty period, CPS will repair or replace new products free of charge;
2. Customer shall present the invoice of the product and date of purchase. At the same time, the trademark on the product should be clearly visible, otherwise we have rights to refuse quality assurance.
3. The unqualified product under replacement should be returned to our company;
4. It is necessary to provide a reasonable time for the company to overhaul the equipment.
5. For more warranty terms, refer to the applicable standard warranty policy in place at time of purchase

If you have any questions, please contact us, we will be very happy to help you.

12. Recycling

Distributors or installers should contact the inverter manufacturer after removing the inverter from the photovoltaic module and follow the instructions.



The inverter cannot be disposed of as household waste.

When the inverter's service life expires, please dispose of it in accordance with the electrical waste disposal laws applicable to the installation location.

You can contact the inverter manufacturer or distributor for handling

Shanghai Chint Power Systems Co., Ltd.

Headquarters: No. 5999, Guangfulin Road, Songjiang District, 201616

Shanghai, P R. China

Switchboard: +86-21-37791222

Fax: +86-21-37791222-866003

Website: www.chintpower.com

Service hotline: +86-21-37791222-866300

E-mail: service.cps@chint.com

The above information is subject to change without prior notice.

Any unauthorized copying and plagiarism are prohibited.