

CPS ES-125kW/261kWh-EU

Liquid-cooled Commercial and Industrial Integrated Cabinet

User Manual



Shanghai CHINT Power Systems Co., Ltd.

Revision history

Rev.	Date	Content
V 1.0	Apr. 2025	First Edition
V 1.1	Jul.2025	Add important notes in 2.3 Safety Requirements for the Owner
V 1.2	Sept.2025	Update cutout dimensions to table 3-2 Cutout function Add picture of dimensions of AC cable compressing lug Update figure Annex 6-1
V 2.0	Apr.2026	Reorganize the document structure
V 2.1	Jun.2026	Add section 9.6.2 Replacement

Legal Notice

Copyright © Shanghai Chint Power Systems Co., Ltd. 2026. All rights reserved.

No part of this document may be reproduced, disseminated, or uploaded to any network or platform in any form without prior written permission from Shanghai Chint Power Systems Co., Ltd. (hereinafter referred to as "Chint Power").

Trademark



This trademark and other Chint power trademarks used in this manual are owned by Chint Power. All other trademarks or registered trademarks mentioned in this Manual are the property of their respective owners. Nothing contained in this manual should be construed as granting any license or right to use. Any trademark can not be used without the prior written permission of our company or the respective third party.

Disclaimer

- While every effort has been made to ensure the accuracy and completeness of this manual, the information contained herein is for guidance only. Chint Power shall not be liable for any errors or omissions, nor for any consequences arising from the use of this information.
- **Non-Warranty Statement:** All statements, information, and recommendations in this manual are for guidance only and do not constitute any form of express or implied warranty.
- Due to continuous product development, Chint Power reserves the right to update the contents of this manual at any time without prior notice. Please obtain the latest version through our official channels to ensure safe and optimal equipment operation.

Table of Contents

About This Manual	1
1. Safety Information	3
1.1. Safety and Compliance Overview	3
1.2. Personnel Safety and Qualifications	3
1.2.1. Personnel Requirements.....	4
1.2.2. Authorized Access & Site Control.....	5
1.2.3. Mandatory PPE.....	5
1.3. Electrical Safety Principles.....	6
1.3.1. Basic Electrical Requirements.....	6
1.3.2. De-energization and Discharge Protocol	7
1.3.3. Grounding Standards	7
1.3.4. Cabling and Connection Requirements	7
1.3.5. Ingress and Contamination Protection.....	7
1.3.6. External Electrical Risk Protection.....	7
1.4. Environment and Site Safety.....	8
1.4.1. Prohibited Installation Environments	8
1.4.2. Site Infrastructure & Structural Requirements	9
1.4.3. Vegetation & Site Cleanliness	9
1.4.4. Fire emergency Protocols	9
1.5. Mechanical Safety.....	10
1.5.1. Tool and Structural Integrity	10
1.5.2. Handling and Hoisting Safety	10
1.5.3. Elevated Work Standards.....	10
1.5.4. Drilling Prohibition	10
1.6. Labels On the Equipment.....	11
1.7. Lockout/Tagout Guidance	12
2. System Introduction.....	13

2.1.	Model Description	14
2.2.	Dimensions and Appearance	15
2.3.	Parameters	17
2.4.	Nameplate	18
2.5.	System Annotation.....	19
2.6.	Battery System	20
2.6.1.	Battery Pack.....	21
2.6.2.	Battery Management System (BMS)	22
2.6.3.	High Voltage Box	24
2.7.	Power Conversion System (PCS)	28
2.8.	Local Energy Management System (LEMS).....	30
2.8.1.	LEMS Control System Diagram.....	31
2.8.2.	System Functions.....	31
2.8.3.	Communication Connection Requirements	32
2.9.	Power Distribution System	33
2.10.	Thermal Management System	34
2.11.	Fire Safety System.....	37
2.12.	Architecture Diagram	39
2.12.1.	Electrical Architecture Diagram	39
2.12.2.	Communication Architecture Diagram	40
3.	Transportation and Storage	41
3.1.	Transportation.....	41
3.1.1.	Transportation Requirements	41
3.1.2.	Crane Lifting.....	44
3.1.3.	Forklift Handling	46
3.2.	Storage	47
3.2.1.	System Storage Requirements.....	47
3.2.2.	Battery Storage Requirement	48

3.2.3. Periodic Maintenance and Activation.....	48
4. Installation.....	49
4.1. Installation Requirements.....	49
4.1.1. Site Selection Requirements.....	49
4.1.2. Clearance Requirements.....	50
4.1.3. Foundation Requirements.....	52
4.2. System Unpacking Inspection.....	54
4.2.1. Precautions.....	54
4.2.2. Scope of Delivery.....	55
4.2.3. Safety Inspection.....	56
4.3. ESS Installation.....	57
5. Cable Connection.....	62
5.1. Cable Specifications.....	62
5.2. Grounding Connection.....	63
5.3. AC Cable Connection.....	65
5.4. Communication Connection.....	68
5.5. Apply Fireproof Putty.....	72
5.6. MSD Installation.....	73
6. Emergency Handling Procedure.....	74
6.1. Emergency Stop.....	74
6.2. Leakage of Electrolyte.....	76
6.3. Fire.....	77
6.3.1. Classification of Fire Hazards.....	77
6.3.2. Fire Risk Deduction.....	77
6.3.3. Identify Fire Hazards.....	80
6.3.4. Measures When There is Fire.....	80
6.4. Flood and Water Disaster.....	81
7. Operation Procedure.....	82

7.1.	Power-on Procedure	82
7.1.1.	Pre-power-on Inspection	82
7.1.2.	Power-on Operation Procedures	85
7.1.3.	Inspection after Power-on	86
7.2.	BMS Operation Procedures	88
7.3.	PCS Operation Procedures.....	93
7.4.	LEMS Operation Procedures	93
7.5.	Parameter Setting.....	93
7.5.1.	BMS Parameter Settings.....	93
7.5.2.	PCS Parameter Settings	96
7.5.3.	LEMS Parameter Settings.....	97
7.5.4.	Liquid Cooling Unit Parameter Settings.....	97
7.5.5.	Dehumidification Parameter Settings	98
7.5.6.	Auxiliary Meter Parameter Settings	98
7.5.7.	I/O module Parameter Settings	98
7.6.	Power-off Procedure	99
8.	Troubleshooting	101
8.1.	Alarms and Handling.....	101
8.1.1.	LEMS Alarm Information	101
8.1.2.	BMS Alarm Information	104
8.2.	BMS Troubleshooting	108
8.3.	Liquid Cooling Unit Troubleshooting	110
8.4.	PCS Troubleshooting.....	113
8.5.	Fire Product Troubleshooting.....	126
8.6.	Dehumidifier Troubleshooting	126
8.7.	UPS Troubleshooting.....	127
9.	Maintenance and Replacement.....	128
9.1.	Battery Maintenance	128

9.1.1. Battery Recharging	128
9.1.2. Maintenance procedure.....	129
9.1.3. Replacement.....	132
9.2. Liquid Cooling Unit Maintenance.....	139
9.2.1. Replacement.....	139
9.2.2. Liquid Replenishment After Equipment Replacement.....	141
9.2.3. Normal Liquid Replenishment	146
9.3. Fire Safety System Maintenance	147
9.3.1. Maintenance Procedure	147
9.3.2. Component Replacement.....	150
9.4. PCS Maintenance	154
9.4.1. Maintenance Procedure	155
9.4.2. Replacement.....	158
9.5. Dehumidifier Maintenance Procedure	160
9.6. Power Distribution Box Maintenance	161
9.7. High Voltage Box Replacement	161
9.8. Cooling Fan Maintenance	164
9.8.1. Maintenance Procedure	164
9.8.2. Cooling Fan Replacement.....	164
9.9. UPS Maintenance	167
9.9.1. Maintenance Procedure	167
9.9.2. Replacement.....	167
9.10. Circuit Breaker Maintenance Procedure.....	169
9.10.1. Circuit Breaker Maintenance	169
9.10.2. Miniature Circuit Breaker Replacement	169
9.10.3. Molded Case Circuit Breaker Replacement.....	171
9.11. Cabinet Maintenance	173
10. Quality Assurance	174

10.1. Liability Exemption	174
10.2. Quality Clause (Warranty Clause).....	175
11. Disposal	176
Annex.....	177
Annex 1 Personal Protective Equipment List	177
Annex 2 List of Tools	178
Annex 3 Suggestions on Anti-corrosion Grades.....	180
Annex 4 Terms and Definitions	181

About This Manual

Document Purpose and Scope

This manual is intended to provide users with comprehensive technical guidance during the processes of transportation, storage, installation, commissioning, and routine maintenance.



IMPORTANT!

- Please hand over this manual to a designated person for safekeeping.
- Before performing any operations, please read this manual carefully and ensure that you fully understand all the contents.

Main content

This manual includes instructions on how to operate the equipment (such as how to debug and properly shut down the equipment), the maintenance plan for the equipment, and considerations for the handling and recycling of system hardware. Therefore, before using this system, please be sure to read this manual carefully and operate the equipment according to the methods described in this manual, otherwise it may cause equipment damage or personal injury.

The abbreviations and related terms mentioned in this manual can be fully understood by referring to the "Terms and Definitions" section in annex 4.

Target audience





This manual is suitable for:

- Owner
- After-sales service engineer
- Installation engineer
- Operation and maintenance engineer

Symbol introduction

The symbols in this document are defined as follows:

Symbols	Meanings
	<p>DANGER!</p> <p>DANGER indicates a hazardous situation with high level of risk which, if not avoided, will result in death or serious injury.</p>

	<p>WARNING!</p> <p>WARNING indicates a hazardous situation with medium level of risk which, if not avoided, could result in death or serious injury.</p>
	<p>CAUTION!</p> <p>CAUTION indicates a hazardous situation with low level of risk which, if not avoided, could result in minor or moderate injury.</p>
	<p>NOTICE!</p> <p>NOTICE indicates a hazardous situation which, if not avoided, could result in equipment working abnormally or property loss.</p>
	<p>IMPORTANT!</p> <p>INSTRUCTION indicates important supplementary information or provides skills or tips that can be used to help you solve a problem or save your time.</p>

Important information

- **Operational Compliance:** Read this manual carefully before use, follow the instructions strictly, and observe all safety precautions on product labels and within this manual.
- **Applicability of Laws and Standards:** In addition to the safety instructions in this manual, you must comply with relevant international, national, or regional laws, regulations, standards, and industry requirements.
- **Limitation of Liability:** The Company shall not be liable for any personal injury, death, or property loss resulting from improper equipment use or violation of safety requirements.

Version upgrade

Due to product updates and improvements, the manual content will be updated, adjusted, and revised accordingly. Please refer to the actual product for the product you purchased. You can obtain the latest version of the manual materials through the corresponding sales channels, or you can log in to our official website to download the latest version of the operation and maintenance manual.

1. Safety Information

	<p>IMPORTANT!</p> <ul style="list-style-type: none"> • Please read this user manual carefully before the installation and operation of this equipment. Chint reserves the right to refuse warranty claims for equipment damage if users fail to install the equipment according to the instructions in this manual. • Failure to follow these instructions and other relevant safety procedures may result in voiding of the warranty and/or damage to the inverter or other property!
---	---

1.1. Safety and Compliance Overview

Operational compliance:

Read this manual carefully before use, follow the instructions strictly, and observe all safety precautions on product labels and within this manual.



Applicability of laws and standards:

In addition to the safety instructions in this manual, you must comply with relevant international, national, or regional laws, regulations, standards, and industry requirements.

Limitation of liability:

The Company shall not be liable for any personal injury, death, or property loss resulting from improper equipment use or violation of safety requirements.

1.2. Personnel Safety and Qualifications

	<p>IMPORTANT!</p> <p>Only qualified professionals are allowed to install, operate or maintain equipment.</p>
	<p>DANGER!</p> <ul style="list-style-type: none"> • Ensure that power is off during installation. Do not install or remove a cable with power on. Transient contact between the core of the cable and the conductor will cause electric arcs, sparks, fire, or explosion, which may result in personal injury. • Non-standard and improper operations on the energized equipment may cause fire, electric shocks, or explosion, resulting in property damage, personal injury, or even death. • Before operations, remove conductive objects such as watches, bracelets, bangles, rings, and necklaces to prevent electric shocks.

**DANGER!**

- During operations, use dedicated insulated tools to prevent electric shocks or short circuits. The dielectric withstanding voltage level must comply with local laws, regulations, standards, and specifications.
- During the normal operation of the liquid-cooled battery system, opening battery compartment doors is not allowed. To open them, wait until the system operation is completed before performing operations and maintenance.

**CAUTION!**

- During operations, wear personal protective equipment such as protective clothing, insulated shoes, goggles, safety helmets, and insulated gloves.
- Before installing equipment in a cabinet, ensure that the cabinet is securely fastened with a balanced center of gravity. Otherwise, tipping or falling cabinets may cause bodily injury and equipment damage.
- When working at heights, wear a safety helmet and safety harness or waist belt and fasten it to a solid structure. Do not mount it on an insecure moveable object or metal object with sharp edges. Make sure that the hooks will not slide off.

1.2.1. Personnel Requirements

- Personnel operating the equipment should be thoroughly familiar with this manual.
- Personnel operating the equipment should be thoroughly familiar with the working principles of the equipment.
- Personnel operating the equipment should be thoroughly familiar with local electrical regulations and standards.
- Only qualified personnel who hold valid electrical knowledge certificates or qualifications, comply with regulatory requirements and safety standards, and have extensive experience in this type of work can operate on circuits and equipment.
- Only qualified personnel familiar with battery PACK and safety precautions can perform the installation and operation of battery PACK. Do not allow unauthorized personnel to access the battery PACK.
- Personnel operating the equipment must be trained and qualified electrical workers. otherwise, they cannot operate the equipment. Improper or incorrect operation may cause serious harm to the operator.
- Transportation, installation, and commissioning can only be performed by professionals designated by the manufacturer.

1.2.2. Authorized Access & Site Control



- **Only authorized professionals** may remove safety barriers, open enclosures, or access internal components. Strictly prohibit unauthorized personnel, untrained individuals, and children from entering the equipment area.
- Personnel performing live-line work, work at heights, or operating specialized hoisting machinery must hold specific task-based certifications required by the local jurisdiction.
- Operating the equipment while under the influence of alcohol, drugs, or in a state of extreme fatigue is strictly prohibited.

1.2.3. Mandatory PPE

Mandatory PPE complying with local statutory standards must be worn throughout on-site operations:

- Eye protection
Safety goggles or face shield to shield against sparks, debris, or accidental electrical contact.
- Hand protection
Insulated gloves rated for the circuit voltage, plus work gloves to prevent abrasion. Insulated gloves rated for circuit voltage. work gloves for mechanical protection against cuts.
- Foot protection
Insulated safety shoes to prevent electric shock or ground current paths.
- Head protection
Hard hat to protect against overhead hazards and falling objects.
- Body protection
Protective clothing or work suit to minimize skin exposure.

1.3. Electrical Safety Principles

	<p>DANGER!</p> <ul style="list-style-type: none"> • No flammable or explosive items should be stored inside or near the equipment. • High-voltage energy remains in capacitors. Failure to wait for the full discharge duration may cause electric shock, severe injury, or death.
	<p>CAUTION!</p> <ul style="list-style-type: none"> • Regularly inspect the safety equipment within the system to ensure that the safety equipment is reliable. • Regularly inspect the safety equipment within the system to ensure that the safety equipment is reliable. • Before installing and commissioning batteries, prepare fire fighting facilities, such as fire sand and carbon dioxide fire extinguishers, according to construction standards and regulations. Before putting into operation, ensure that fire fighting facilities that comply with local laws and regulations are installed.
	<p>NOTICE!</p> <p>The static electricity generated by human bodies may damage the electrostaticsensitive components on boards,</p> <ul style="list-style-type: none"> • Please wear anti-static gloves before touching electronic components.

1.3.1. Basic Electrical Requirements

To prevent electric shock or arc flash injuries, all on-site operations must adhere to the following behavioral standards:

- Eliminate conductive paths by removing all metallic jewelry—including watches, rings, and necklaces—prior to accessing electrical connections.
- Prohibit direct contact with any power terminal or conductor surface until zero voltage is verified via testing.
- Only use certified insulated tools with voltage ratings that align with the specific equipment requirements.
- Never operate power equipment with wet hands, damp clothing, or in the presence of water accumulation.

1.3.2. De-energization and Discharge Protocol

Strictly follow this procedure BEFORE opening the enclosure for maintenance:

- Physically isolate and lock out all AC and DC switches from both the equipment and utility grid sides.
- Verify zero voltage at all contact surfaces using a calibrated multimeter or voltage tester before proceeding.

1.3.3. Grounding Standards

- Establish the protective earth (PE) connection FIRST during installation and disconnect it LAST during removal.
- The equipment must maintain a permanent and reliable connection to the earth potential via PE cables, , with impedance meeting local electrical standards.
- Do not operate the equipment if the ground conductor is missing or damaged. Direct grounding of PV strings is prohibited unless an isolation transformer is added to the AC side.

1.3.4. Cabling and Connection Requirements

- Route cables away from heat sinks, ventilation vents, or other high-temperature areas. Ensure adequate safety clearance between cables and heat-generating components to prevent insulation degradation.
- Do not join or weld power cables. If necessary, use a longer cable meeting the required specifications.
- Ensure all terminals are tightened to the specified torque and cable insulation is intact. Damage caused by faulty external power systems or incorrect voltage is excluded from the warranty.

1.3.5. Ingress and Contamination Protection

- Prevent tool fragments, metal shavings, screws, nuts, or cable ties from falling into the equipment. Such materials can trigger short circuits, component failure, or power loss.
- Ensure water, condensation, or any liquids do not enter ventilation openings or internal spaces.
- The use of water, alcohol, oils, or solvents for cleaning electrical components, internally or externally, is strictly prohibited.

1.3.6. External Electrical Risk Protection

- The complete system must implement lightning protection compliant with IEC standards. Damage resulting from substandard lightning protection is excluded from the warranty.

- Consult local utility companies before selecting grid codes. Incorrect configurations may result in the revocation of operating permits.
- Equipment failures triggered by grid voltage surges or external power system faults are not covered by the warranty.
- Before installing and debugging the batteries, please prepare fire-fighting facilities in accordance with construction standards and regulations, such as fire sand and carbon dioxide fire extinguishers. Before putting them into operation, ensure that the fire-fighting facilities installed are in compliance with local laws and regulations.

1.4. Environment and Site Safety

	<p>NOTICE!</p> <ul style="list-style-type: none"> • The ground where the equipment are stored must be solid and reliable. • When maintaining a liquid-cooled battery system, maintain the battery clusters sequentially. That is, when maintaining a specific battery cluster, only the corresponding battery compartment door of that cluster may be opened. it is strictly prohibited to open multiple battery compartment doors simultaneously (unless multiple clusters require simultaneous maintenance operations). • After the liquid-cooled battery system maintenance is completed, the battery compartment doors should be closed immediately. after the doors are closed, the dehumidification air conditioner must first operate to control the humidity inside the compartment to 50% before the system can operate again.
--	---

1.4.1. Prohibited Installation Environments

Strictly prohibit deploying the equipment in the following environments that may compromise system integrity, trigger safety incidents, or void the warranty:

- **Flammable and Explosive Zones:** Do not install or operate the equipment in locations containing flammable or explosive gases, smog, chemical vapors, or dust.
- **High-Risk Water Areas:** Do not install the equipment directly under water pipes, air conditioning vents, ventilation openings, or windows prone to condensation or leakage. Ensure the installation site is above the historical highest water level and never in areas susceptible to flooding.
- **Extreme Thermal Stress:** Avoid installing the equipment in direct sunlight to prevent efficiency loss. Keep the equipment away from open flames or heat sources (e.g., heaters, boilers). Ensure ventilation and heat dissipation systems are never obstructed or covered.
- **Salt and Corrosive Environments:** Outdoor installation in salt-affected areas (e.g., within 500 meters of the coast) is prohibited unless the equipment holds specific protective certification. Avoid exposure to corrosive gases, volatile solvents, or metallic dust.

- **Avoid low-lying and flood-prone areas.** The installation site that the device is to be located must be higher than the highest water level in history. Since winds and wind-driven waves from rivers, lakes, and seas can affect the device, the foundation must be built higher than the maximum wave height in history.

1.4.2. Site Infrastructure & Structural Requirements

- Ground Support & Stability

The installation ground must be solid, level, and free from subsidence. Do not deploy the equipment on soft or spongy soil.

- Structural Verification

Before mounting, confirm that brackets, poles, or walls are stable and capable of safely supporting the total equipment weight and environmental loads to prevent tilting or collapse.

- Electromagnetic Limits

The magnetic field strength at the installation site should be less than 4 Gauss to ensure the proper operation of internal electronic components.

1.4.3. Vegetation & Site Cleanliness

- Vegetation Control

For outdoor installations, clear weeds around the equipment regularly. It is recommended to harden the ground beneath the equipment (e.g., using cement or gravel) according to the area specified in technical specifications (e.g., 3m x 2.5m).

- **Waste Removal:** Upon completion of installation, immediately remove all packaging materials, foam, plastics, and cable ties from the equipment area to eliminate fire hazards and maintain ventilation.

1.4.4. Fire emergency Protocols

- **Immediate Evacuation:** In the event of a fire, all personnel must leave the building or equipment area immediately.
- **Alarming:** After evacuation, immediately activate the fire alarm system or call local emergency services.
- **Prohibited Re-entry:** Do not re-enter the affected area under any circumstances until emergency responders confirm it is safe.

1.5. Mechanical Safety

1.5.1. Tool and Structural Integrity

- **Tool Compliance:** Only use complete tools certified by professional organizations. Do not use tools with cracks, scratches, or those past their calibration expiry. Ensure tools are not overloaded.
- **Paint Protection:** Promptly repair any paint scratches caused during transport or installation. Equipment with damaged coating must not be exposed for extended periods to prevent metal substrate corrosion.

1.5.2. Handling and Hoisting Safety

- **Mechanical Assistance:** When using forklifts or pallet jacks, ensure proper tine positioning and securely lock the equipment to the carrier with ropes before movement to prevent tipping.
- **Professional Hoisting:** Hoisting must be performed by certified professionals. Standing or walking beneath hoisted objects is strictly prohibited. Ensure the angle between hoisting ropes meets safety design requirements.

1.5.3. Elevated Work Standards

- Ladder selection

When performing live-line work, wooden or insulating material-made ladders must be used. Before use, it is necessary to ensure the ladder's load-bearing capacity and check the integrity.

- Stability requirements

For single ladders, maintain a 75-degree angle with the ground and implement anti-slip measures. If used to access a platform, the ladder must extend at least 1 meter above the platform level. Make sure the ladder is placed firmly and held steady.

- When working at heights, wear a safety helmet and safety harness or waist belt and fasten it to a solid structure. Do not mount it on an insecure moveable object or metal object with sharp edges. Make sure that the hooks will not slide off.

1.5.4. Drilling Prohibition

- Hardware damage risk









Any form of drilling on the equipment enclosure or structural components is strictly prohibited. Drilling will result in:



- Destroying seal integrity, allowing moisture and dust infiltration.
- Compromising Electromagnetic Compatibility (EMC) shielding.

- Metal shavings falling inside, triggering circuit board shorts or severe electrical incidents.
- Site preparatio



If drilling is required for site preparation (not on the equipment), pre-identify buried pipes and cables. Immediately clean all shavings after drilling to prevent them from entering the equipment area.

1.6. Labels On the Equipment

Symbols	Meaning
	<p>Warning - Electric Shock Hazard!</p> <p>Do not touch system connectors or terminals. Do not open the closed door unless proper lockout/tagout procedures and related training have been performed in accordance with local regulations and requirements.</p>
	<p>Warning - Fire hazard!</p> <p>Fire may occur under certain fault conditions.</p>
	<p>CAUTION symbol</p> <p>When you see this label, please slow down, be vigilant, carefully observe the surrounding environment, and follow the relevant safety regulations.</p>
	<p>Refer to user manual.</p> <p>Before operating the equipment, please read the user manual.</p>
	<p>Wear ear protection!</p> <p>Personnel entering this area or performing operation must wear hearing protection devices.</p>
	<p>Waste holders must not dispose of such equipment in regular trash bins. instead, they must process it through dedicated collection networks.</p>
	<p>Waste holders must not dispose of such equipment in regular trash bins. instead, they must process it through dedicated collection networks. Additionally, batteries containing more than 0.004% lead must be marked with the chemical symbol Pb for the metal concerned.</p>
	<p>Protective earthing.</p> <p>Connect the metal casing of the electrical equipment to the ground to prevent electric shock accidents.</p>

	<p>CE certification. This equipment has passed CE certification</p>
	<p>RoHs symbol. In accordance with 2011/65/EU regulations, the equipment imposes restrictions on the use of specific hazardous substances in electrical and electronic equipment.</p>
	<p>Arc Flash and Shock Hazard. The operator must wear the appropriate personal protective equipment (PPE).</p>

1.7. Lockout/Tagout Guidance

	<p>DANGER!</p> <p>Always follow all applicable lockout/tagout procedures. Failure to follow proper lockout/tagout procedures may result in serious injury or death.</p> <p>When power is applied to the equipment, dangerous voltages exist on certain components. To prevent accidental death or injury, non-professionals should not touch any components inside the enclosure. To reduce the risk of electric shock, ensure all equipment is reliably grounded.</p>
	<p>WARNING!</p> <p>The doors of the equipment must remain closed unless access to the interior is required. If possible, personnel should maintain a safe distance from the enclosure when the equipment is powered. When working near the equipment, always comply with local and national lockout/tagout guidelines. Lockout and tagout procedures must meet or exceed the aforementioned requirements.</p>

Attention

All guidelines proposed in the Chint safety document. Before entering a potentially hazardous area or starting work on the equipment, please complete the following regulations:

- Identify and wear protective clothing and protective shoes.
- Identify and isolate all power sources and stored energy.
- Use appropriate lockout/tagout devices. When locking/tagging the equipment, do not touch anything inside the equipment unless explicitly instructed in the work procedure.
- Before starting work, complete the site-specific lockout/tagout procedures and safety checklist.

2. System Introduction

System application

This equipment adopts a modular design concept and is widely used in scenarios such as renewable energy integration, commercial and industrial (C&I), and utility applications. The system features an "All in one" design, eliminating the need for auxiliary electrical design and reducing on-site workload. At the same time, the top explosion-proof design significantly enhances fire safety. The system supports flexible 2/4-hour configuration schemes and offers higher energy density, superior cycle efficiency, and longer service life, ensuring efficient and reliable long-term operation. The equipment is mainly suitable for system solutions such as BCP (Business Continuity Plan, emergency power supply in case of accidents or disasters), peak shaving and valley filling, Photovoltaic (PV) self-consumption, Virtual Power Plant (VPP) or grid dispatch, improving energy utilization efficiency and enhancing power quality. The equipment has advantages such as high efficiency, energy saving, environmental protection, high integration, easy installation, standardized solutions, intelligent control, remote monitoring, and easy operation, with stable performance, safety, reliability, and long service life.

Advantage

- Intelligent Management:

The equipment is composed of high-capacity battery cells, serving as an intelligent energy storage device that supports management, dispatch, grid connection, black start, and easy transportation. The main components of the system include the PCS, BMS, and battery PACK. The PCS performs stable charging and discharging of battery clusters based on the battery status and operational mode requirements provided by the LEMS or BMS.

- High Reliability:

The BMS ensures the battery cells always operate well through real-time monitoring, automatic balancing, automatic inspection protection, and power data requests. The black start system supports the operation of the energy storage power station during power outages, solving customers' electricity usage challenges.

- High Flexibility:

The entire station's Energy Storage System (ESS) can be flexibly configured according to user requirements. It can be designed for grid-connected wind/PV energy storage, off-grid energy storage, etc., making it a powerful, stable, reliable, and technically comprehensive energy storage product.

2.1. Model Description

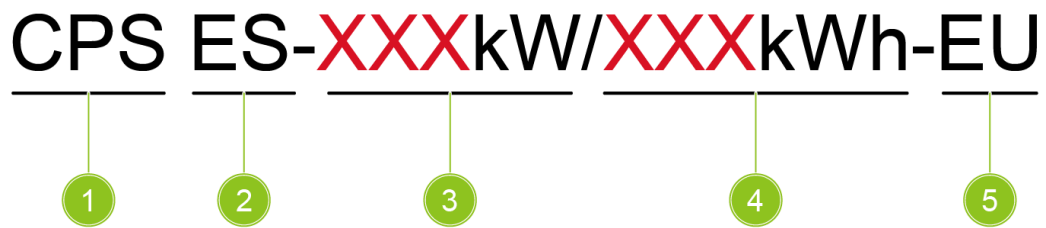

Fig. 2-1 Model introduction

No	Definition
1.	Company name: Chint Power System
2.	Product category: Energy Storage
3.	Power , Unit: kW
4.	Total Capacity , Unit: kWh
5.	Region: EU (Europe)

2.2. Dimensions and Appearance

Dimensions (with lifting lugs)

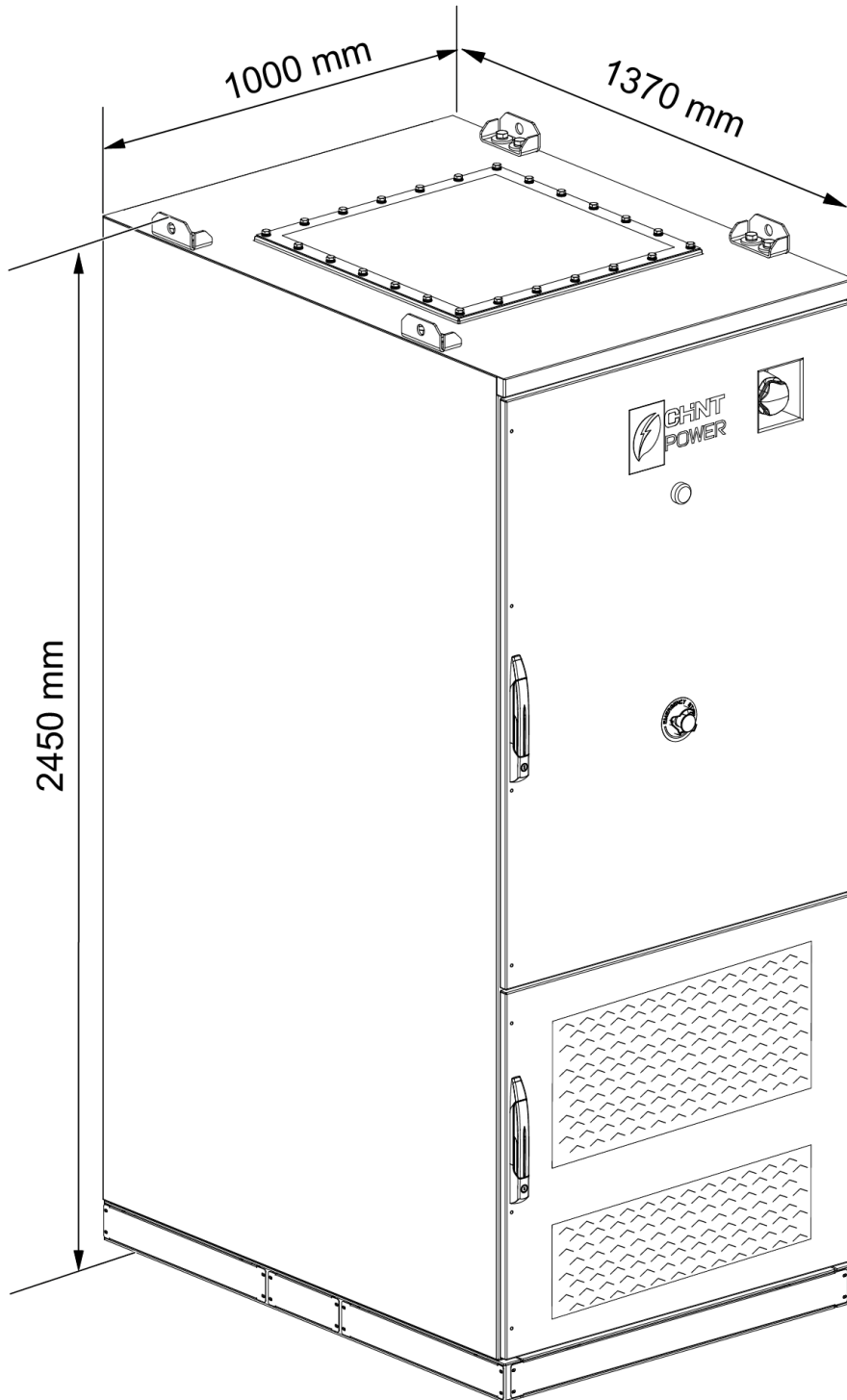

Fig. 2-2 Dimensions

Appearance

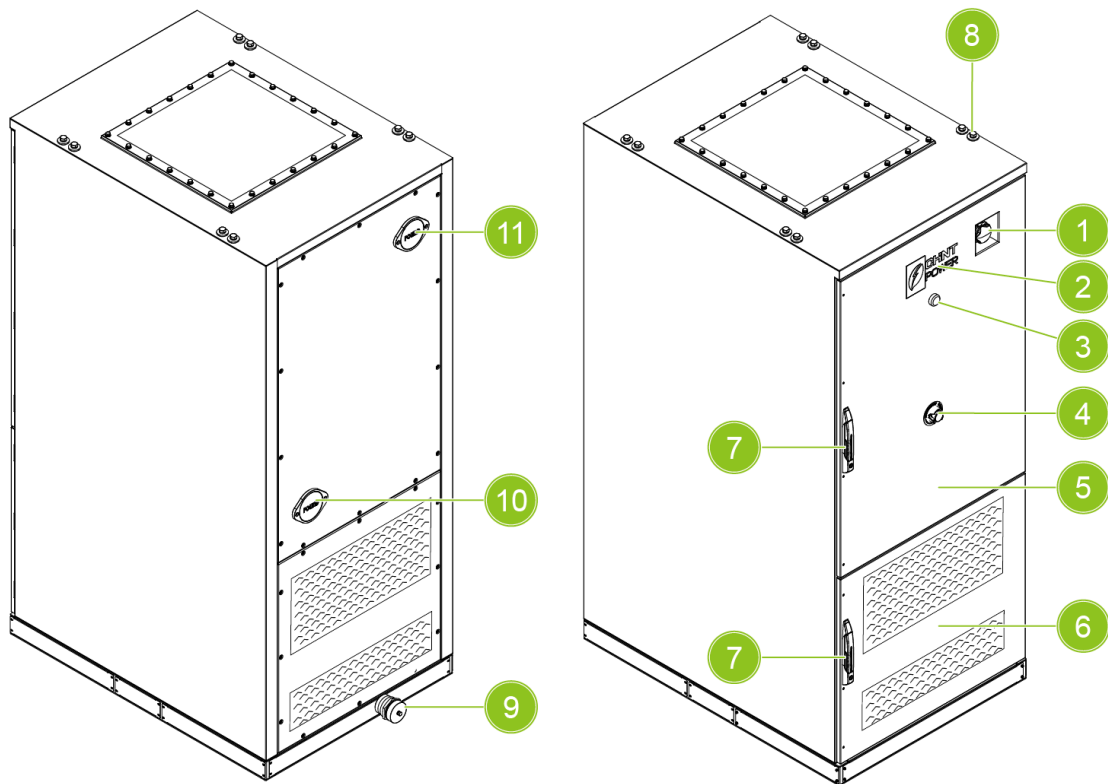

Fig. 2-3 Appearance

- | | | |
|--------------------------|-----------------------------|-----------------------------|
| 1. Alarm | 2. CHINT logo | 3. Working indicator |
| 4. Emergency stop button | 5. Battery compartment door | 6. Cooling compartment door |
| 7. Door handle | 8. Lifting point | 9. Water inlet joint |
| 10. Air inlet valve | 11. Air outlet valve | |

2.3. Parameters

Item	Parameter	Note
Cell capacity	314Ah	0.5C Charging and discharging rate
Series-parallel mode	1P260S	N.A.
DC nominal voltage	832V	N.A.
DC nominal capacity	261.248kWh	Standard Discharge
Cabinet Size	1000*1370*2415 mm	See the drawings for details
Weight	Appr. 2.55 T	Full load
End-off voltage	728V	Temperature: T > 0°C
Charging cut-off voltage	936V	N.A.
Rated charge/discharge current	157A	(25±2) °C
Cycle efficiency	≥89%	Without auxiliary transformer
Communication mode	CAN、RS485、TCP/IP	N.A.
Run temperature range	-30°C~55°C (>45°C derate)	N.A.
Storage temperature range	-30~60°C	N.A.
Operating conditions	(25±5)°C	Product lifespan guarantee for operating conditions
Cooling	Battery: Liquid cooling PCS: Forced air cooling	N.A.
Fire fighting system	Aerosol	The fire-fighting medium can be changed according to customer requirements. Among them, the water spray system is optional.
IP level	Battery compartment IP55 Electrical compartment IP54	N.A.
Noise	<75dB	1 meter away, 1.7 meters high, 35 degrees Celsius
Rated AC output power	125kW	

2.4. Nameplate

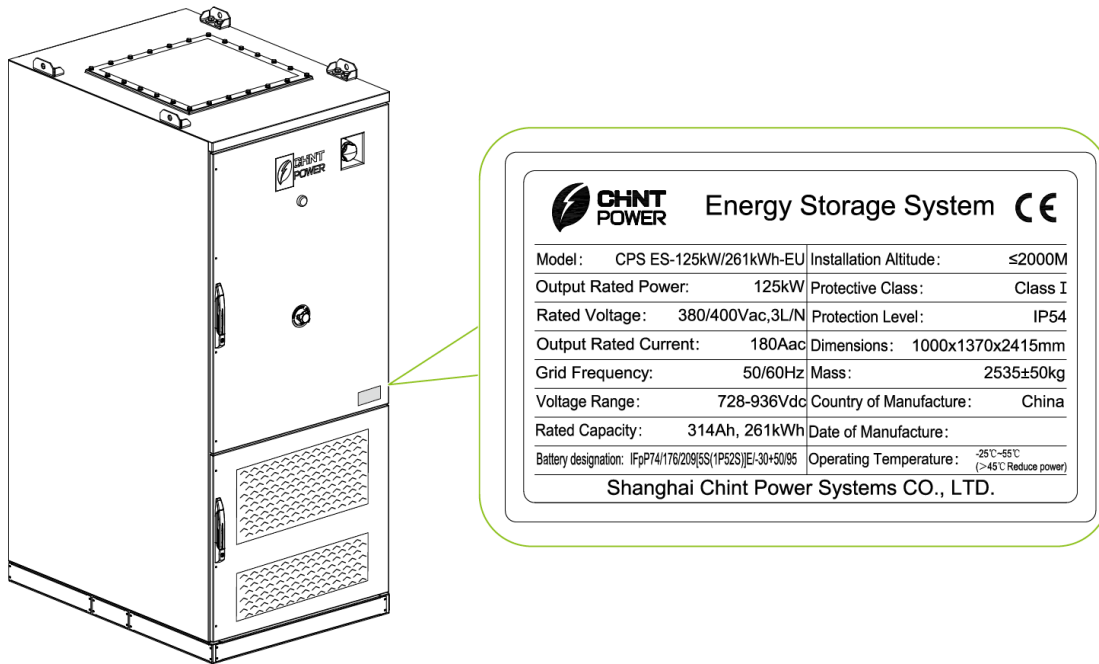

Fig. 2-4 Dimensions and appearance

2.5. System Annotation

Overview

This equipment consists of multiple energy storage components, including battery system, PCS, LEMS, power distribution box, thermal management system and fire safety system. The detailed system annotation is shown in the following figure:

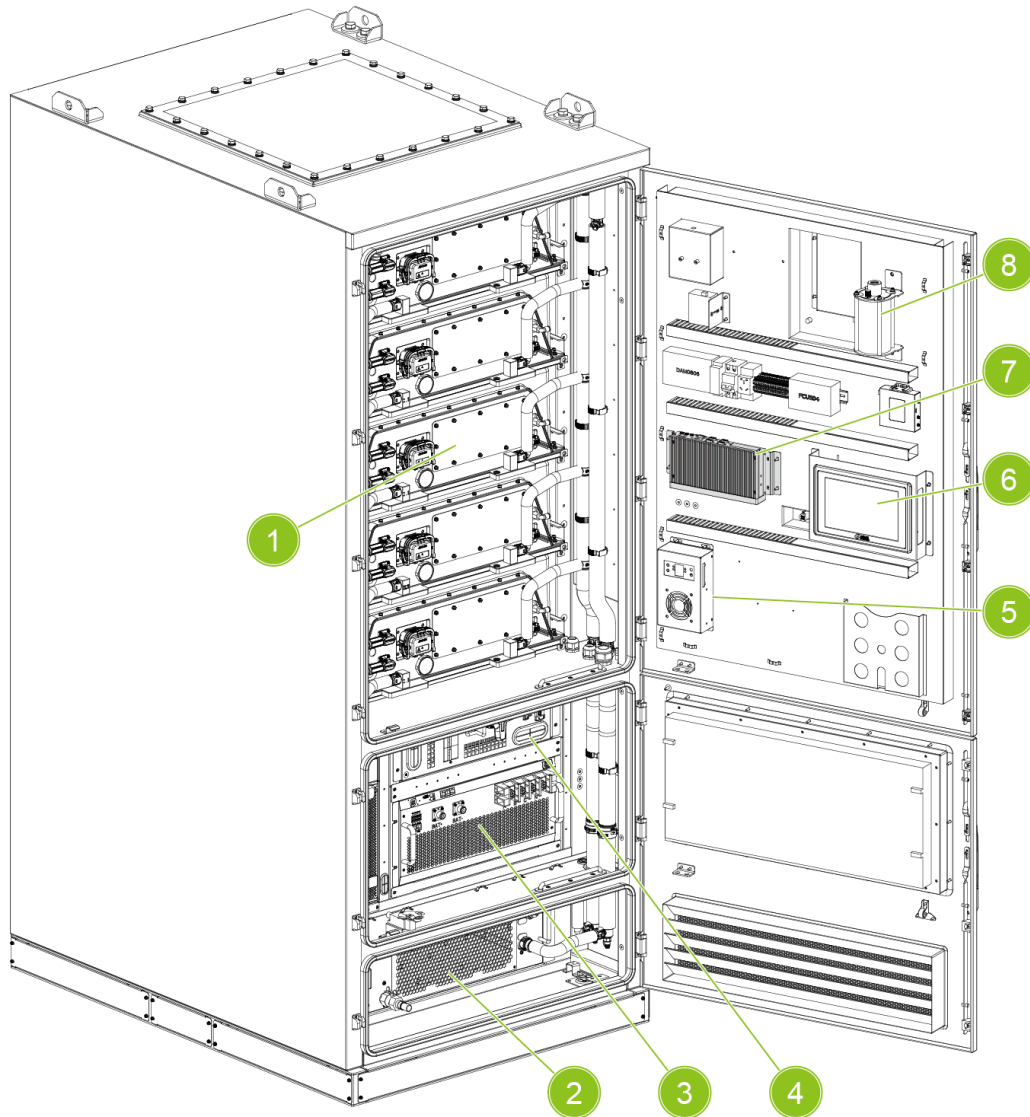

Fig. 2-5 System Annotation

- | | |
|-------------------|------------------------------|
| 1. Battery system | 2. Thermal management system |
| 3. PCS | 4. Power distribution box |
| 5. Dehumidifier | 6. ESMU |
| 7. LEMS | 8. Fire extinguisher |

2.6. Battery System

Overview

The battery system mainly consists of battery PACK, high voltage box, support frame, and battery management system (BMS).

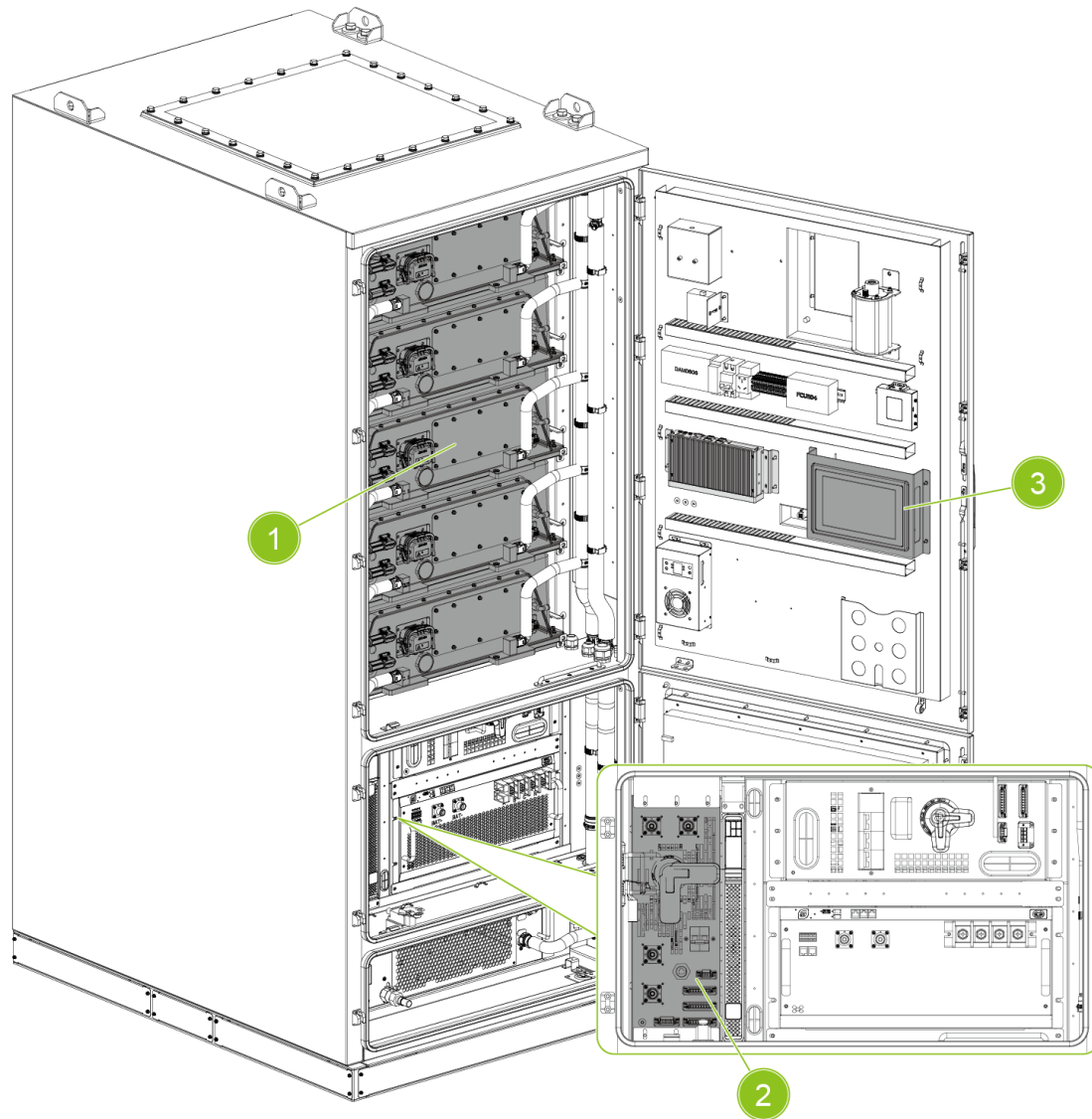

Fig. 2-6 Battery system

1. Battery PACK

2. High voltage box

3. ESMU

2.6.1. Battery Pack

Overview

The battery PACK is composed of Lithium Iron Phosphate (LFP) cells in a 1P52S configuration. The positive and negative positions of the Battery PACK are positive at the top and negative at the bottom, as shown below:

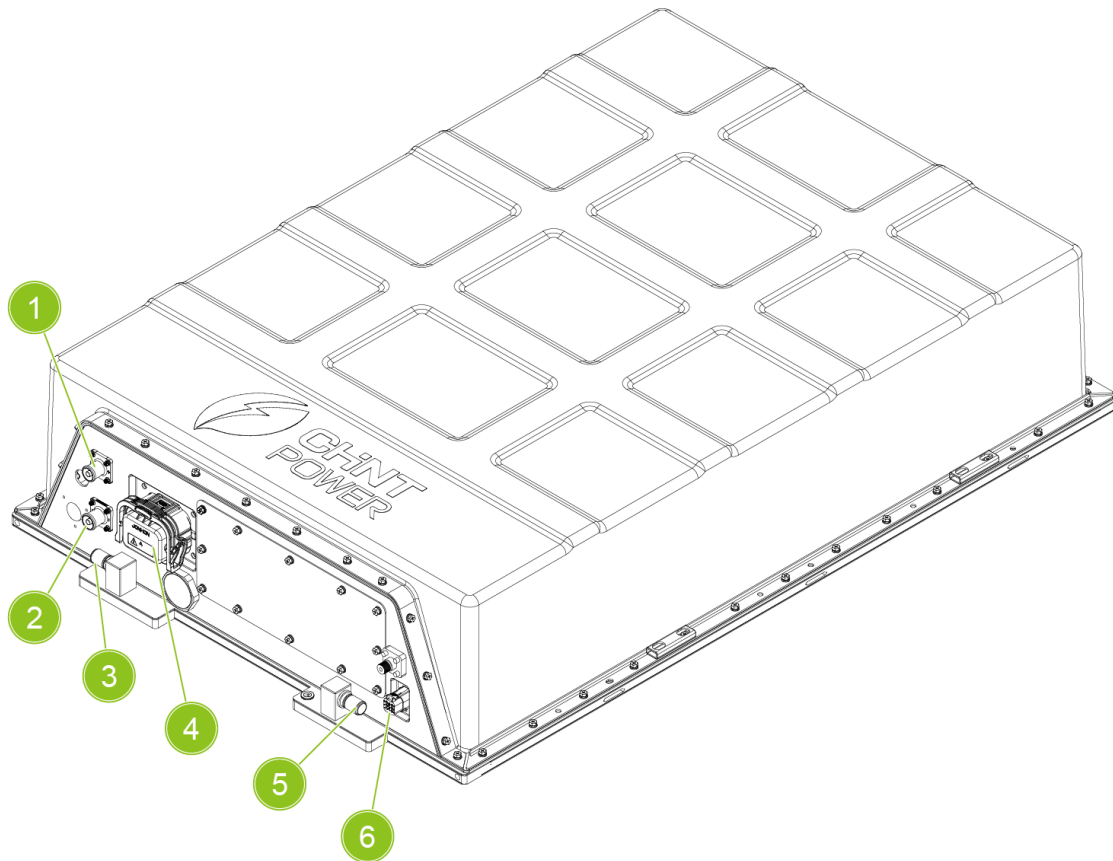

Fig. 2-7 Battery PACK

- | | | |
|------------------------------------|-------------------------|----------------------------|
| 1. Positive terminal | 2. Negative terminal | 3. Liquid cooling outlet |
| 4. MSD (Manual Service Disconnect) | 5. Liquid cooling inlet | 6. Communication interface |

2.6.2. Battery Management System (BMS)

Overview

The BMS adopts a 3-level architecture, and the hardware consists of ESBMM, ESBCM, and ESMU. The installation locations of the BMS components are as follows:

Table 2-1 BMS Components and location

Device level	Device name	Installation location	Function
Level 1, Battery PACK level	ESBMM	Inside the battery PACK maintenance panel	Detect the voltage and temperature information of the cells inside the battery PACK
Level 2, Battery cluster level	ESBCM	Inside the High voltage box (refer to Fig. 2-10 High voltage box overview)	Data collection, analysis, and decision-making. Cluster-level protection. Information uploaded to ESMU.
Level 3, System level	ESMU	On the cabinet door (refer to Fig. 2-6 Battery system)	Collect information from each ESBCM and communicate with LEMS and SCADA

ESBMM location

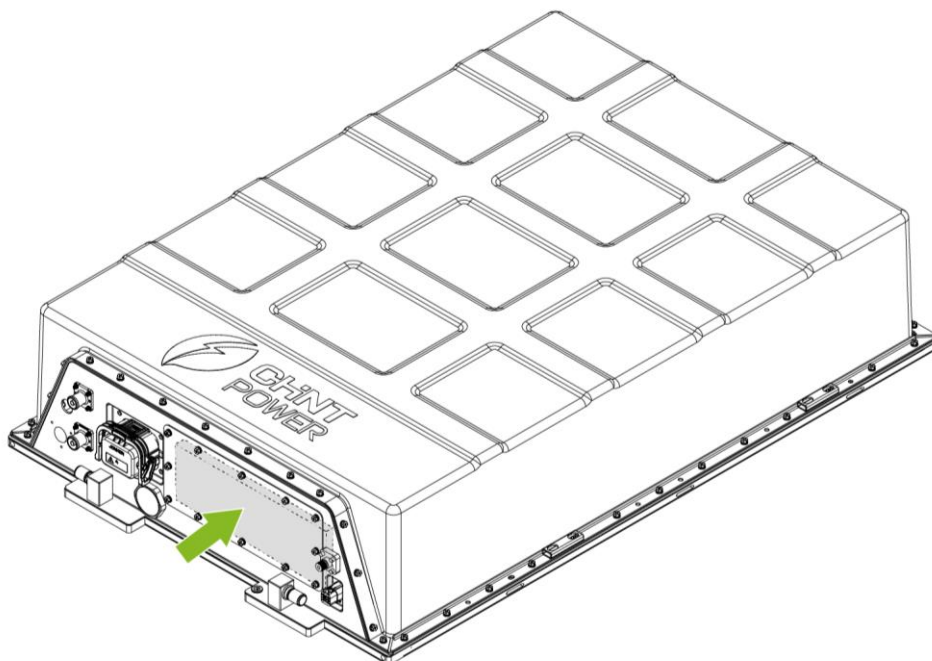

Fig. 2-8 ESBMM location

ESMU

In the interface distribution of ESMU, Port 6 is the power port, port 5 is the Ethernet communication port, Ports 1, 2, 3, 4, and 8 are communication ports, port 7 (USB) is the data export and firmware upgrade import port, and SW is the auxiliary firmware button.

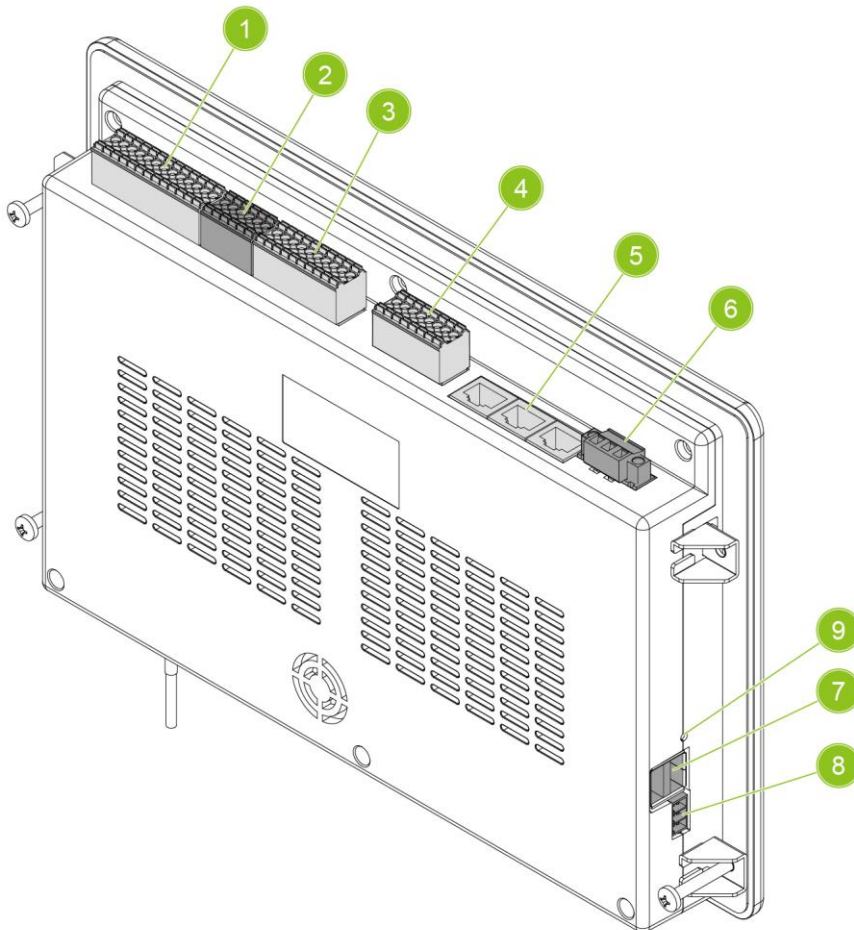

Fig. 2-9 ESMU interface

- | | | |
|-------------|--------------|---------------|
| 1. COM port | 2. COM port | 3. COM port |
| 4. COM port | 5. LAN 0,1,2 | 6. Power port |
| 7. USB port | 8. COM port | 9. SW button |

ESMU has a total of 11 output dry contact interfaces, located on all pins of Port E.

The interface definitions of ESMU are as follows:

Table 2-2 ESMU interfaces

Port name	No.	Port definition	Function description	Recommended use
Power port	1	V+	Power supply positive input	Power Input
	2	V-	Power supply negative input	

Port name	No.	Port definition	Function description	Recommended use
	3	PE	System grounding (protective earth bonding)	
LAN	/	LAN0	100M/1000M Ethernet	LEMS
	/	LAN1	100M/1000M Ethernet	LEMS
	/	LAN2	10M/100M Ethernet	ESBCM
COM port	/	/	/	/
USB	/	/	Data export and upgrade program import port	/
SW	/	/	Auxiliary solid button	/

2.6.3. High Voltage Box

Overview

The high voltage box consists of protective devices and ESBCM. The layout of the high voltage box is shown in the following figure:

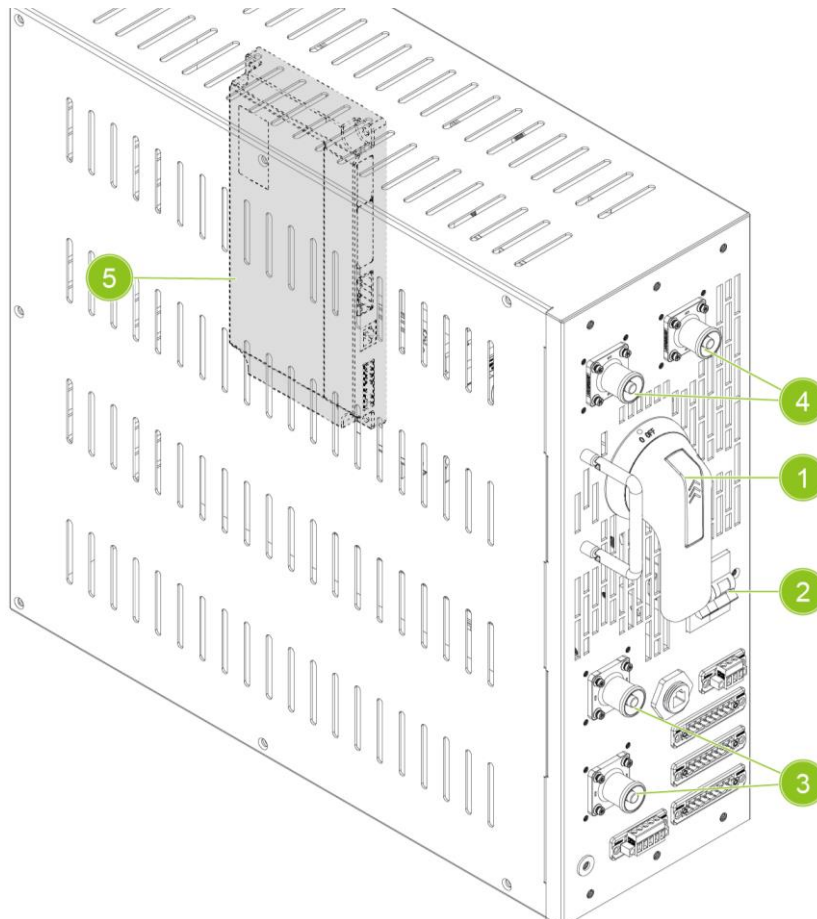

Fig. 2-10 High voltage box overview

No.	Name	Function description
1	Disconnecter	Realize high-voltage on/off control of the battery cluster's DC side.
2	Miniature circuit breaker	Protect the secondary signal circuit of the high voltage box, supporting overload/short-circuit protection.
3	Battery cluster plug	High voltage DC interface between the battery PACK and the high voltage box.
4	PCS plug	High voltage DC interface connecting the high voltage box to the PCS DC side.
5	ESBCM	Data collection, analysis and decision-making Cluster-level protection Information uploaded to ESMU

Communication input/output interfaces

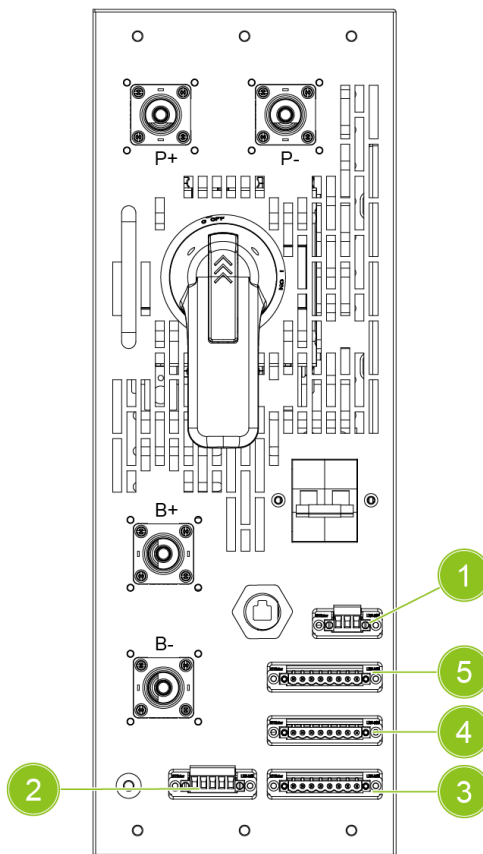

Fig. 2-11 High voltage box

- 1. J1 port
- 2. J2 port
- 3. J3 port
- 4. J4 port
- 5. J5 port

The high voltage box is connected to the battery through "B+" and "B-" terminals, and connected to the DC side of PCS through "P+" and "P-" terminals on the front of the control box. The schematic diagram of high voltage box interfaces is shown above, and the definitions of power and communication input/output interfaces are shown in the following table:

Table 2-3 High voltage box overview

Port name	No.	Definition	Function description	Remarks
High voltage box 24VDC power supply Port J1	1	V+	External 24VDC power input, supplying power to internal components of the high voltage box	
	2	V+		
ESBMM communication port J2	1	IP1	Daisy chain communication	Connect to the last ESBMM IP2/IM2
	2	IM1	Daisy chain communication	
	3	IP2	Daisy chain communication	Connect to the first ESBMM IP2/IM2
	4	IM2	Daisy chain communication	
Communication port J3	1	2H	Reserved	
	2	2L		
	3	0H	Reserved	
	4	0L		
	5	1H	PCS communication	
	6	1L		
	7	A	Liquid cooling unit/IO module/dehumidifier communication	Hand in hand
	8	B		
ESBCM DI port J4	1	DI2H	Low concentration alarm for combustible gas detector	
	2	DI4H	High concentration alarm for combustible gas detector	
	3	V1+	24V+	
	4	DI5L	Standby	
	5	DI7+	The sound and light alarm operation	

Port name	No.	Definition	Function description	Remarks	
	6	DI7-			
	7	DI8+	Standby		
	8	DI8-	Standby		
ESBCM port J5	DO	1	D04L	Red light	
		2	D05L	Green light	
		3	D06L	Standby	
		4	V2+	24V+	
		5	DO7+	Sound and light alarm operation	
		6	DO7-		
		7	DO8+	Standby	
		8	DO8-	Standby	
RJ45	1	LAN	Display control communication		

2.7. Power Conversion System (PCS)

Overview

The power conversion system is a conversion device between the grid and battery, which can charge and discharge the battery. It can invert DC power from the battery to AC power that can be connected to the grid and rectify AC power from the grid to DC power that can be charged into the battery. The power conversion system can be used in grid-connected mode or off-grid mode.

The power conversion system adopts single-stage topology, and the DC voltage input range is 690-950 V.

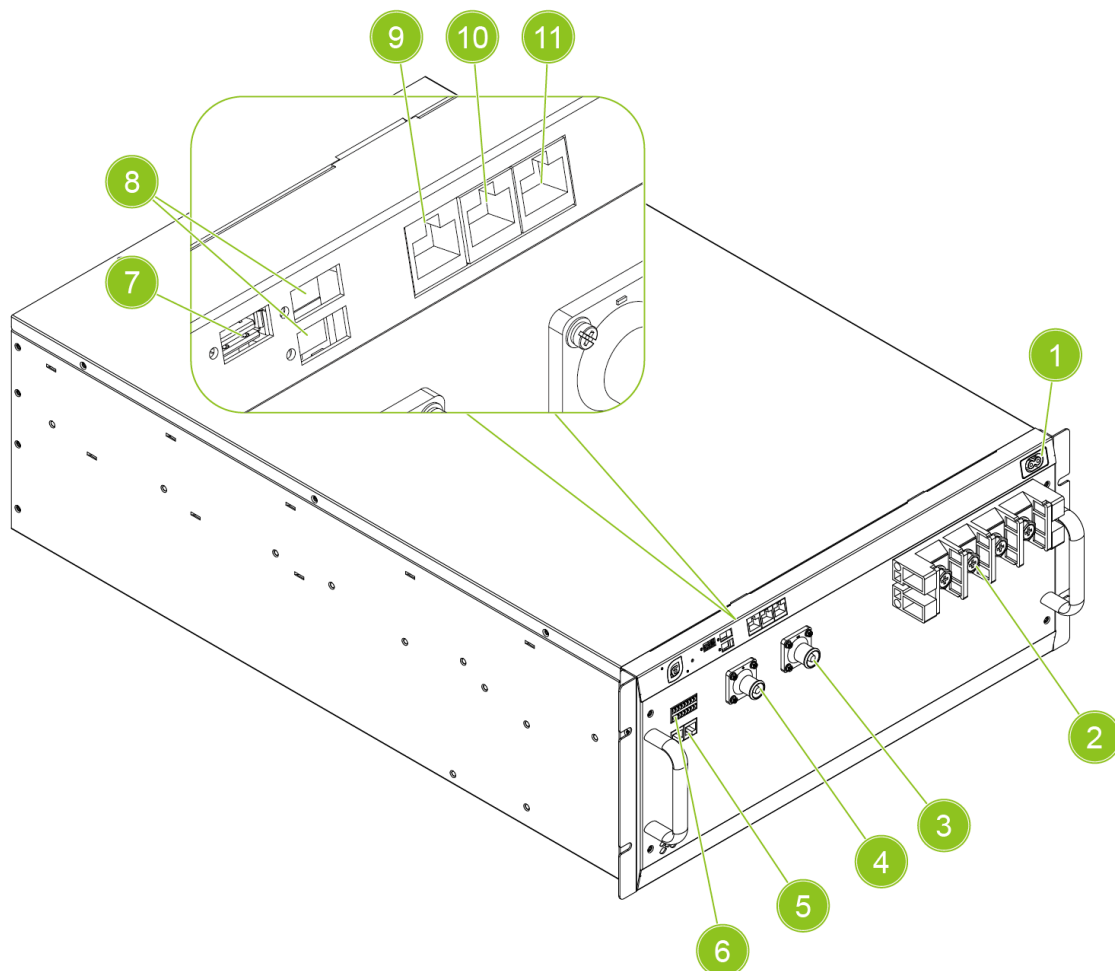

Fig. 2-12 PCS overview

- | | | |
|--------------------------------------|----------------|-----------------------------|
| 1. Power interface for commissioning | 2. AC terminal | 3. DC terminal (-) |
| 4. DC terminal (+) | 5. COM port | 6. Pluggable Terminal Block |
| 7. USB | 8. Addr port | 9. ETH port |
| 10. COOM3 port | 11. Test port | |

The topological graph of the power conversion system is illustrated as follows:

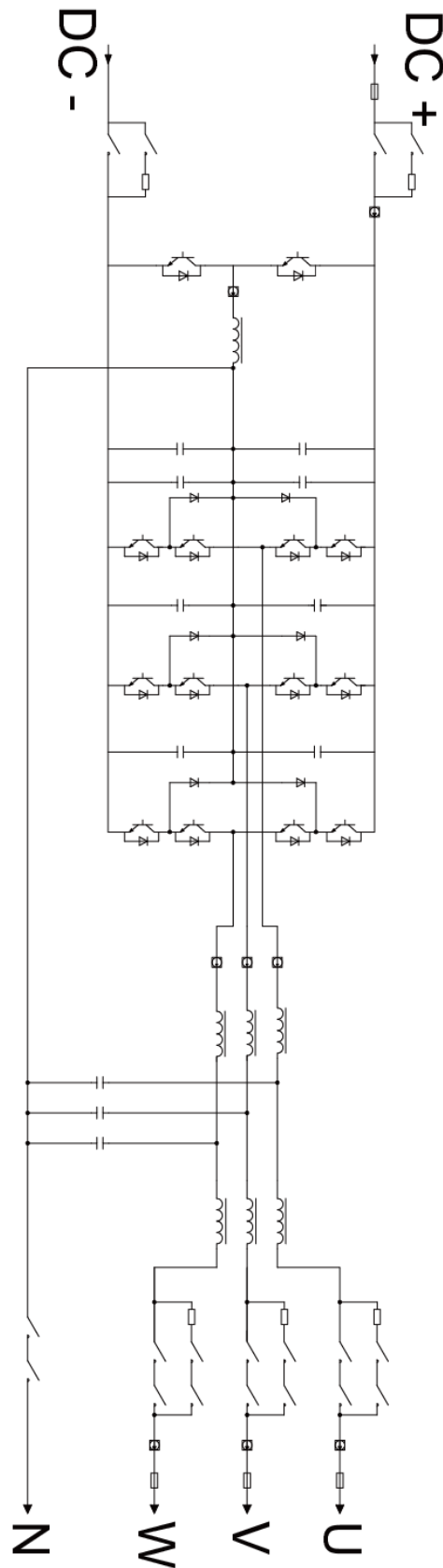

Fig. 2-13 Diagram of PCS

2.8. Local Energy Management System (LEMS)

Please refer to Fig. 2-5 System Annotation to see the LEMS location.

Overview

The Local Energy Management System (LEMS) is the energy dispatch and management center of the ESS. LEMS is the brain of the ESS, mainly responsible for collecting all BMS data, PCS data, and grid-side data, issuing control commands to various parts, controlling the operation of the entire ESS, and reasonably arranging the work of the PCS. The system can operate automatically according to preset charging/discharging time, power, and operation modes, or it can operate by accepting dispatch commands.

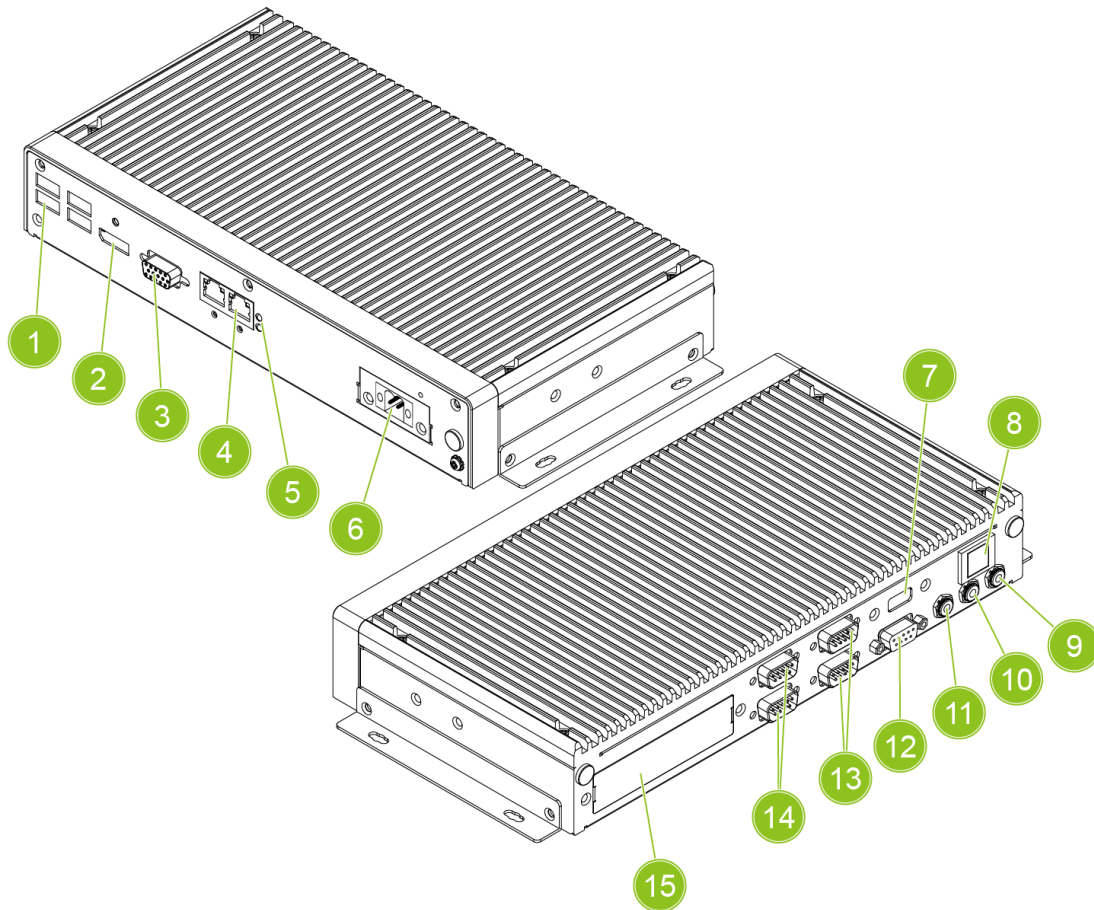

Fig. 2-14 Interfaces of LEMS

- | | | | |
|------------------|---------------|-------------------|------------------|
| 1. USB 1-4 | 2. HDMI | 3. VGA | 4. LAN 1 & 2 |
| 5. PWR & HDD led | 6. DC input | 7. USB 5 | 8. On/Off button |
| 9. LINE-IN | 10. LINE-OUT | 11. MIC | 12. Digital IO |
| 13. COM 2 & 4 | 14. COM 1 & 3 | 15. i door module | |

2.8.1. LEMS Control System Diagram

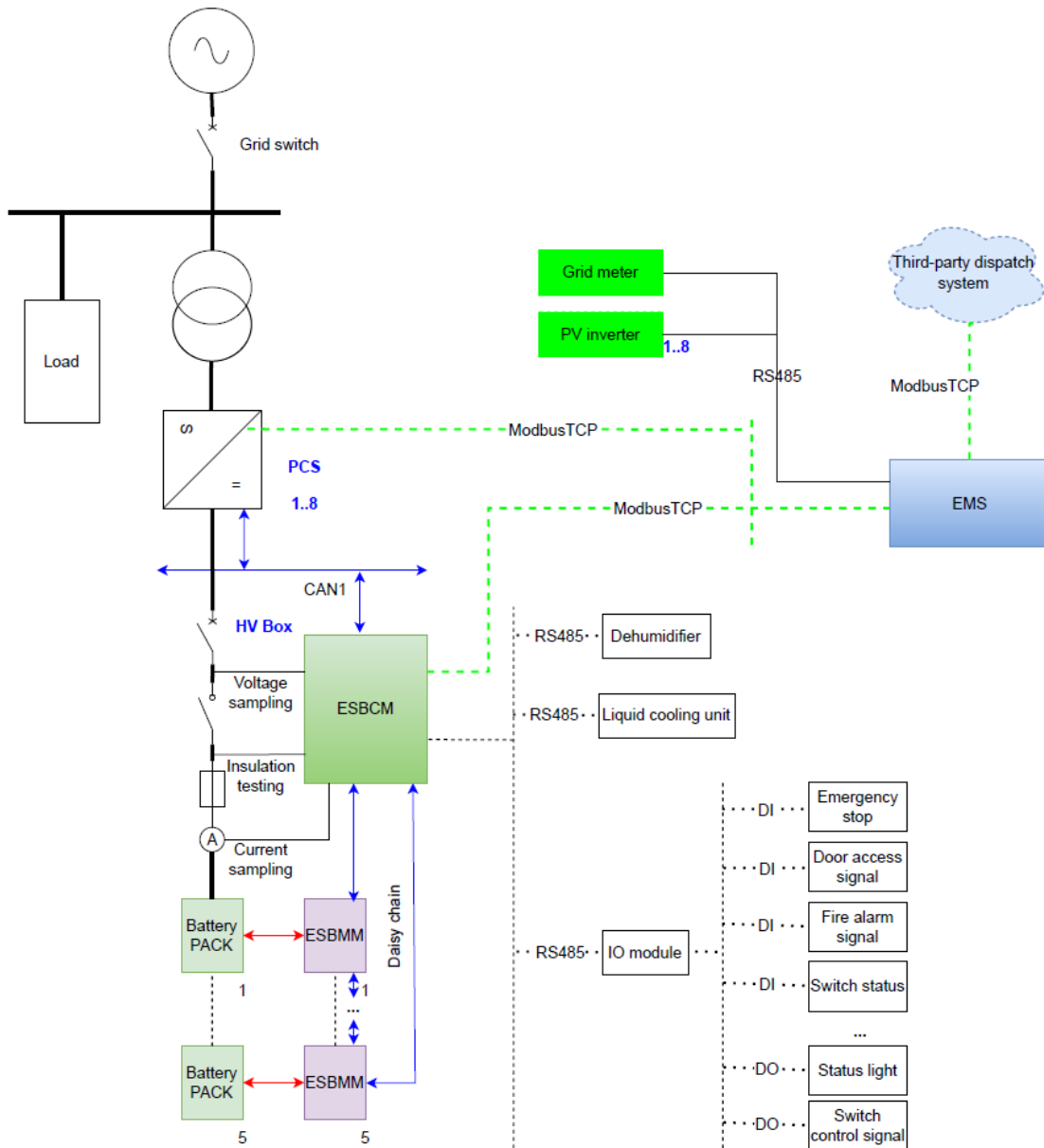

Fig. 2-15 LEMS control system diagram

2.8.2. System Functions

Overview

This system is suitable for microgrid systems that include energy storage, PV, and loads (including critical loads and general loads). It has the functions of maximizing PV output, smoothing load demand peaks, peak-valley power dispatch, and preventing power backflow.

- Maximize PV Utilization

This LEMS can maximize PV power generation by monitoring the generation and consumption status in the microgrid. When the PV power generation in the microgrid exceeds the total load consumption, the

LEMS can store the excess power in the ESS and release it when the microgrid load increases, achieving PV energy time-shifting and maximizing PV utilization.

- Smooth the peak load demand

LEMS can use energy storage to smooth internal load fluctuations. When the PV participates in output and the load power still exceeds the set demand limit, LEMS controls the energy storage output to smooth the excess demand, thereby improving the microgrid's economy.

- Power Limit

For microgrids that do not have surplus electricity to feed into the grid, this LEMS provides power limit control functionality. When it detects that the microgrid energy is below the power limit warning threshold, LEMS proactively adjusts energy storage and PV to avoid power limit, preventing the occurrence of power limit conditions.

- Used as a backup power supply for critical loads

When the system scheduling option of this LEMS is selected as backup, the LEMS ensures that the energy storage SOC is not lower than the backup SOC set by the system during operation, to ensure that important loads can be provided with backup power when the microgrid is off-grid.

- Peak shaving and valley filling

This LEMS can set strategies by time period, setting the PV energy time shift to fully charge the energy storage during the low electricity price period, and setting peak shaving and valley filling to release the energy storage power during the high electricity price period, thus achieving the function of peak shaving and valley filling.

- Microgrid status monitoring

This LEMS can access the control page by logging into the operation platform established on the local network, obtain the working status of PV and energy storage in real time, and perform off-grid and grid-connected switching. This LEMS can also send the basic information of operation to a third-party platform for data display.

2.8.3. Communication Connection Requirements

- For pure storage applications, LEMS needs to be connected to the grid-connected meter (Modbus-RTU protocol), while LEMS, PCS, and BMS use Modbus-TCP protocol.
- For photovoltaic storage applications that require control of PV inverters, LEMS needs to be connected to the grid-connected meter and PV inverter (Modbus-RTU protocol).
- For pure off-grid applications, LEMS needs to be connected to the PV inverter.

UPS

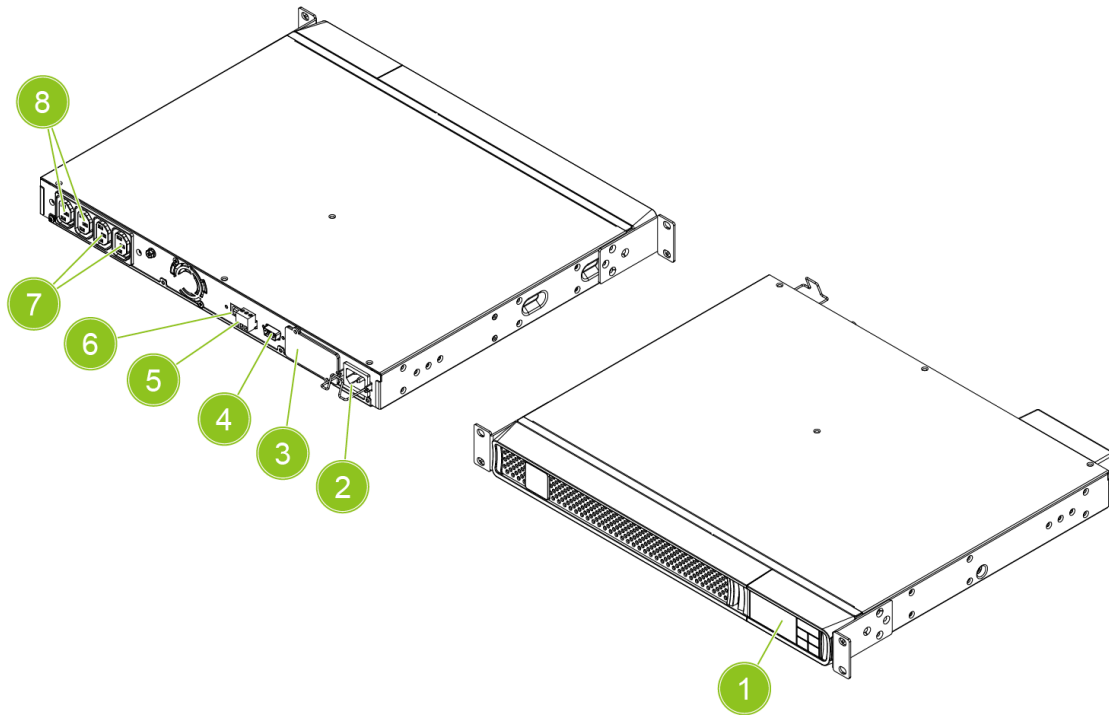

Fig. 2-18 UPS interface

- | | | |
|--|---|---|
| 1. Control panel | 2. Input AC power source | 3. Slot for optional communication card |
| 4. RS232 communication port | 5. Connector for ROO (Remote On/Off) control and RPO (Remote Power Off) | 6. USB communication port |
| 7. Outlet group (programmable outlets) | 8. Primary group (critical equipment) | |

2.10. Thermal Management System

System overview

The thermal management system use a liquid cooling unit to adjust the battery temperature within an appropriate range, and uniformly control the temperature of each battery through liquid cooling pipelines and liquid cooling plates.

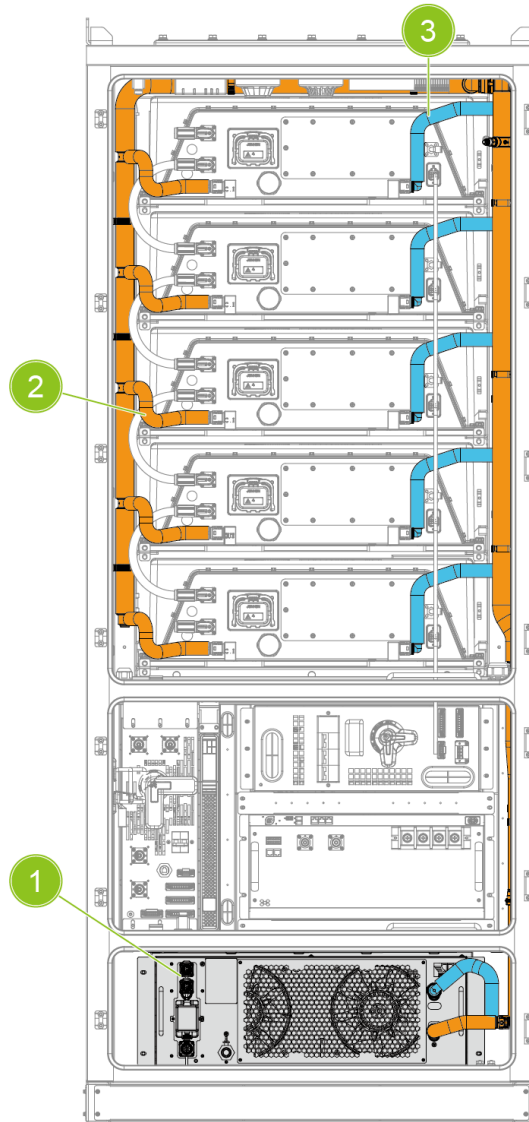

Fig. 2-19 Thermal management system

1. Liquid cooling unit

2. Hot coolant pipe

3. Cold coolant pipe

Liquid cooling unit

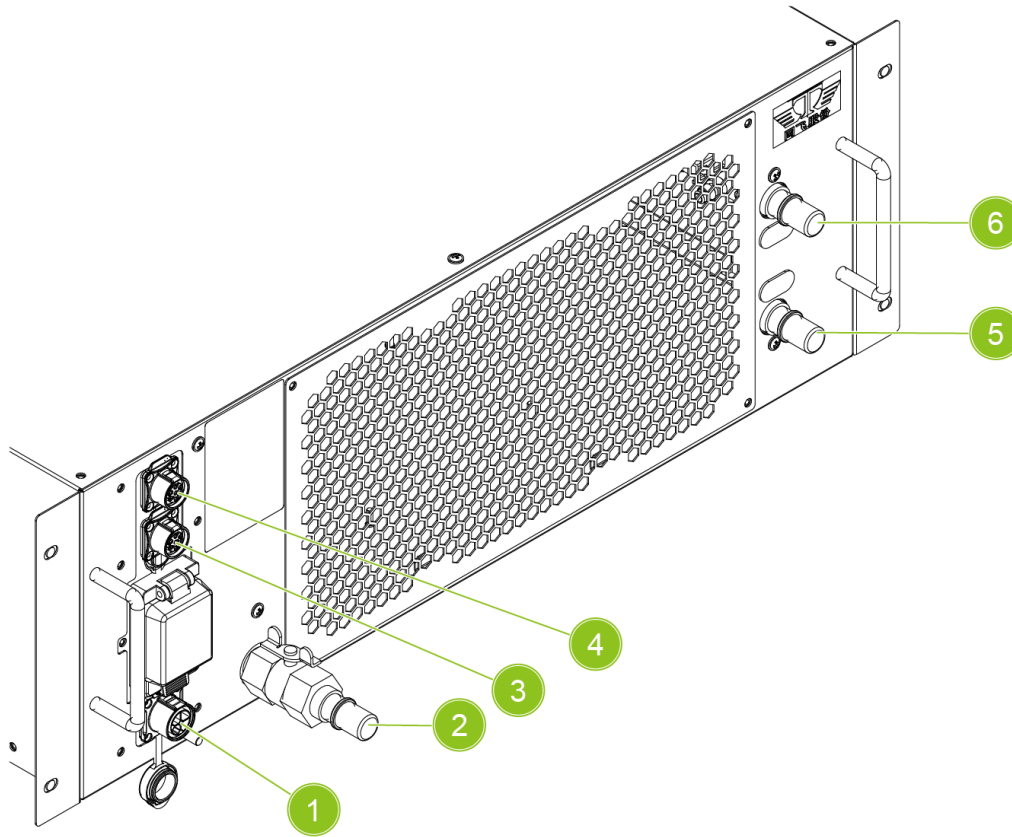

Fig. 2-20 Liquid cooling unit overview

- | | | |
|-------------------------|---|--------------------------------|
| 1. Power aviation plug | 2. Coolant filling / drainage connector | 3. Communication aviation plug |
| 4. Screen aviation plug | 5. Coolant inlet port | 6. Coolant outlet port |

2.11. Fire Safety System

System overview

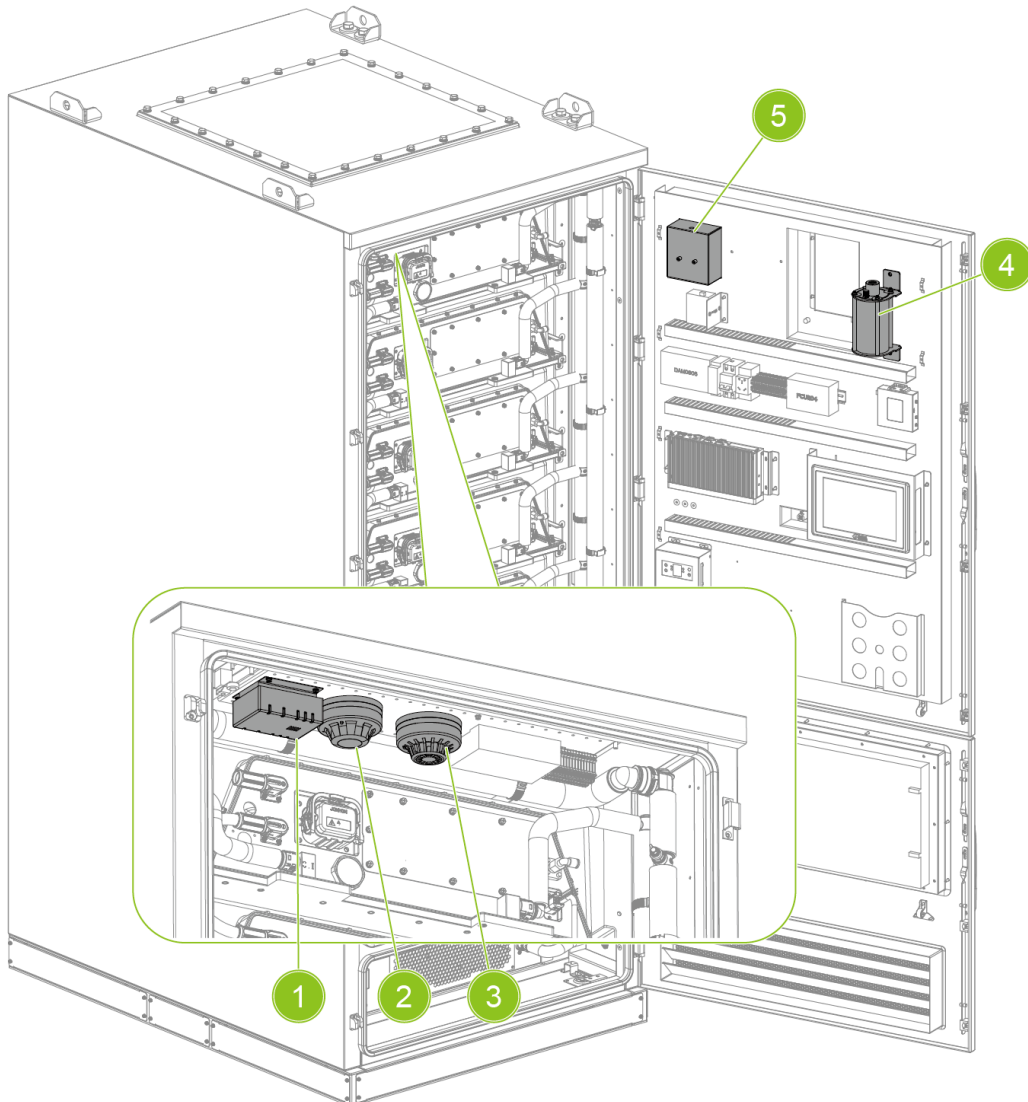

Fig. 2-21 Fire safety system

- | | | |
|------------------------------|--------------------------|-----------------------|
| 1. Combustible gas detector | 2. Smoke detector | 3. Temperature sensor |
| 4. Fire extinguishing device | 5. Sound and light alarm | |

The fire resistance time of the equipment body reaches 60 minutes, meeting the fire protection requirements. The cabinet is equipped with an automatic detection, alarm and aerosol fire suppression system. The entire fire protection system complies with the regulations and certifications of the project site. There is a fire alarm device inside the equipment, and the fire alarm can be immediately noticed when the cabinet door is opened or closed.

Fire detection

"Smoke detector" and "temperature sensor" have been installed, and they are connected to the "signal input/output module" and the "sound and light alarm" through it.

When the sensitivity of smoke exceeds 2.5%/m, or the temperature rises above 10°C per minute, the system may consider there is a fire risk and trigger the local alarm system "sound and light alarm". At the same time, it will be reported to the background monitoring system for remote notification.

Fire alarm system

There is a manual/electrical fire alarm system, including an automatic smoke detector. When activated, it will warn all personnel near the equipment.

There is a fire alarm device inside the cabinet, and personnel close to the equipment can immediately notice the fire alarm.

Fire suppression system

Sufficient and correctly types of fire extinguishers are arranged in the equipment to handle the risks within the cabinet. These fire extinguishers need to undergo routine inspections every 6 months.

The automatic fire suppression system (including fire extinguishing agent) in accordance with NFPA 2001 will be automatically triggered. The BMS starts the protection system and cuts off all power supplies. all fans and liquid cooling machines will stop working to prevent fresh air from entering the container.

2.12. Architecture Diagram

2.12.1. Electrical Architecture Diagram

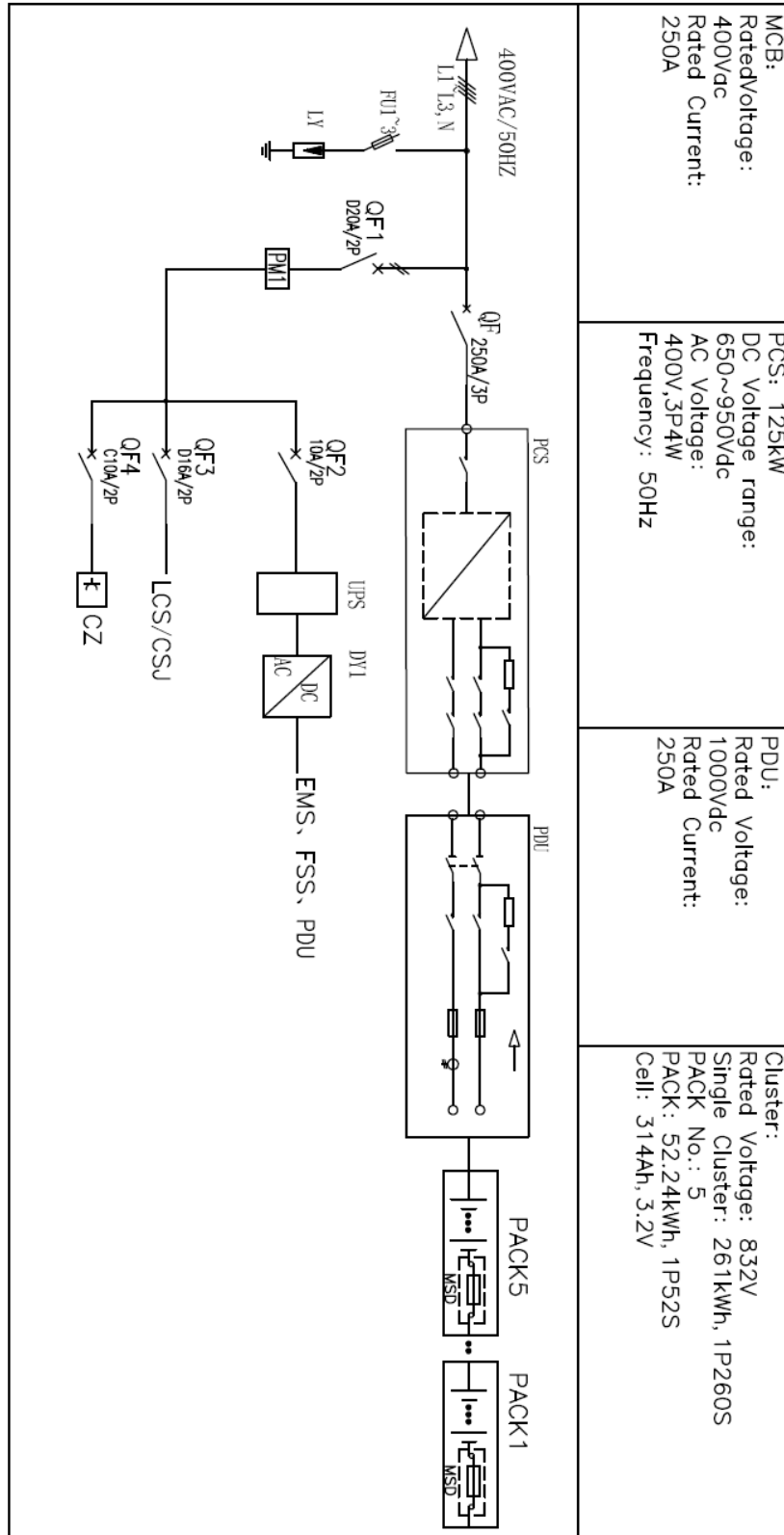

Fig. 2-22 Electrical architecture diagram

2.12.2. Communication Architecture Diagram

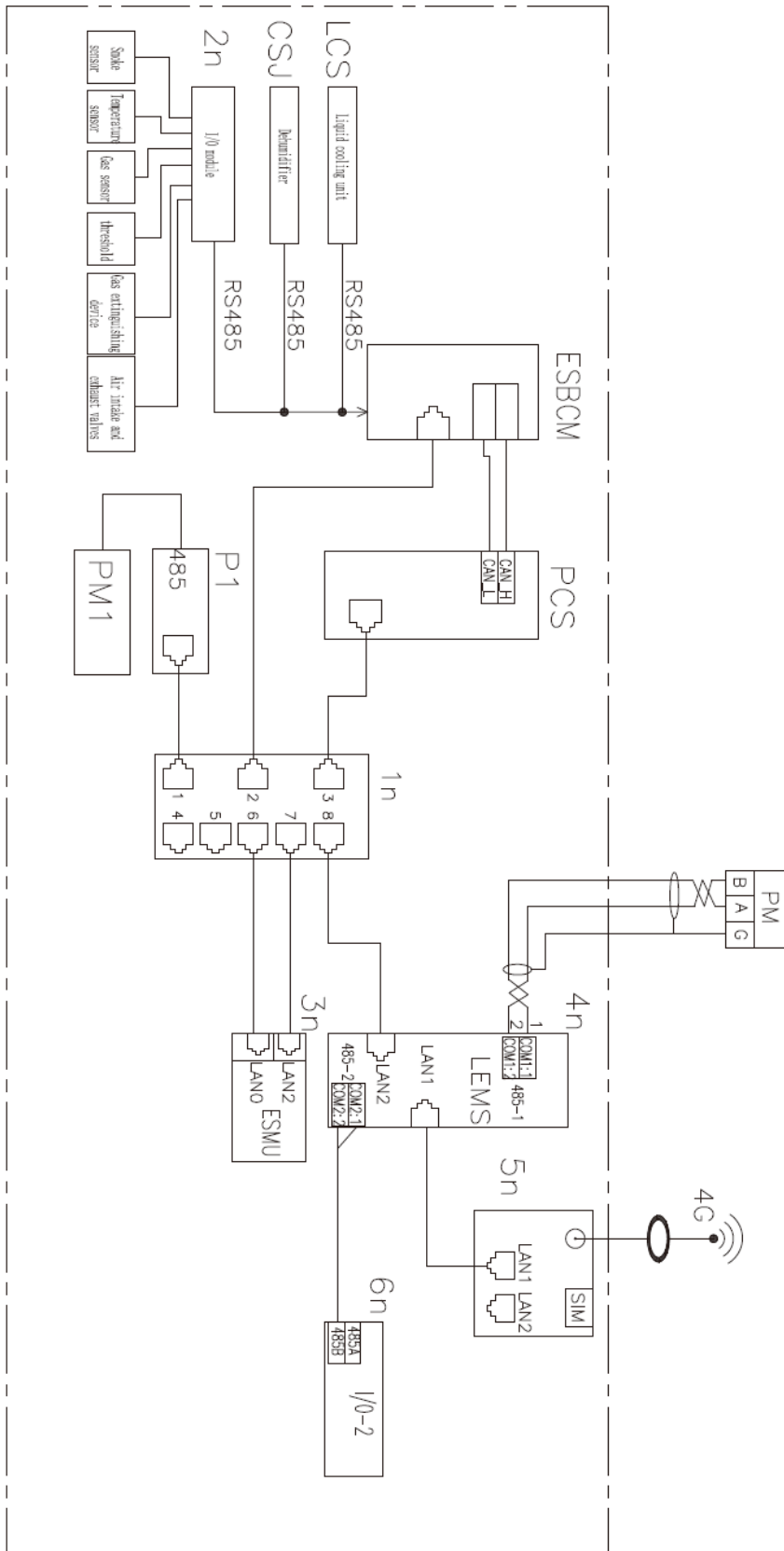

Fig. 2-23 Communication architecture diagram

3. Transportation and Storage





3.1. Transportation

3.1.1. Transportation Requirements

Statement

The internal components of the cabinet has been installed and fixed before leaving the factory, allowing for whole machine transportation.

The equipment is transported to the power station site by a freight company, and the on-site power station management personnel will be contacted in advance to negotiate and arrange specific delivery and unloading. The transportation after delivery and unloading needs to be completed by the on-site power station construction personnel.

	<p>DANGER!</p> <ul style="list-style-type: none"> • During the transportation and handling of the cabinet, it is necessary to comply with the operational safety regulations of the country/region where the project is located. • All equipment used during transportation needs to be maintained. • All personnel involved in handling and securing should receive appropriate training, especially in safety.
	<p>WARNING!</p> <ul style="list-style-type: none"> • Do not move a battery by holding its terminals, bolts, or cables. Otherwise, the battery may be damaged. • Keep batteries in the correct direction during transportation. They must not be placed upside down or tilted, and must be protected against falling down, mechanical impact, rains, snows, and falling into water during transportation.
	<p>NOTICE!</p> <ul style="list-style-type: none"> • Transportation and storage service providers must have the qualifications for dangerous goods operations required by local laws, regulations, and standards. • Rigid box trucks shall be used for transportation and pickup trucks are prohibited.
	<p>NOTICE!</p> <p>Always keep in mind the mechanical parameters (such as dimensions and weight) of the cabinet during transportation and handling.</p>

Safe transportation and handling protocols for energy storage systems

To ensure the safety and integrity of the equipment during logistics and on-site installation, the following guidelines regarding regulatory compliance, packaging, and handling must be strictly observed:

- **Regulatory Compliance and Classification**

In accordance with the UN Recommendations on the Transport of Dangerous Goods (TDG/UN Orange Book), battery systems are classified as Class 9 hazardous materials. Consequently, all shipments must successfully undergo the specific testing protocols outlined in Part III, Subsection 38.3 of the UN Manual of Tests and Criteria. Logistics operations must adhere to applicable international and local regulations, such as the IMDG Code for sea freight, ADR for road transport, and relevant local standards. All packaging, labeling, and declarations must meet the regulatory requirements of the origin, transit, and destination countries.

- **Transportation Mode and Route Selection**

Maritime and road transport via established highways are the recommended modes of shipment. Rail and air transport are generally prohibited unless specific exemptions are granted. Routes should be selected to minimize vibration and shock, avoiding uneven terrain that could compromise the structural integrity of the cargo.

- **Pre-Shipment Inspection and Declaration**

Prior to dispatch, a rigorous inspection is mandatory. The cargo must be accurately declared, and the packaging must be verified as intact, with no signs of leakage, smoke, abnormal odors, or fire hazards. Any unit exhibiting these defects is strictly forbidden from entering the supply chain.

- **Packaging and Moisture Protection**

Robust packaging capable of withstanding transit stresses is required. Measures must be taken to prevent moisture ingress and physical displacement during loading and unloading. Packages must remain upright at all times; tilting or inverting the cargo is prohibited. Dangerous goods labels must be clearly visible and affixed according to safety standards.

- **Segregation and Compatibility**

Unless explicitly permitted by safety regulations, dangerous goods must not be co-loaded with foodstuffs, pharmaceuticals, animal feed, or sharp objects. Where mixed loading of compatible goods is allowed, appropriate segregation must be maintained—typically using a physical barrier of equivalent height and maintaining a minimum clearance (e.g., 0.8 meters) to prevent cross-contamination or damage.

- **Handling of Defective Units**

Defective batteries exhibiting physical damage (scorching, bulging, leakage) require immediate isolation. Terminals must be insulated, and the unit should be secured in an explosion-proof container. Detailed incident logs, including location, time, and symptoms, must accompany the shipment. During transit, such cargo must be routed away from populated areas and critical infrastructure.

- **Storage and Environmental Controls**

Equipment should be stored vertically in a dedicated area, separated from heat sources and protected from precipitation. Stacking must adhere to the manufacturer's specified limits to prevent crushing damage. The storage environment must be monitored, as prolonged exposure to extreme temperatures or humidity can degrade product specifications.

- **Damage Assessment**

If the external packaging is compromised or if the equipment has been subjected to impact or improper orientation, a professional technical assessment is required before installation or commissioning.

Site operations and positioning

- **Equipment Selection and Site Preparation**

Select appropriate lifting machinery, such as cranes or forklifts, based on the specific weight and dimensions of the cabinet. It is imperative that the chosen equipment possesses a load-bearing capacity significantly exceeding the unit's weight to ensure a safety margin. Prior to moving, the path must be cleared of all obstacles, including overhead cables, vegetation, or debris.

- **Environmental Conditions and Safety Perimeters**

Lifting and positioning operations should only be conducted under favorable weather conditions. operations must cease during high winds, heavy rain, or poor visibility. A designated safety zone must be established using warning signs or caution tape to prevent unauthorized personnel from entering the lifting area.

- **Maneuvering on Inclines**

If the equipment must be traversed across sloped surfaces, specialized traction devices or additional anchoring measures are required to prevent slippage or tipping. Extreme caution is advised when navigating gradients.

- **Placement and Foundation Requirements**

The cabinet must be positioned on a solid, level foundation with adequate drainage capabilities. The ground must be free of protrusions that could destabilize the base. During the landing phase, the unit should be lowered gently. dragging, sliding, or forceful pushing of the cabinet is strictly prohibited to prevent structural deformation. The unit should rest solely on its designated base supports.

3.1.2. Crane Lifting

DANGER!

Falling hazard or death.



- During the entire process of lifting the equipment, it is necessary to strictly follow the safety operation procedures of the crane.
- Unauthorized personnel are strictly prohibited from entering the exclusion zone. As shown in Fig. 3-1, the radius must be $R \geq A + 5$ m. Standing or walking under the crane boom or the suspended load is strictly forbidden.
- In case of severe weather conditions, such as heavy rain, thick fog, strong wind, etc., the lifting operation should be stopped.
- Minimum crane lifting capacity: 5 T.

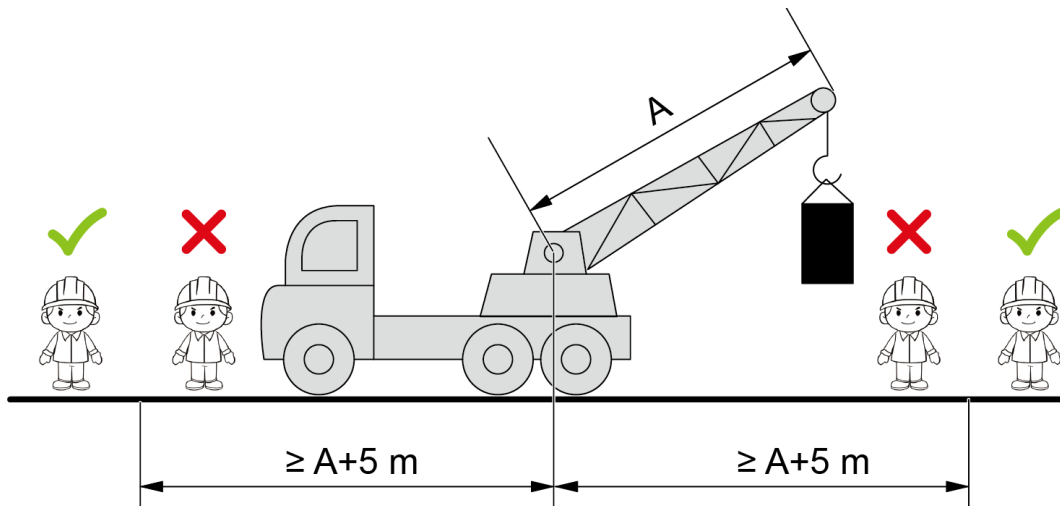

Fig. 3-1 Crane lifting

Crane lifting steps

1. Install the 4 lifting lugs (4), tighten the bolts (1), spring washers (2) and flat washers (3).

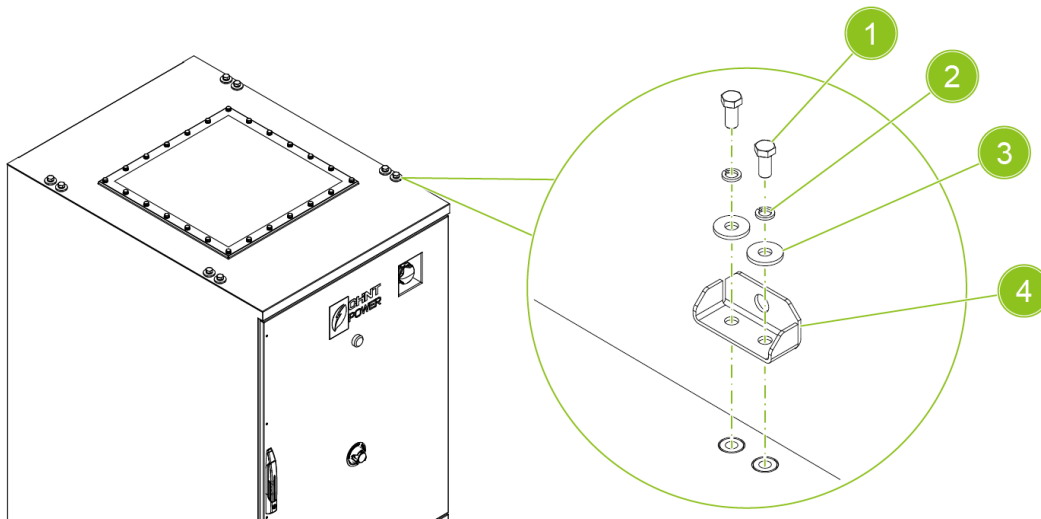

Fig. 3-2 Lifting lug installation

2. Lift the cabinet by lifting belts.



WARNING!

The requirement of lifting belt is shown in the figure below.

Please select the appropriate sling according to the cabinet weight (appr 2.54 T).

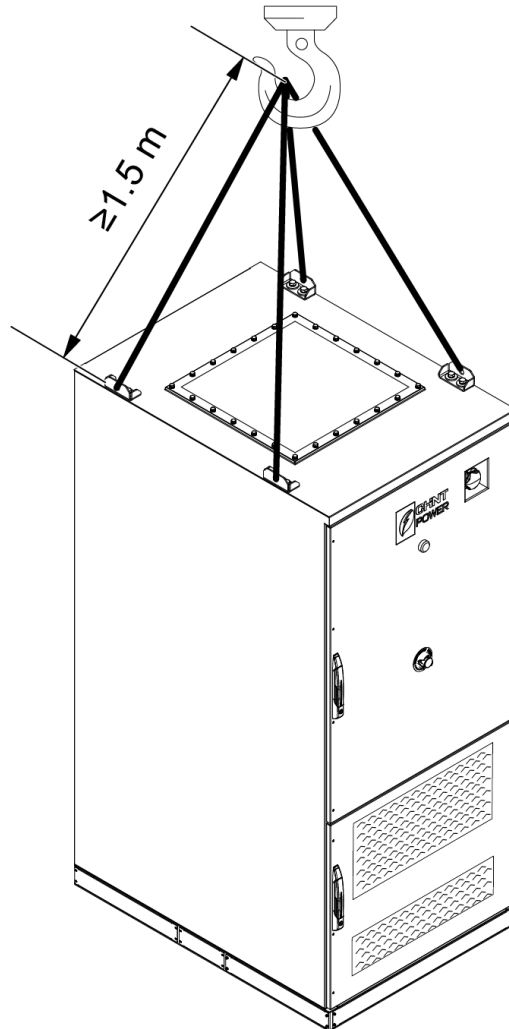

Fig. 3-3 Hoisting

Technical requirements

- Recommended hoisting plan: Slanted hoisting at the hoisting points, with the hoisting tool more than 1 meter away from the top of the cabinet.
- The length of single lifting belt must be longer than 1.5 m, as shown in Fig. 3-3 Hoisting.
- Hoisting speed ≤ 5 meters/minute.
- During hoisting, the cabinet should be well protected, especially at the points where the lifting rope contacts the cabinet.

- The maximum external dimensions of the cabinet: 1000mmx1416mmx2500mm (the height includes the dimensions with the lifting rings).
- The estimated total weight of the cabinet: 2535±50kg.
- The lifting equipment and ropes should be considered with sufficient safety factors by a professional hoisting company.

3.1.3. Forklift Handling



DANGER!

- During forklift operation, no one is allowed to stand around the forklift.
- Before operating the forklift, please use a safety rope (1) to secure the equipment to the forklift arm.
- Only qualified personnel are allowed to operate the forklift.

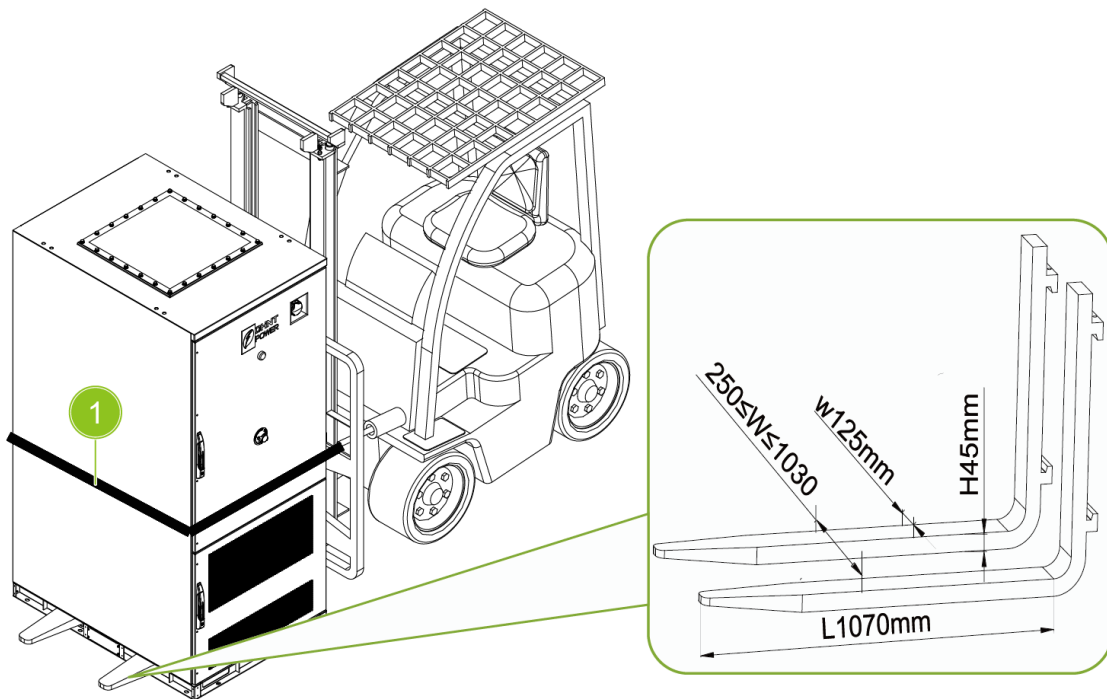



Fig. 3-4 Forklift

3.2. Storage

	<p>IMPORTANT!</p> <p>If the equipment is not put into use immediately upon arrival, please store the equipment in accordance with the following requirements.</p> <p>Damage to the inverter caused by improper storage is not covered by the warranty.</p>
---	---

3.2.1. System Storage Requirements

Item	Requirement
Package	Do not store without the original packaging. If the package has been opened, it must be put back into the original packaging and sealed with tape.
Safe storage environment	Temperature -30°C~60°C; humidity ≤ 95%RH(without condensation).
Recommended storage environment	Temperature: 0~35°C; humidity ≤ 85%RH(without condensation)
Chemical protection	Keep away from corrosive substances such as acids and alkalis; the air must not contain flammable gases.
Storage location	The system should be stored in a dry warehouse to avoid exposure and rain. No harmful gases, flammable or explosive products and corrosive chemicals are allowed in the warehouse. Keep away from mechanical impact, heavy pressure and strong magnetic field. Avoid direct sunlight and the distance to heat source should be more than 2 m away.

Orientation

Strictly follow the "This Side Up" arrow indicators on the packaging. Tilting or inverting is strictly prohibited.

Stacking limit

Do not exceed the maximum stacking layers indicated on the outer carton.

Safety warning

Handle with care during stacking to prevent equipment tipping, which could cause personal injury or equipment damage.

Temporary outdoor storage

Stacking on pallets is strictly prohibited. Must be covered with waterproof tarps to prevent erosion from rain or standing water.

3.2.2. Battery Storage Requirement

- SOC range of battery storage: 30%~50%., avoid long-term storage of batteries below 15% SOC. If the battery is not used for a long time, it is necessary to cut off the power-consuming equipment in time.
- Perform battery maintenance on the system every six months to prevent battery damage.
- The battery PACK may be recharged up to 3 times during the whole system storage period. If no recharge is performed, the storage period must not exceed 2 years. If it exceeds 2 years, customers need to report to CPS or CPS authorized service providers for a professional inspection. Only after confirming that the performance and safety status of the battery PACK meet the standards can the warranty be reactivated. If customers don't report or the inspection is unqualified, the warranty will be lost.
- Before the first usage of long-time unused system, the battery system must be fully charged at least once to activate the battery system in order to recover the battery performance to the best condition.
- Safe storage environment: Temperature -30°C~60°C; humidity ≤95%RH(without condensation).
- Recommended storage environment: Temperature: 0~35°C; humidity ≤85%RH(without condensation)

3.2.3. Periodic Maintenance and Activation

Regular inspection

- It is recommended to inspect the outer packaging of the equipment every three months. If the packaging is damaged (such as due to moisture or insect damage), the packaging material must be replaced in a timely manner.

Activation after long time storage

- If the equipment has been stored for more than 1 year, you need to contact CHINT or distributor to inspect and test the equipment first.

4. Installation

	<p>NOTICE!</p> <p>Do not open the cabinet door when the humidity is high (relative humidity \geq 80% continuously), for example, on rainy days. If the cabinet door is open for 0.5 hour or longer when the humidity is high, manually perform forced dehumidification. Otherwise, the equipment may fail or the microgrid may collapse.</p>
---	--

	<p>IMPORTANT!</p> <p>All personnel involved in installation activities should receive training on the CHINT industrial-commercial integrated cabinet system and possess relevant experience. Individuals must meet all the pre-requisites for training and must complete the system training. These personnel include:</p> <ul style="list-style-type: none"> • Service personnel who carry out any installation work within the scope of the owner's work as specified in this document. • Owner representatives who carry out any installation work within the scope of the owner's work as determined in this document. • Before installation, ensure that the cabinet is firmly fixed and the center of gravity is balanced. Otherwise, the cabinet may tip over or fall, which could cause personal injury and equipment damage.
---	---

4.1. Installation Requirements

4.1.1. Site Selection Requirements

	<p>NOTICE!</p> <p>The location selection of equipment and fire safety must comply with local laws and regulations. Reference standards include but are not limited to NFPA 855 "Standard for Installation of Stationary Energy Storage Systems"</p>
---	--

Site requirements

- Do not install the equipment in environments prone to fire or explosion. Fire-fighting facilities must be safe, available and compliant.
- The installation site must have good ventilation and be equipped with interfaces for the water fire protection system.
- Ensure that the installation location is higher than the historical highest water level in the area. Do not deploy it in areas that may be flooded by water.
- The equipment should be installed at a distance of 30 meters away from third-party wireless communication facilities.

4.1.2. Clearance Requirements



NOTICE!

- Under any circumstances, the entire cabinet is not allowed to be stacked.
- Without prior assessment by our company, do not install any additional devices on the top of the equipment.
- The reserved distance has taken into account the tools required for equipment replacement inside the cabinet as well as the thermal management requirements. In all scenarios, the reserved distance on both sides of the equipment needs to be $\geq 400\text{mm}$.

Layout plan 1

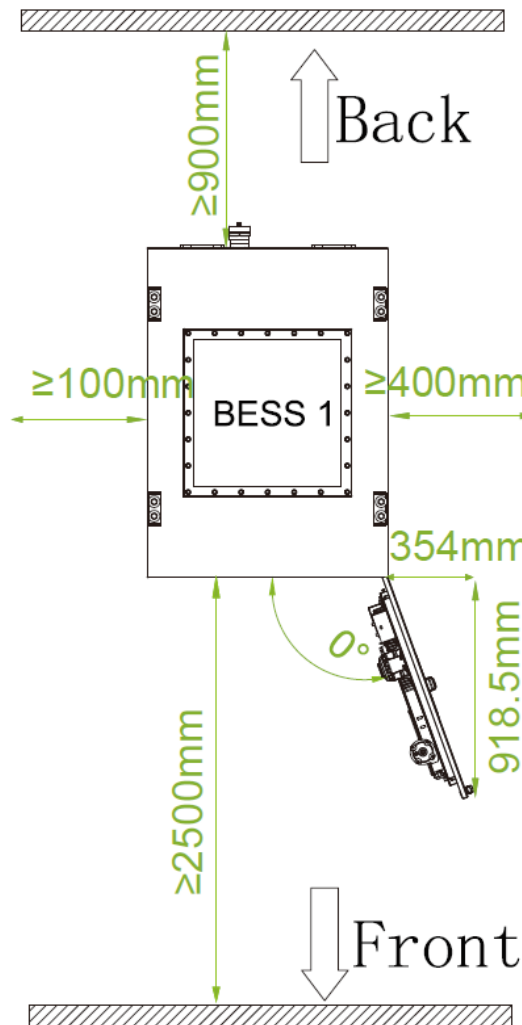

Fig. 4-1 Single cabinet

Layout plan 2

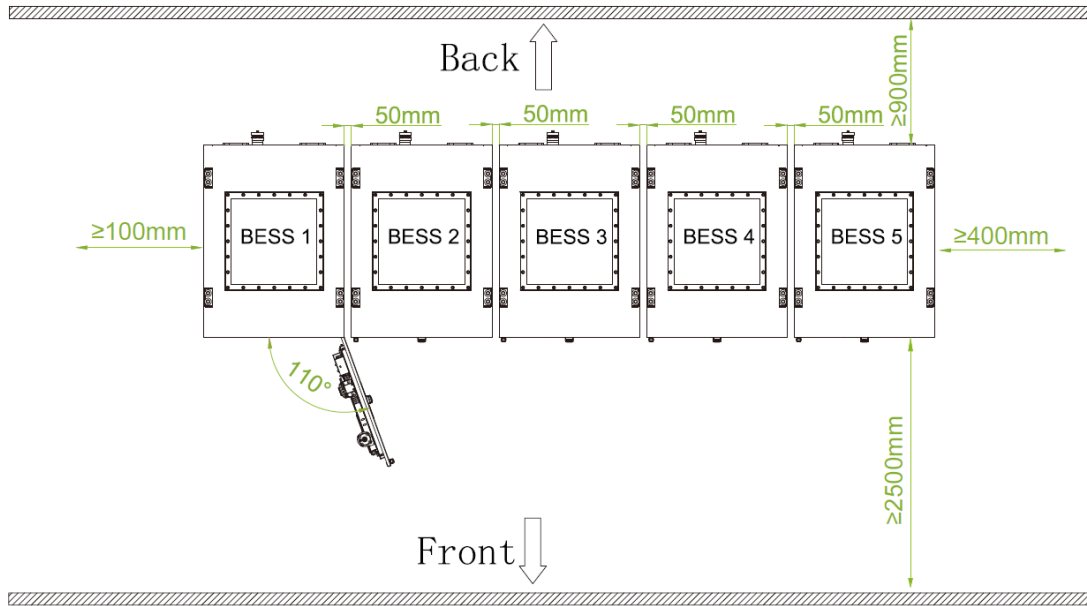

Fig. 4-2 Multiple cabinets – In One Line

Layout plan 3

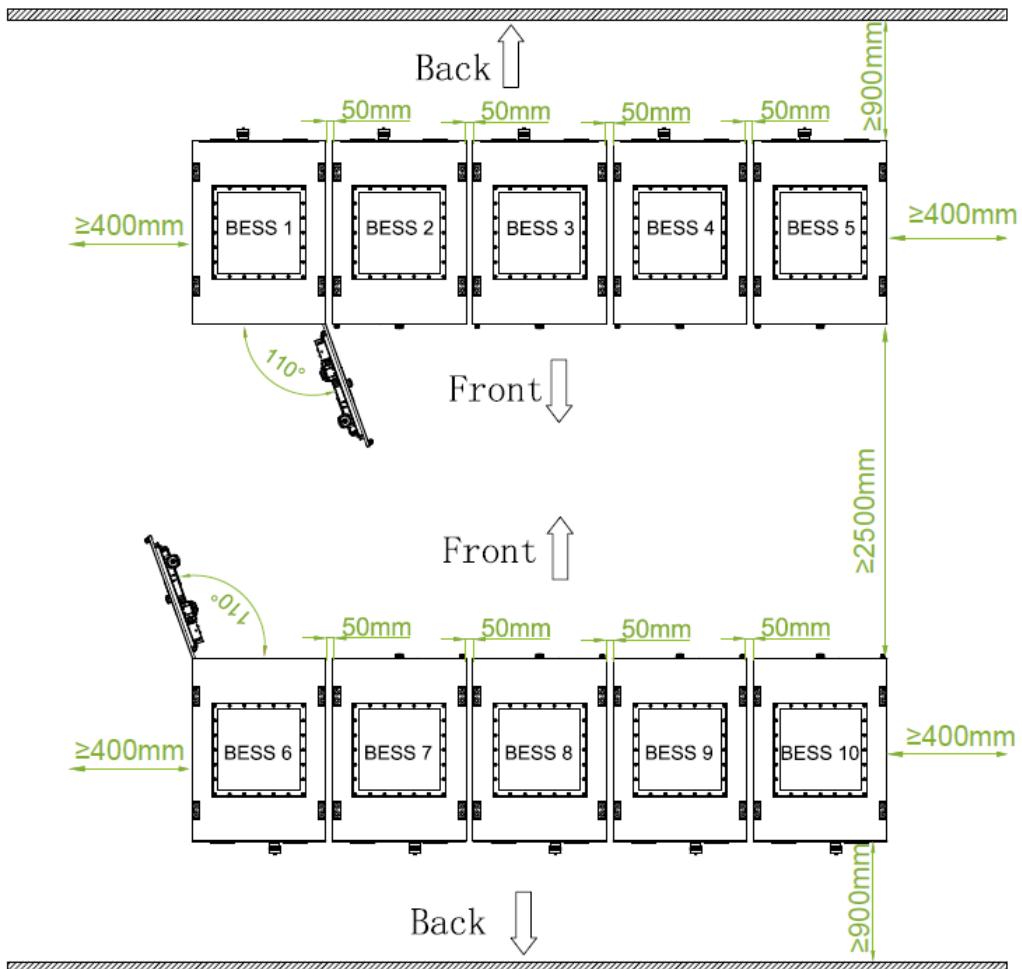

Fig. 4-3 Multiple cabinets – Front to Front

Layout plan 4

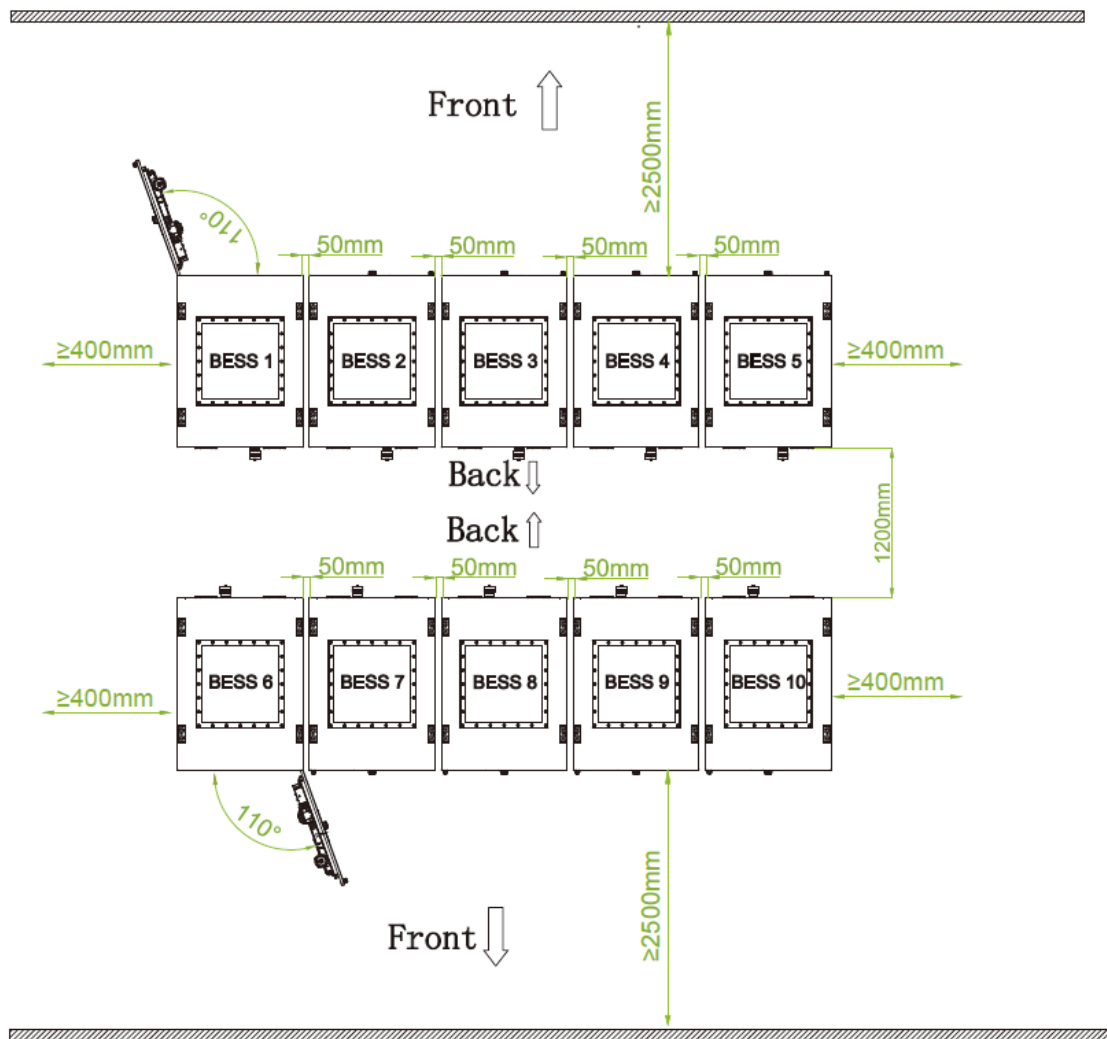

Fig. 4-4 Multiple cabinets – Back to Back

4.1.3. Foundation Requirements

- The equipment must be installed on a structure with a cement foundation with flame-retardant materials on the surface or a structure supported by channel steel. It is essential to ensure that the foundation is flat, solid, safe, reliable, and has sufficient load-bearing capacity. Any depression or tilting on the foundation surface is strictly prohibited.
- The equipment can be welded to the foundation steel plate or connected by other methods with equivalent firmness.
- When constructing the foundation, make sure to leave drainage holes. The position of the equipment drainage holes can be referred to Fig. 4-7 Prepare cable holes and drain holes.
- The number of support points and the load-bearing capacity of the support units for the equipment on the foundation are shown in the following figure:

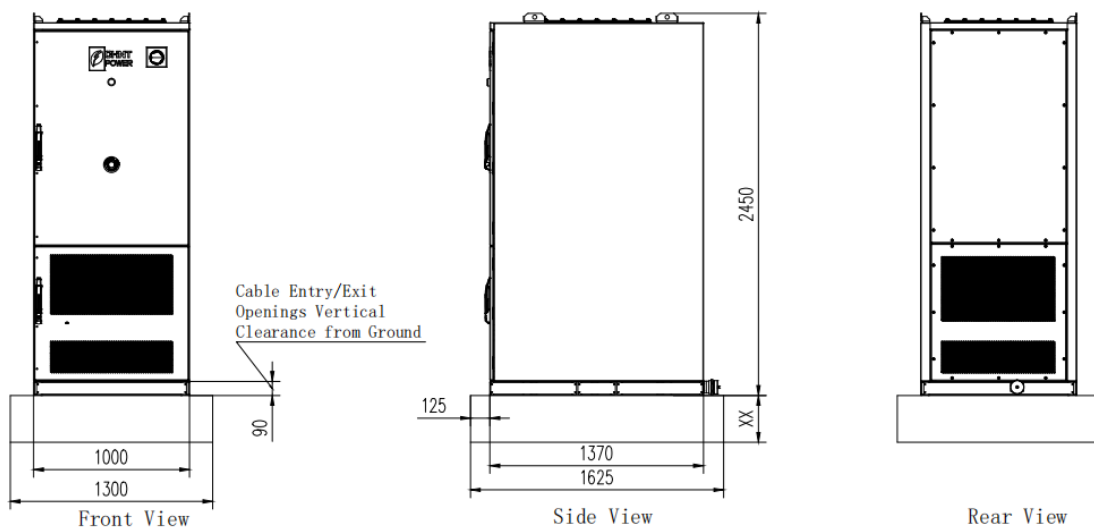

Fig. 4-5 Foundation overview

Technical notes

- This drawing is for reference only and is intended to be used as a reference for customers to design the foundation. It cannot be used as a foundation construction drawing.
- The foundation reference plane of the equipment needs to be above the horizon and higher than the maximum precipitation height at the project site.
- The maximum total weight of the equipment is approximately 3 tons. It is recommended that the minimum support weight of the foundation exceeds twice the total weight of the equipment.
- The flatness tolerance of the entire foundation shall be controlled within $\pm 2\text{mm}$; if the foundation flatness exceeds this requirement, after the equipment is fully loaded with battery PACKs, it may cause the cabinet door to fail to open and close normally, or even result in permanent deformation that cannot be repaired. Please strictly follow this requirement.

4.2. System Unpacking Inspection

4.2.1. Precautions

Statements

Before unpacking, to prevent the equipment from tipping over, please secure the box containing the equipment to the forklift with ropes before moving. Handle the equipment with care, as impact or dropping may cause damage.

During the packaging removal process, pay attention to avoid scratching the equipment.

During the equipment packaging removal process, ensure the equipment remains stable and balanced, and take appropriate protective measures.

If the installation environment is poor, such as the presence of dust, corrosive gases, splashing water, and drastic temperature differences, etc., do not remove the packaging. If the packaging has been removed, please take dust-proof and anti-condensation measures (such as using dust covers, plastic films, or fabric covers) to avoid condensation or dust accumulation leading to corrosion and failure inside the battery.

1. Move cabinet to installation site
2. Unpack its outer film, styrofoam and package.
3. Remove the 24 fastening bolts and take off 6 seal plates.
4. Remove the 12 fastening bolts to disassemble cabinet from pallet.

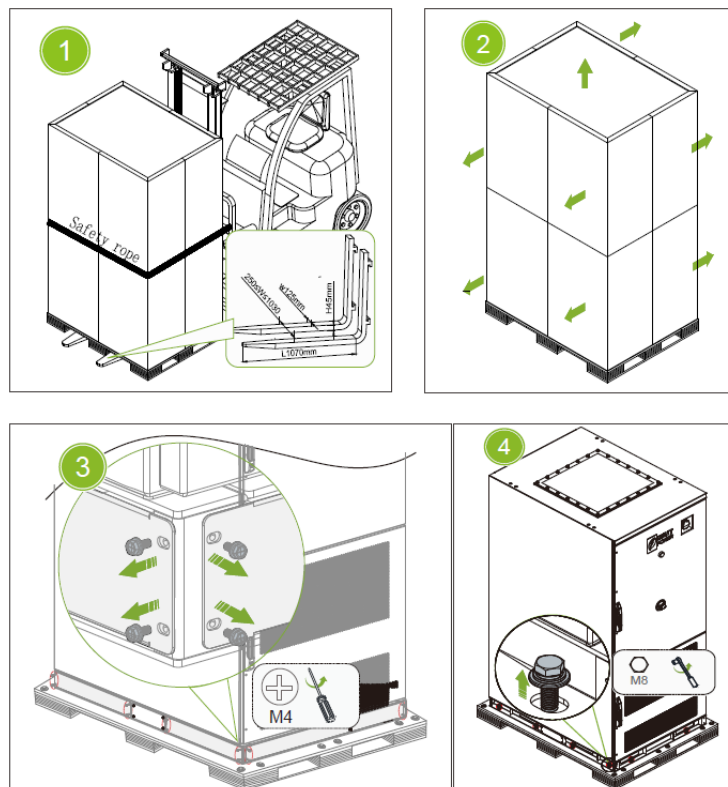

Fig. 4-6 System unpacking

Table 4-1 Check after unpacking

Check item	Criteria	Precautions
Check the outer packaging before unpacking	<p>Check whether the outer packaging is damaged, such as holes, cracks or other signs of internal damage.</p> <p>If any damage is found, do not unpack the equipment and contact you vendor as soon as possible.</p>	You are advised to remove the outer packaging within 24 hours before installing the equipment.
	<p>Check the equipment model, do not unpack the equipment and contact you vendor as soon as possible.</p>	None
	<p>Check whether there is a tilt indicator label on the outer packaging.</p> <p>If the tilt indicator turns red or any signs of water ingress and sealing damage are found, stop unpacking, check for causes immediately and contact your vendor as soon as possible.</p>	None
Checking deliverables after unpacking	<p>Check whether the deliverables are complete, and whether there is any obvious external damage.</p> <p>If any item is missing or damaged, contact your vendor.</p>	For details about the quantity of deliverables, please refer to 4.2.2 Scope of Delivery.
Check cables after unpacking	<p>After unpacking, check whether the cables inside the equipment are damaged.</p> <p>If any damage is found, do not unpack the equipment and contact you vendor as soon as possible.</p>	None

4.2.2. Scope of Delivery

Item	Name	Qty	Remark
1	Outdoor cabinet	1	
2	System drawings	2	Circuit diagram Wiring diagram
3	Door lock key	4	/
4	Lifting lug	4	/
5	Water inlet joint	1	/
6	Certificate of conformity	1	/
7	DB9 connector	3	/
8	MSD locking plug	5	/

Item	Name	Qty	Remark
9	DT copper terminal	6	/
10	RJ45 connector	4	/
11	Fireproof putty	1	/
12	Expansion bolt	12	M12x110

4.2.3. Safety Inspection

Requirements

- The equipment involves high voltage and strong currents. Operation by anyone without professional supervision is prohibited. Operators must enhance their sense of safety and vigilance and always wear personal protective equipment (PPE), especially insulating gloves. The equipment must not be turned off or opened without authorization while it is running. In the event of an accident, quickly disconnect the main circuit breaker and ensure an immediate response is made to the responsible personnel.
- Pay attention to the weather conditions and enhance safety awareness during rainy days. Check the working environment where the equipment is located to ensure it is clean and tidy. Inspect whether the fire safety equipment is well-maintained and whether the escape routes are unobstructed.
- Ensure that the equipment has no insulation faults, and the insulation resistance of all busbars to ground is not less than 2.5MΩ as specified by national standards.
- Check the connection points of all wires to ensure they are secure. Specifically, refer to national standards and visually inspect the electrical safety clearance between the electrodes of the power lines, as detailed in the table below:

Rated line voltage / kV	Electrical clearance/mm	Creepage distance/ram
0.38 (0.4)	8	12 (max)
0.66 (0.69)	10	20 (max)
3 (3.5)	36	75 (max)

NOTICE!

For more information, refer to the standard *UL 1973-2022*.

4.3. ESS Installation



NOTICE!

Before installation, please make sure the foundation is finished.



WARNING!

During installation, please use all the auxiliary equipments as required.

Step 1. Prepare cable holes and drain holes on foundation.

1. Prepare AC cable hole.
2. Prepare grounding and COM cable hole
3. Prepare cabinet dewatering holes.
4. Prepare dehumidifier dewatering hole (lower one) and drain hole (upper one).
5. Prepare dewatering hole.

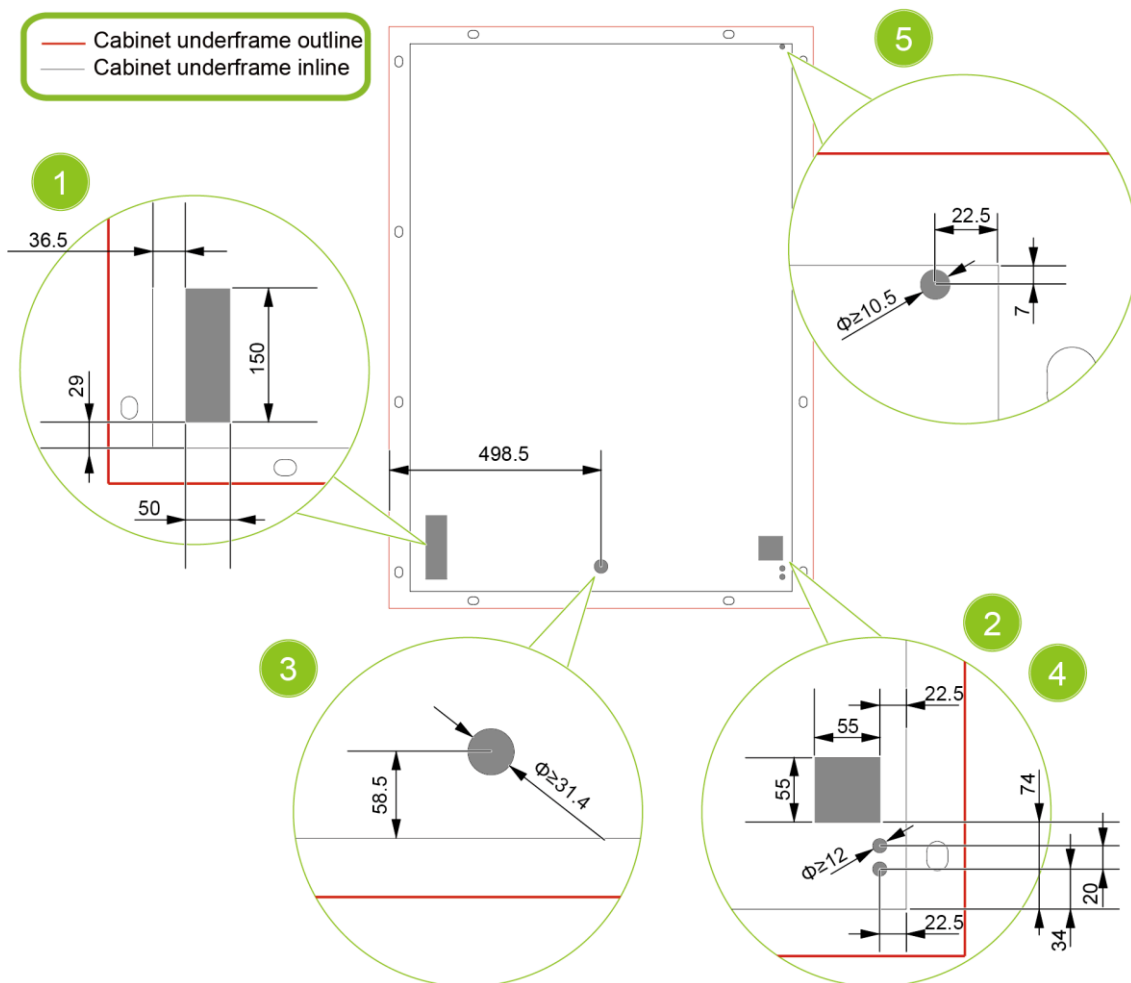

Fig. 4-7 Prepare cable holes and drain holes

Step 2. lift or hoist the cabinet.



CAUTION!

Position forklift arms evenly on both sides of vertical central lines of the cabinet or keep crane hooks directly above the top center of the cabinet, to prevent the cabinet from tilting or falling.

- Option 1: Lift by forklift (load-bearing capacity ≥ 5 t)

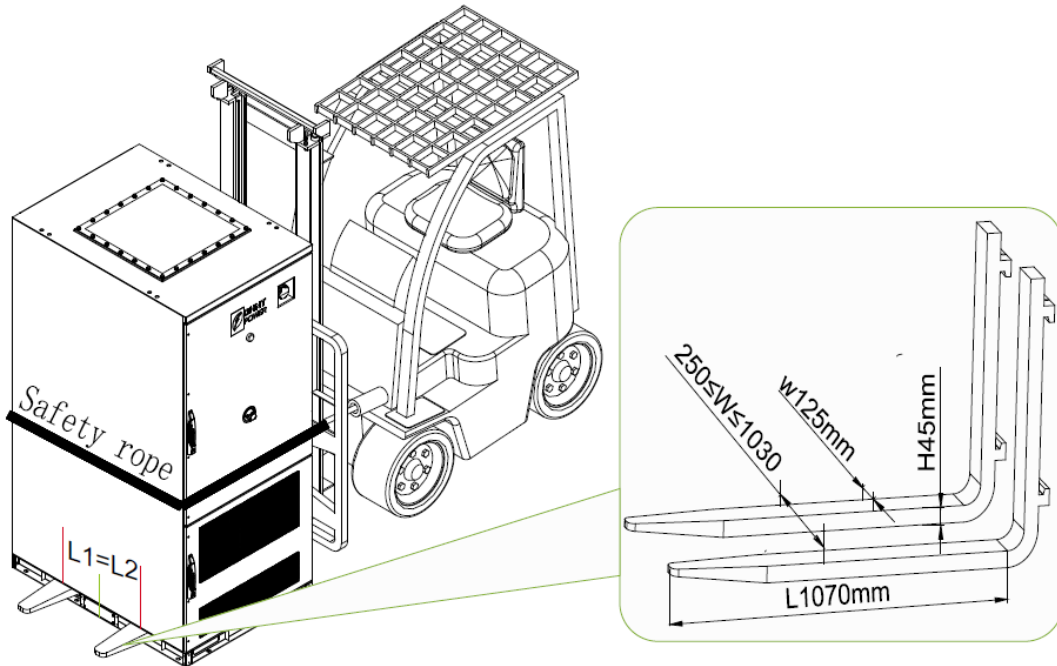

Fig. 4-8 Forklift

- Option 2: Install lifting lugs provided and hoist by crane (hoist capacity ≥ 5 t).

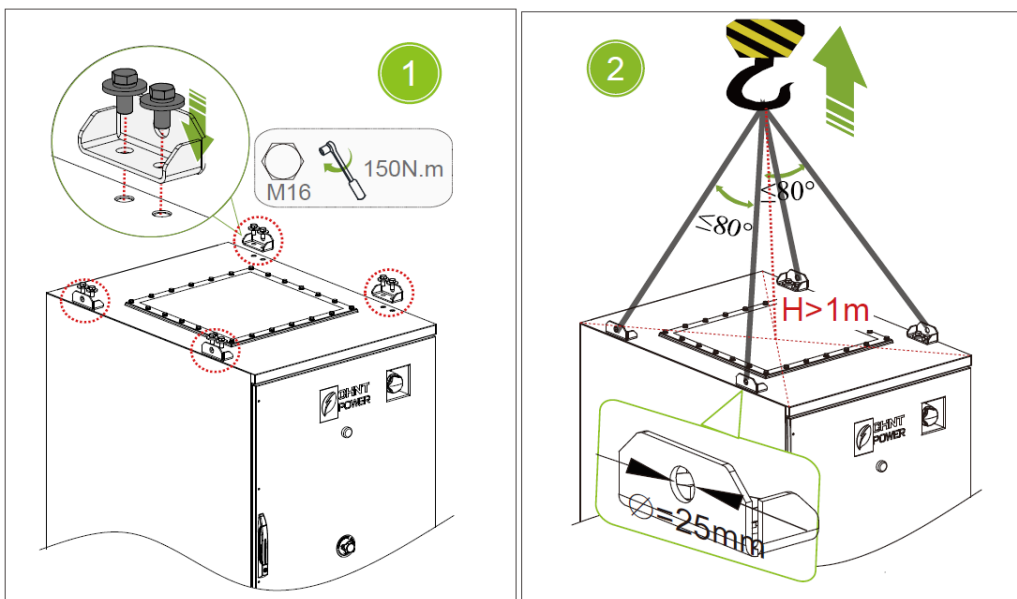

Fig. 4-9 Hoist

- Option 3: Ensure all cabinet supports are fully seated on the foundation. No supports shall be left unsupported or suspended.

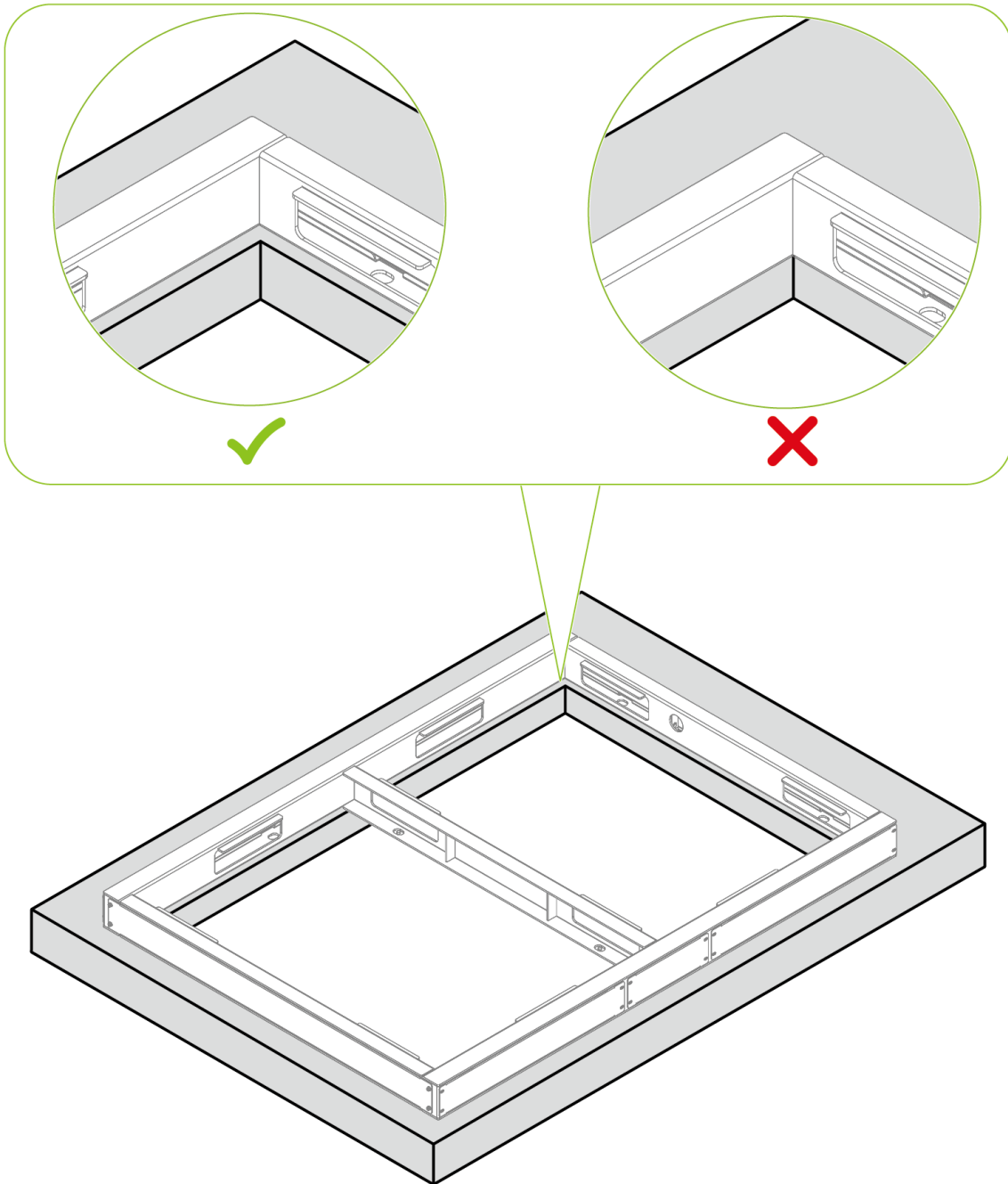

Fig. 4-10 Cabinet placing requirement

Step 3. Fasten cabinet onto foundation

1. Align all cabinet installation holes with expansion bolts on foundation.
2. Tighten gaskets and nuts to fasten cabinet.
3. Recover seal plate.

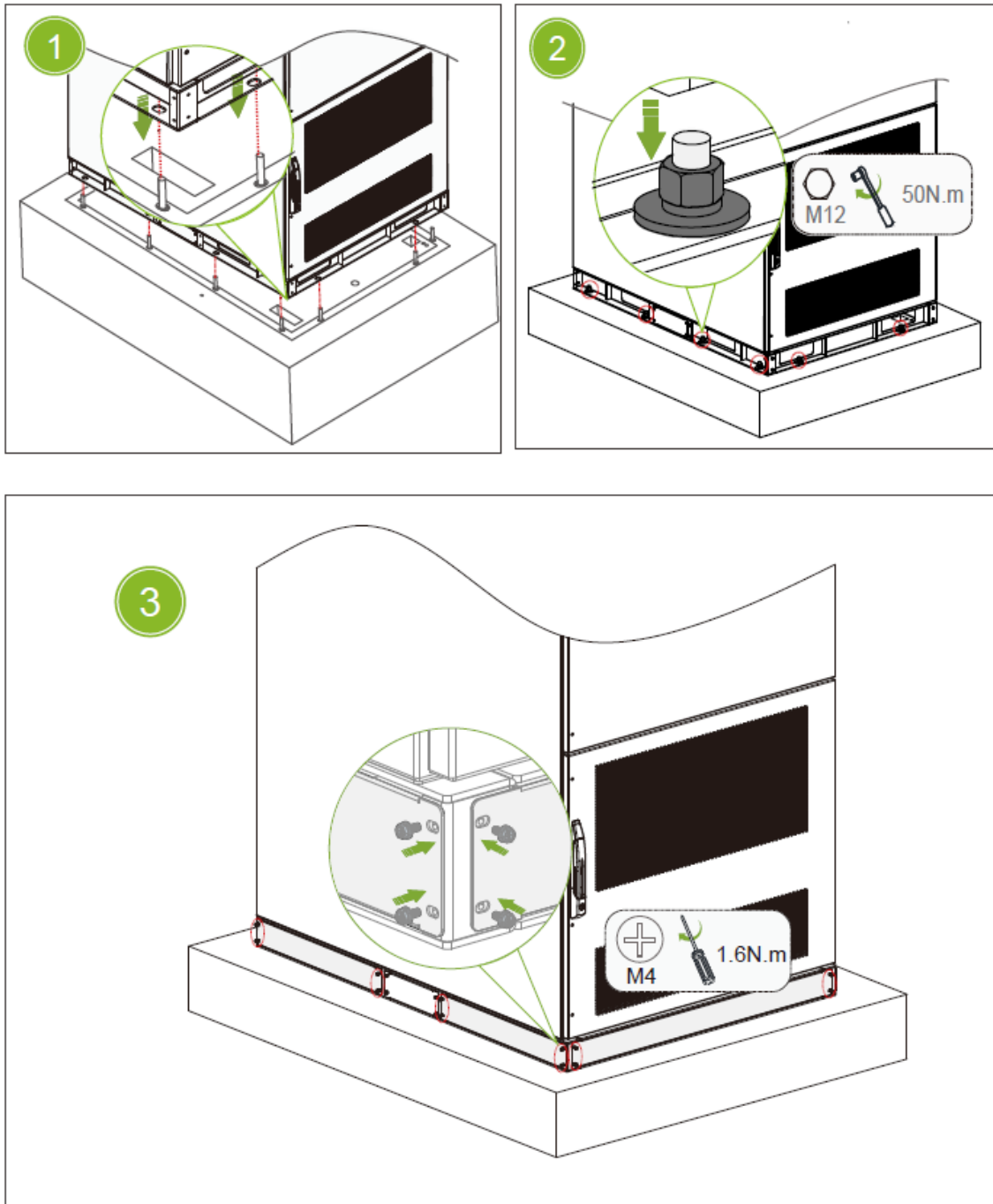

Fig. 4-11 Fasten the cabinet onto the foundation

Step 4. Install the water pipe connector

Tighten the reducing adapter (1) and the quick connector (2).

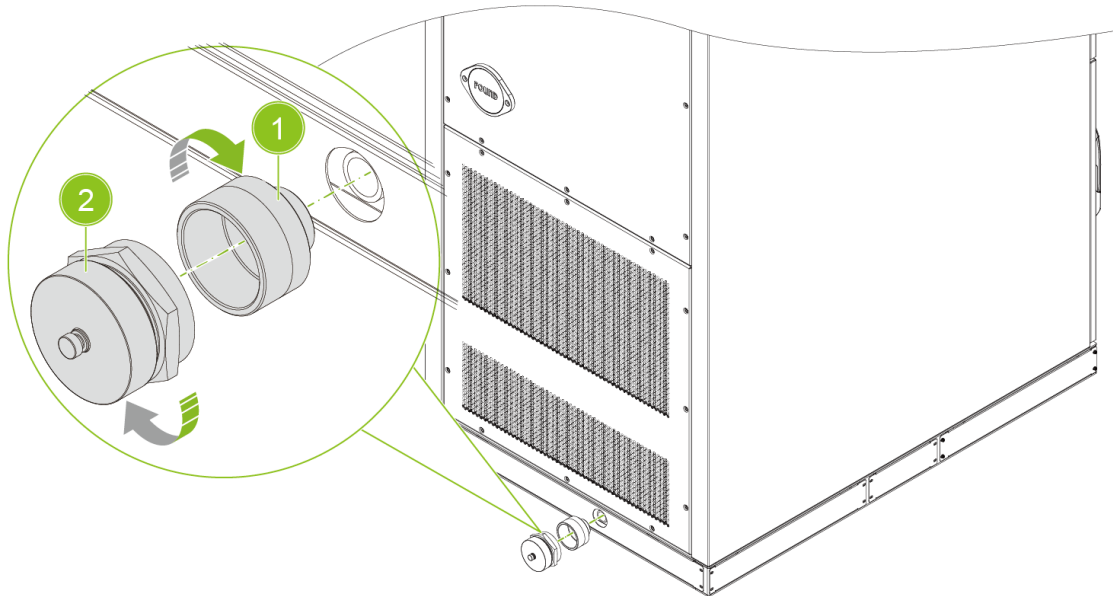





Fig. 4-12 Install the water pipe connector

5. Cable Connection

	<p>WARNING!</p> <ul style="list-style-type: none"> • Do not wear watches, rings, jewelry or other metal items. • Before entering the construction site, correctly wear a helmet to protect your head. Also, wear insulating gloves and safety shoes. • Use tools with good insulation to prevent accidental electric shock or short circuit.
---	--

	<p>IMPORTANT!</p> <p>Before cable connection:</p> <ul style="list-style-type: none"> • Read the 1.3 Electrical Safety Principles carefully. • Prepare PPE and tools by referring to Annex 1 & 2.
---	---

	<p>IMPORTANT!</p> <p>To facilitate on-site cable connection, the wiring between the internal devices of the equipment has all been completed before leaving the factory. You only need to finish the following connections between external equipment and the equipment:</p> <ul style="list-style-type: none"> • Grounding • AC power line wiring • Communication wiring.
---	--

5.1. Cable Specifications

	<p>NOTICE!</p> <p>The selected cable's diameter should adhere to applicable regional cable specifications. Key considerations in choosing an appropriate cable encompass its current-carrying capacity, insulation and construction type, installation method (e.g., conduit, tray, or direct burial), surrounding environmental temperature, and the allowable voltage drop across the circuit.</p>
---	---

Table 5-1 Cable specifications

Name	Cable type	Conductor cross sectional area
Grounding cable	Cable specialized for outdoor use	35 mm ²
L1/L2/L3/N cable	Outdoor four/five-core copper wires	> 70 mm ² (single phase)
COM cable	CAT-5e	N/A

5.2. Grounding Connection

Step 1. Crimp the cable

1. Prepare the grounding terminal (TLK35-8 is recommended).

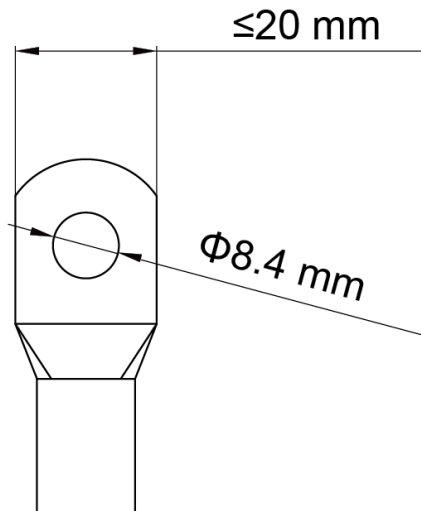

Fig. 5-1 Grounding terminal

2. Strip off wire and prepare heat shrink tubing. The specific dimensions can be seen in the following picture.

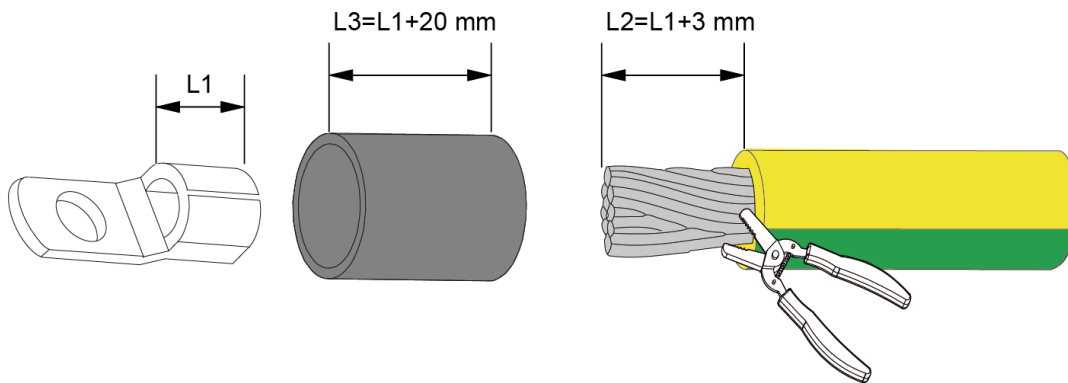

Fig. 5-2 Strip wire and prepare heat shrink tubing

3. Install the heat shrink tubing and crimp wire on the terminal.

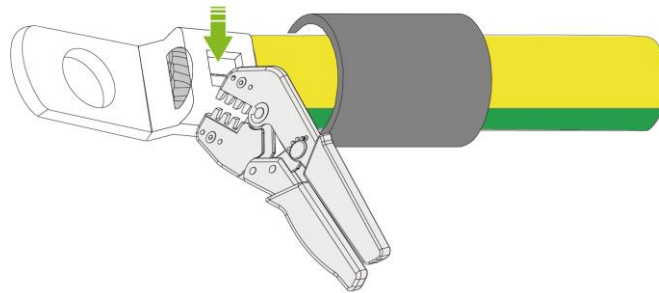

Fig. 5-3 Crimp wire on the terminal

4. Seal heat shrink tubing by using hot air gun.

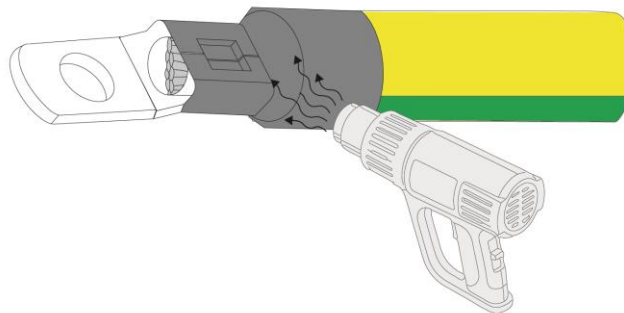

Fig. 5-4 Seal the heat shrink tubing

Step 2. Open and support cabinet door

Open the upper and lower cabinet doors by keys provided and move the free end of two support rods to the fastening holes of cabinet doors.

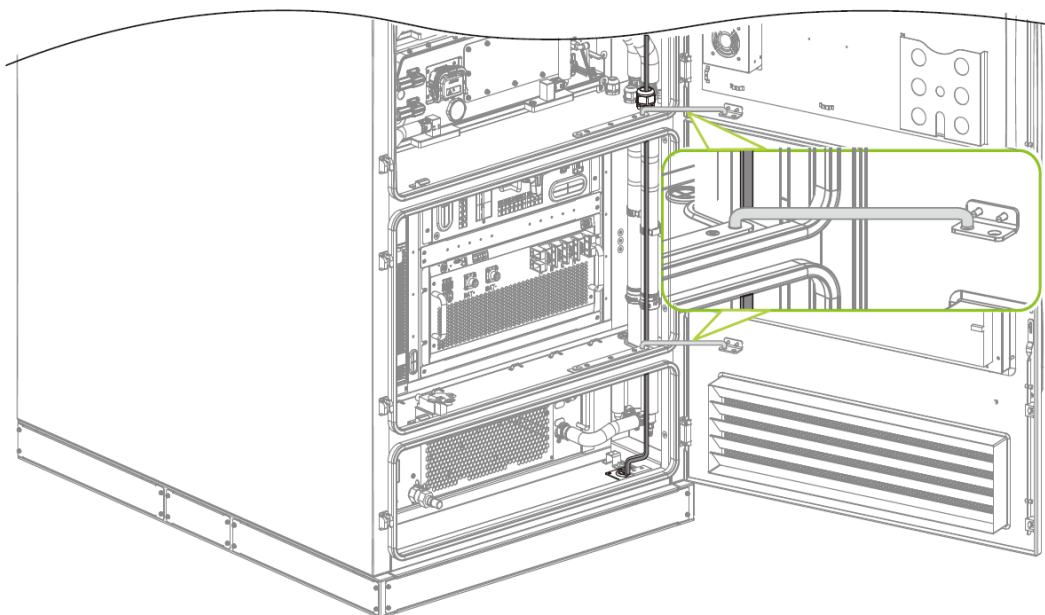

Fig. 5-5 Open and support the cabinet door

Step 3. Connect the grounding cable.

Pass grounding cable through the cable hole and tighten it onto the grounding busbar.

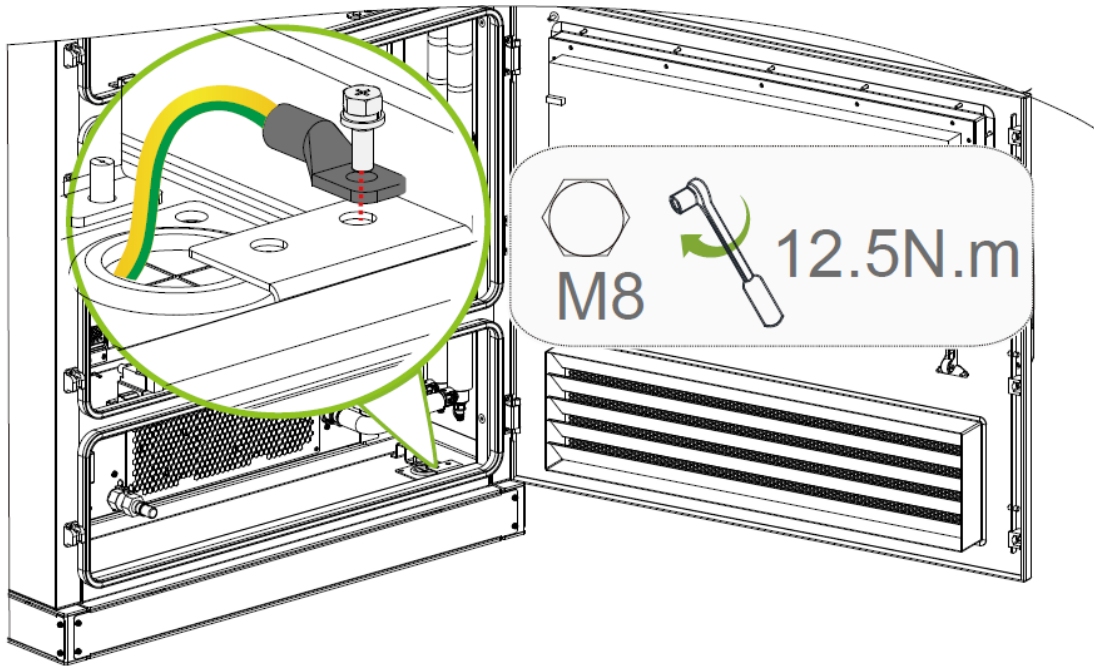

Fig. 5-6 Connect the grounding cable

5.3. AC Cable Connection

5.3.1. Earthing System



NOTICE!

The standard ESS supports TN-S, TN-C, TN-C-S and TT systems.

The IT system needs to be specialized customized.

For the TN-S, TN-C, TN-C-S and TT system, the neutral wire of the ESS must be connected to the power grid.

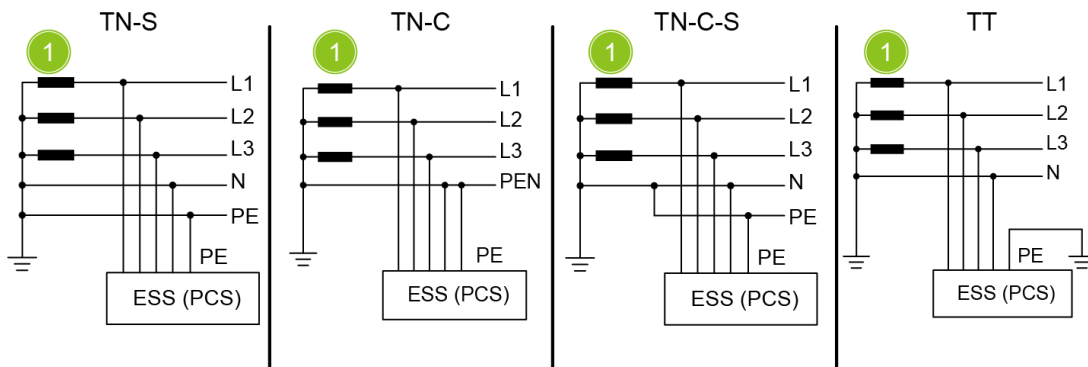

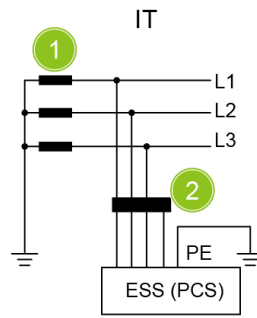

Fig. 5-7 Earthing system

1. Transformer

2. Isolation transformer (prepared by customer)

5.3.2. Connection Steps

Here we take four-core wires connection method for an example. For five-core wires, connect PE wire to the grounding terminal near the AC busba.

Step 1. Crimp the cable.

1. Strip off the wire and prepare the heat shrink tubing.

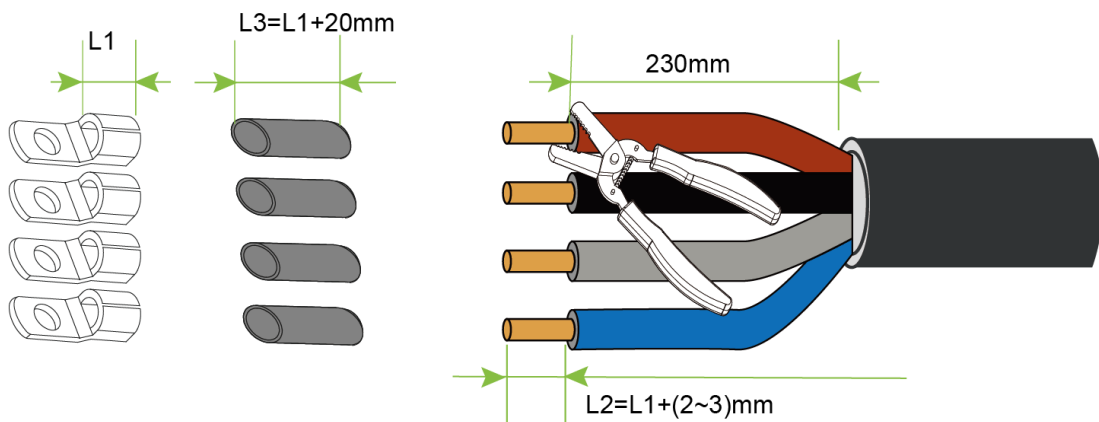

Fig. 5-8 Strip wire

2. Install heat shrink tubing and crimp wires on DT terminals (provided).

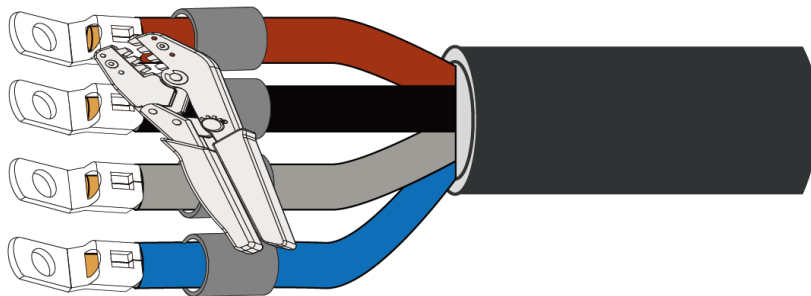

Fig. 5-9 Install the DT terminals

3. Seal heat shrink tubing by hot air gun.

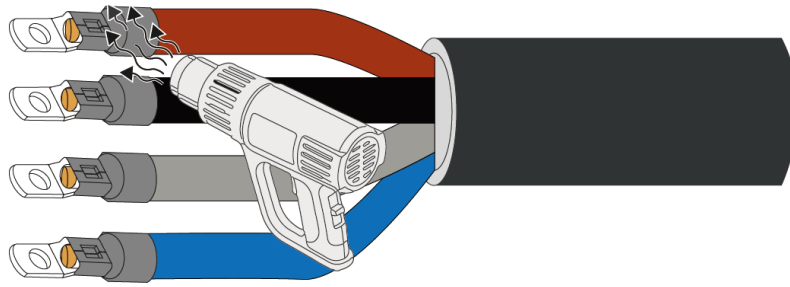

Fig. 5-10 Seal the heat shrink tubing

Step 2. Connect the cable.

1. Pass the AC cable through the cable hole in order.
2. Tighten the nuts to fasten AC wires onto the AC busbar.
3. Bundle wires onto wire ferrules one by one with cable ties.

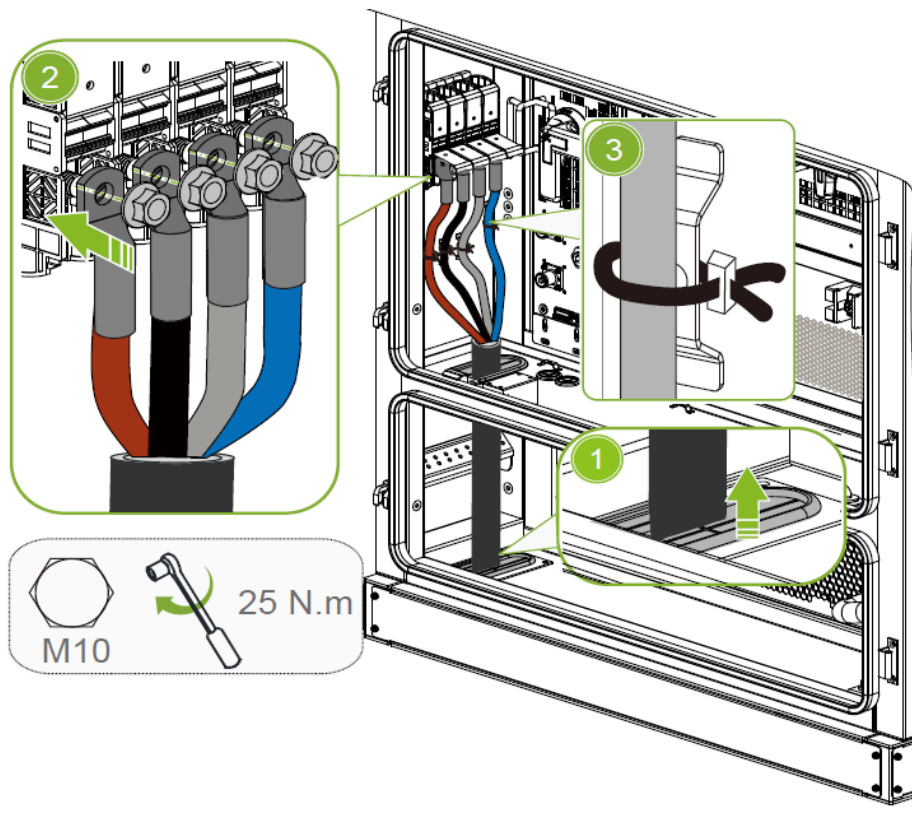

Fig. 5-11 Connect the cable

5.4. Communication Connection

Step 1. Pass cable into the cabinet.

1. Pass cables through the cable hole.
2. Loosen the gland and pass the cable through the gland.

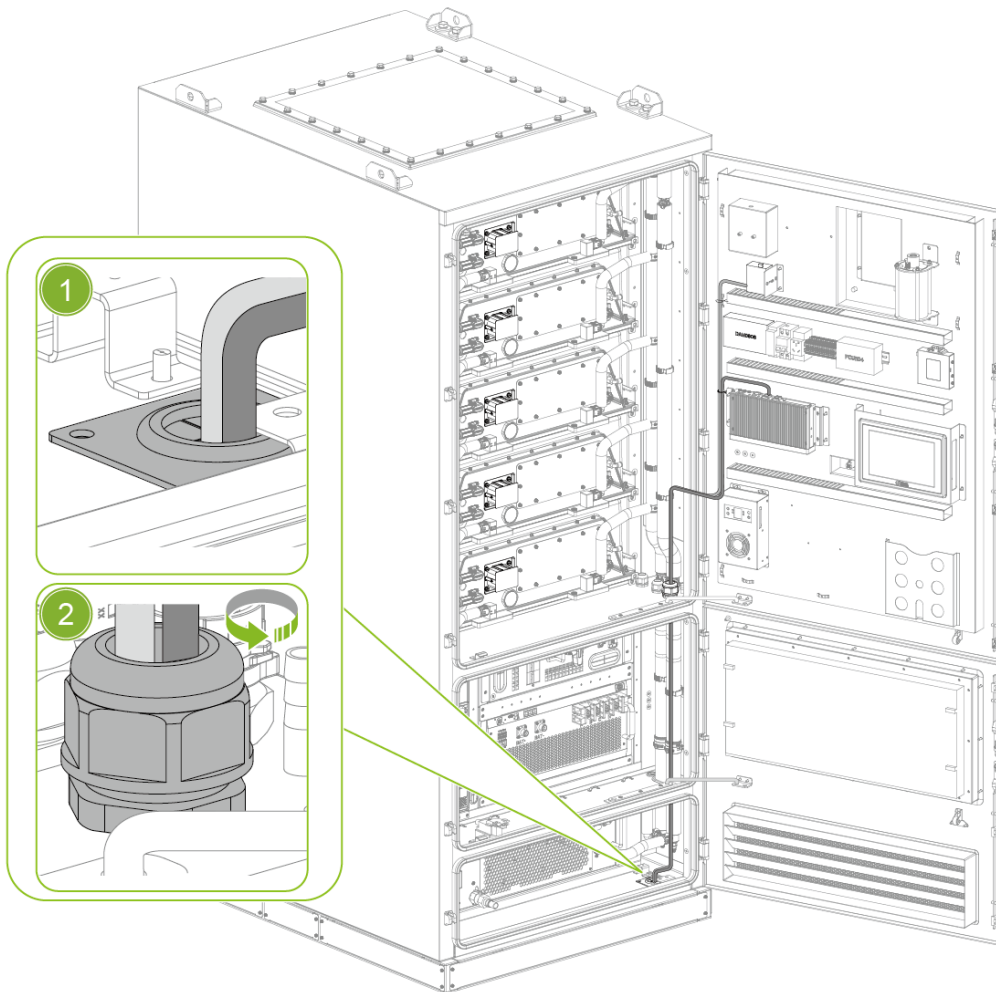

Fig. 5-12 Pass cable into the cabinet

Step 2. Connect external network cable.

1. Crimp RJ45 connector onto network cable end.
2. Connect third-party EMS to the LAN4 port of switchboard

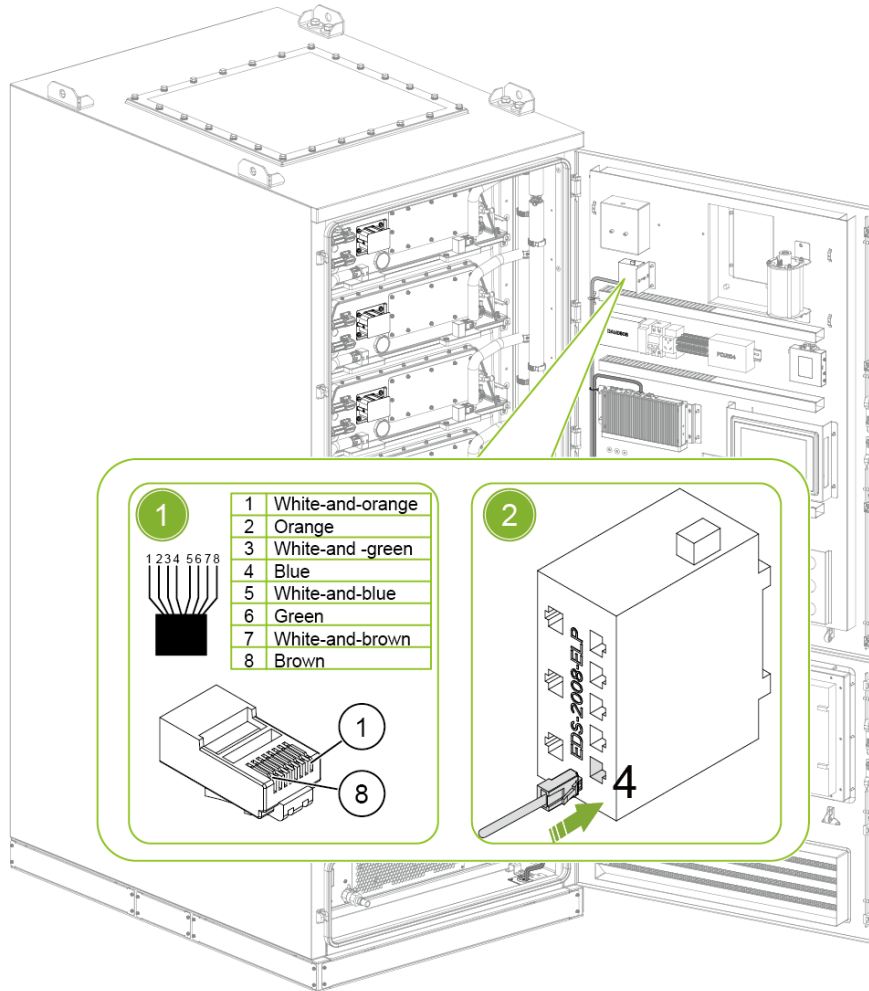

Fig. 5-13 Connect the external network cable

Step 3. Connect RS485 communication cable.

1. Strip the shielded twisted pair from external electric meter or PV devices.
2. Crimp the wires into PIN1-485A/485B of the DB9 connector.
3. Connect the DB9 connector to the COM3/4 port of EMS.

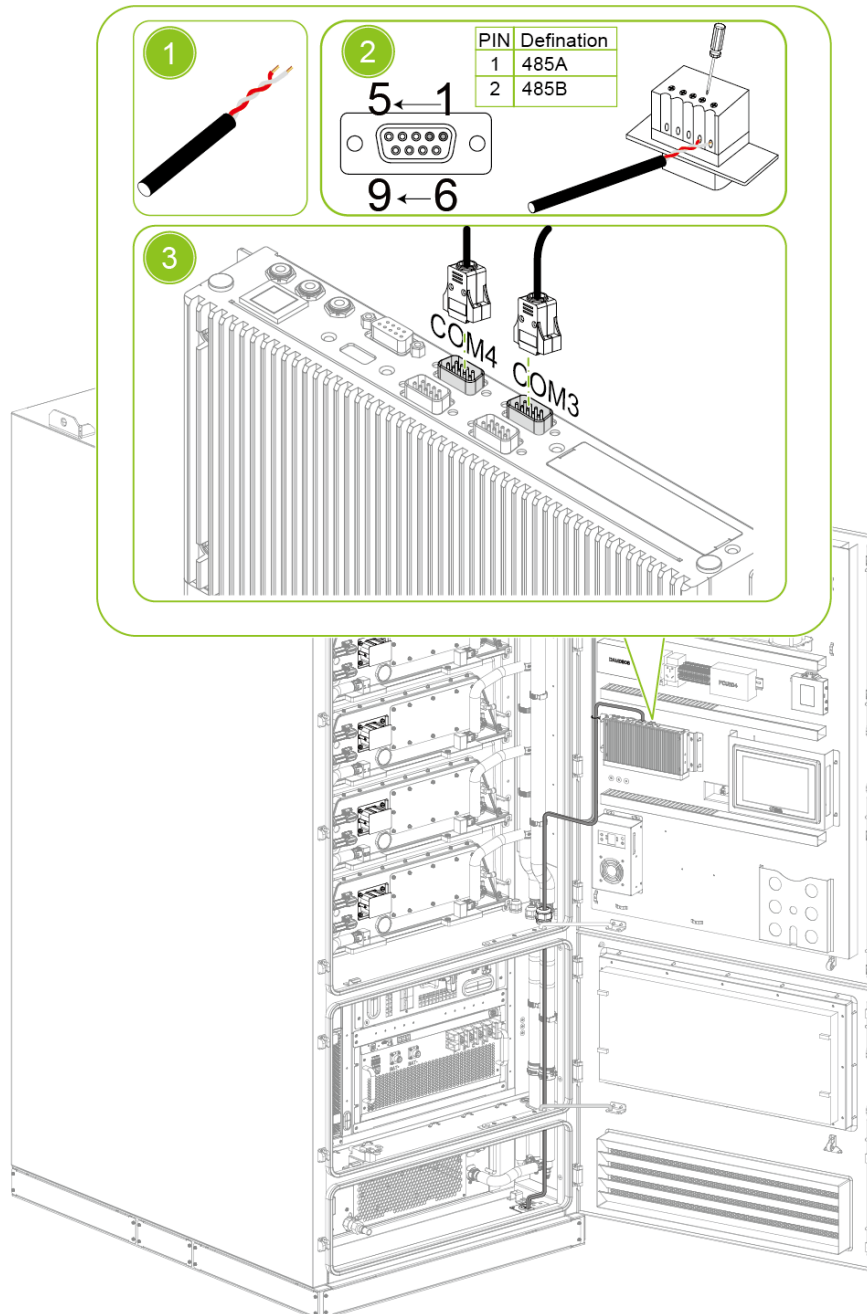

Fig. 5-14 Connect the RS485 communication cable

Step 4. Connect control cable (4).

Step 5. Adjust and bundle cables with cable ties (5).

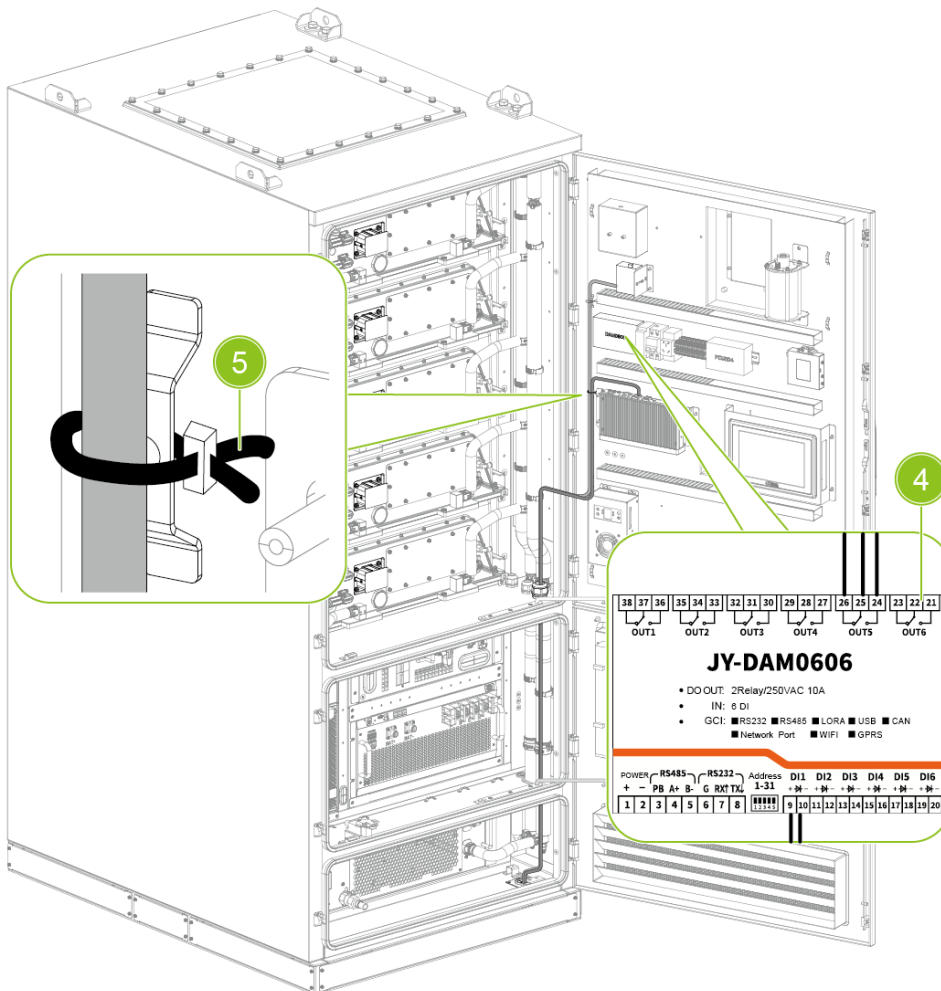

Fig. 5-15 Connect cable to controller and intall cable ties

5.5. Apply Fireproof Putty



NOTICE!

Apply fireproof putty around every bottom incoming cables to prevent watervapor ingress, air circulation and condensing inside cabinet

1. Apply fireproof putty around the AC cable.
2. Apply fireproof putty around the grounding cable and COM cables.

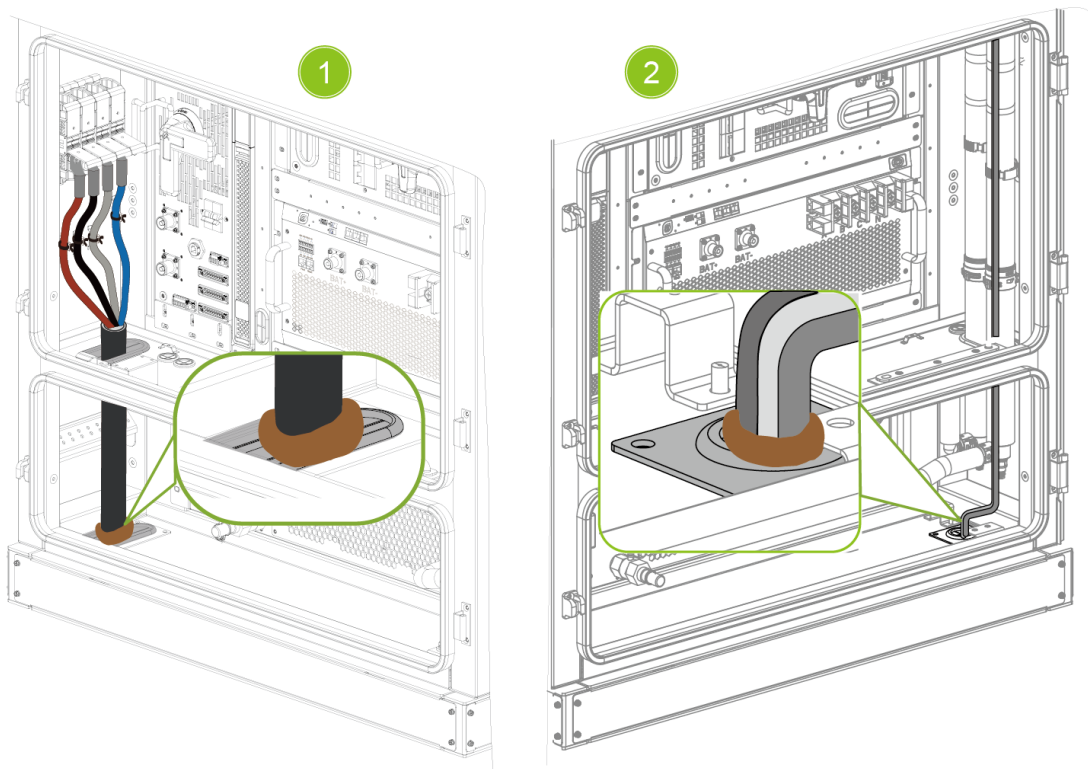

Fig. 5-16 Connect cable to controller and intall cable ties

5.6. MSD Installation

1. Remove the transparent protection cover.
2. Insert the MSD into the MSD guide slot of PACK.
3. Move handle upwards till hearing a “click” sound.
4. Push secondary lock button to lock it.

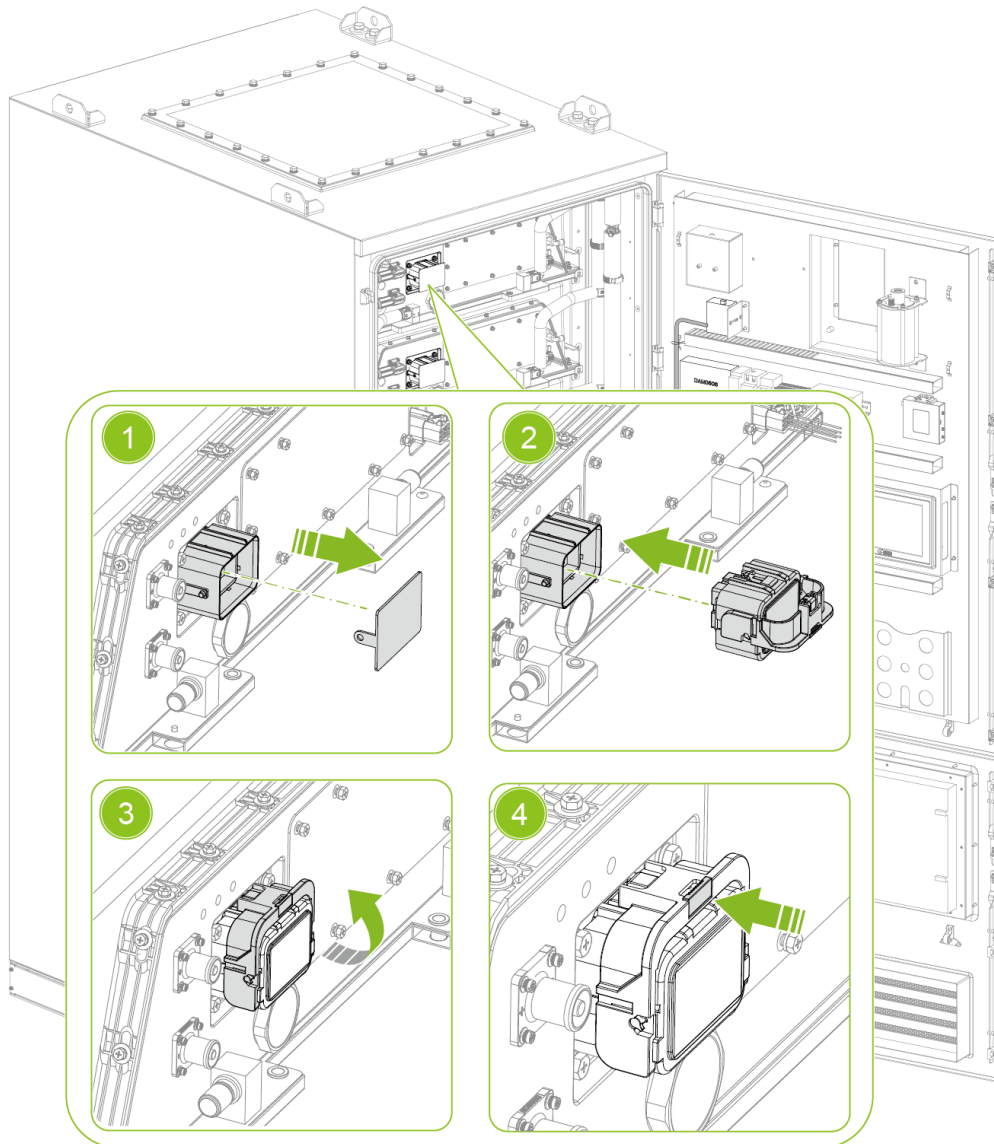

Fig. 5-17 MSD installation

6. Emergency Handling Procedure



WARNING!

To avoid death, personal injury or product damage, please follow all safety procedures stipulated in the national "Environmental Health and Safety (EHS) Guidelines".

Chint's principle is to protect everyone, including employees, customers, and contractors, from potential harm and health damage that may arise from work activities. Chint will provide and maintain a safe and healthy working environment, equipment, and work systems for all employees, and provide them with the necessary information, training, and supervision for this purpose.

Chint will attach great importance to health and safety and comply with all statutory requirements.

6.1. Emergency Stop

Scenarios of emergency stop





DANGER!

In any of the following situations, you must push the emergency stop button immediately.

- Fire and thermal runaway:
Cabinet smoking, catching fire, severe deformation and overheating of the casing, or a distinct burnt smell.
- Liquid leakage:
Electrolyte leakage, bubbling, or the cabinet being soaked in water (such as during heavy rain or pipe burst).
- Electric shock and leakage:
Personnel experiencing electric shock, or a continuous tingling sensation when touching the cabinet.
- Severe abnormal noise:
Abnormal loud noises such as cracking sounds or the opening of pressure relief valves inside the cabinet.
- Mechanical damage:
Severe deformation or tilting of the cabinet due to impact, drop, etc.
- Control system failure:
Severe fault alarms displayed on the monitor and inability to stop the machine through software, or the equipment continuing to charge and discharge out of control.

Mandatory regulations after emergency stop

	<p>IMPORTANT!</p> <p>Do not attempt to reset until the fault is resolved:</p> <ul style="list-style-type: none"> • After pressing the emergency stop button, the cause must be thoroughly investigated and the fault must be eliminated by professionals. Otherwise, it is strictly prohibited to unscrew (reset) the button and power on. • The power-on steps after resetting the emergency stop button, you can refer to Product Operating Procedures • Power on procedure in page 82.
---	---

	<p>IMPORTANT!</p> <p>It is necessary to record:</p> <ul style="list-style-type: none"> • In the equipment operation log, record the pressing time, cause, phenomenon and subsequent handling results in detail.
---	---

Important distinction

	<p>NOTICE!</p> <p>Normal Shutdown:</p> <ul style="list-style-type: none"> • During routine maintenance, routine inspections, or planned downtime, please use the normal power-on and power-off procedures (such as touch screens, monitoring systems, or normal power switches).
---	--

	<p>NOTICE!</p> <p>Prohibited Actions:</p> <ul style="list-style-type: none"> • It is strictly forbidden to use the emergency stop button as a regular switch. Frequent operations may damage the equipment or cause unexpected shutdowns.
---	---

6.2. Leakage of Electrolyte



WARNING!

Electrolyte leakage could result in serious injury.

If there is electrolyte leakage, take the following measures immediately:

- Immediately evacuate the area.
- Provide maximum ventilation, remove harmful objects or gases.
- Wipe clean with a cloth, dispose of it in a plastic bag, then place it in an iron to allow the Battery to cool and the vapor to dissipate.
- Avoid skin and eye contact or inhalation of vapor, or use absorbent to remove spilled liquid and incinerate it.

First aid measures for different parts are as follows

- Eye first aid

Rinse the eyes with plenty of water for at least 15 minutes, occasionally lifting the upper and lower eyelids, while seeking medical assistance.

- Skin first aid

Remove contaminated clothing, rinse the skin with plenty of water or shower for 15 minutes, while seeking medical assistance.

- First Aid for Accidental Inhalation

Immediately move from the leak area to a place with fresh air, and use oxygen if available.

- First Aid for Accidental Ingestion

Immediately drink milk or water, induce vomiting, and seek medical attention immediately if the patient loses consciousness.

6.3. Fire

6.3.1. Classification of Fire Hazards

Table 6-1 Classification of fire hazards

No.	Fire risk	Detailed description	Corresponding measures
1	Internal short circuit	Dangers of low battery voltage, overheating, and battery swelling	The system is certified by UL 9540, and the rack is certified by IEC 62619, UL 1973, and EMC safety tests.
2	External fire source	If the temperature exceeds 130°C, there is a risk of battery failure and fire	The equipment body has a fireproof insulation layer, as long as the equipment is kept away from fire and heat sources.
3	External heat source		
4	External short circuit	During the installation process, or if the fuse is not installed properly, there may be risks of external short circuits, arc flashes, and fires.	Install the screws according to the manual and conduct a comprehensive inspection to ensure each one is tightened.
5	Loose screws	Causes excessive contact resistance, heating at the connection points and cables	
6	Overcharging	This situation only occurs when the system does not detect BMS faults, protections, parameter errors, or communication failures	The system complies with the UL1973 standard, has a dual protection system of software and hardware, and has low risk
7	Over-discharge		

6.3.2. Fire Risk Deduction

Consider from five aspects: component safety, battery cell safety, electrical safety (BMS), mechanical safety, and environmental safety.

Component safety

Table 6-2 Components comply with IEC standards

No.	Component name	Compliance standard number
1	Plastic Components	IEC 60707
2	Fuse	IEC 60269
3	Relay	IEC 60947
4	BMS	IEC 60950
5	Anti-corrosion	IEC 60068

Battery cell safety

Battery design complies with standards such as UL1642, IEC62133, UN38.3, etc.

Electrical Safety

Table 6-3 Protection threshold (reference)

BMS function	Detailed description	Parameter
Single Cell Overcharge	Overcharge Voltage Protection Threshold	3.65 V
	Overcharge Protection Delay Time	3 s
Single cell over-discharge	Over-discharge voltage protection threshold	2.50 V
	Over-discharge protection delay time	3 s
	Discharge recovery voltage threshold	3.0 V
Battery PACK overcharge	Overcharge Voltage Protection Threshold	189.8 V
	Overcharge Protection Delay Time	3 s
	Overcharge recovery voltage threshold	182 V
Battery PACK over-discharge	Over-discharge voltage protection threshold	130 V
	Over-discharge protection delay time	3 s
	Discharge recovery voltage threshold	156 V
Overcurrent protection	Discharge overcurrent protection delay time 1	5 s
	Discharge overcurrent protection threshold	Refer to the alarm threshold table
	Discharge overcurrent protection delay time 2	500 ± 50 ms
	Charge overcurrent protection	Refer to the alarm threshold table
Short circuit	Short circuit protection	/

	Protection conditions	Load short circuit
	Recovery conditions	Load disconnection
Over-temperature protection	Charging high temperature protection	55 °C
	Charging temperature recovery	45 °C
	Discharge high temperature protection	55 °C
	Discharge temperature recovery	45 °C
	Charging low temperature protection	0 °C
	Charging temperature recovery	5 °C
	Discharging low temperature protection	-20 °C
	Discharge temperature recovery	0 °C

Dual protection mechanism (see the figure below)

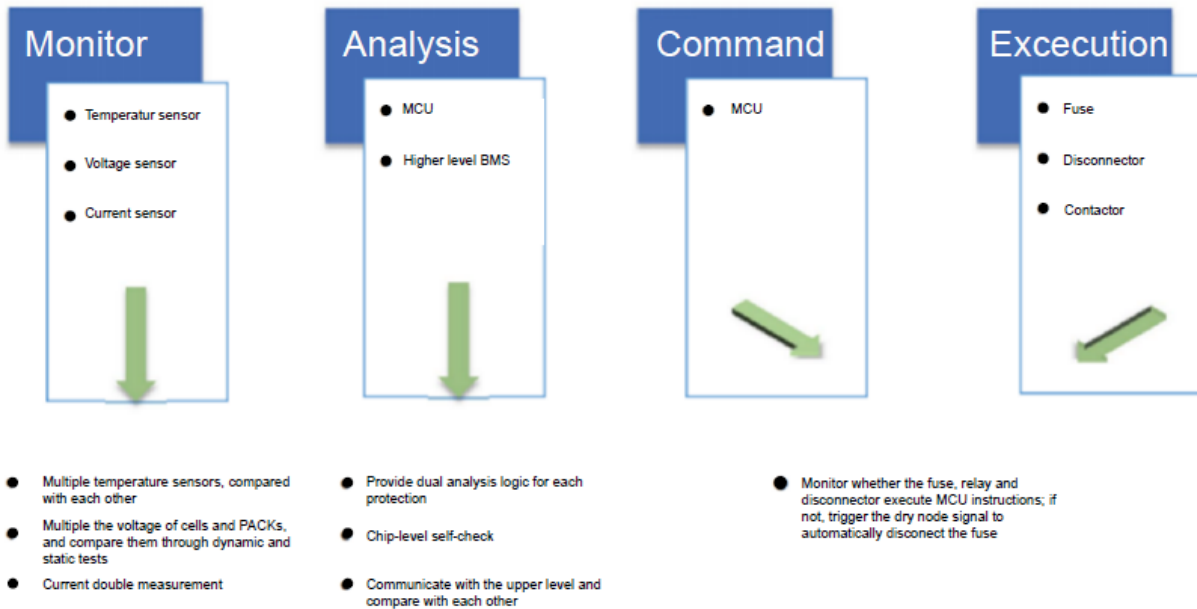

Mechanical Safety

Complies with UN38.3 standard, passing tests such as static pressure, impact, drop, installation, etc.

Environmental safety

Preventive measures: temperature monitoring, UL94-V0 material, metal casing, safety valve design, BMS high-temperature protection, etc.

6.3.3. Identify Fire Hazards**Ignition source**

There are no obvious ignition sources in the entire equipment system environment, and smoking is prohibited near the equipment.

Combustion fuel

No fuel, no large amount of paper; only some maintenance record paper.

Work process

No process will cause serious fire hazard.

6.3.4. Measures When There is Fire**Actions to take after hearing the alarm**

- Do not approach, do not open the door, and leave immediately.
- Only when your own safety is ensured can you remotely cut off the power supply.
- Immediately notify the relevant person in charge to investigate the cause of the alarm.

Actions to be taken after discovering a fire

- Use the nearest fire alarm call point to raise the alarm
- Report to the safe assembly point
- Call the fire brigade using a mobile phone (after leaving the equipment)
- Contact them after the fire brigade arrives
- Even if you are confident, do not attempt to handle small fires
- Do not put yourself in danger of fire

6.4. Flood and Water Disaster

- Under the premise of ensuring personal safety, power off the system; for the system power-off operation procedure, please refer to Section 6 System Power On/Off Operation Procedures.
- If any part of the battery is submerged in water, do not touch the battery to avoid electric shock.
- Do not use batteries that have been flooded; contact a battery recycling company for disposal.

7. Operation Procedure

7.1. Power-on Procedure

7.1.1. Pre-power-on Inspection



CAUTION!

Before power on procedure, make sure the AC voltage of the mains input terminals (MAINS) is within the normal range by using a multimeter.

No.	Inspection item	Inspection content
1	Symbol inspection	<ul style="list-style-type: none"> The nameplate, company logo and warning signs are correct, complete and clear, and comply with product standards. The grounding symbol is clear, the contact surface of the grounding device should be free of paint and rust.
2	Door inspection	<ul style="list-style-type: none"> The opening and closing of the cabinet door should be smooth and flexible, the opening angle $\geq 90^\circ$. During the opening and closing process of the cabinet door, the coating layer should not be damaged and ensure sealing. The protective strips around the door should be flat, without delamination or curling. After opening and closing for 5 times, the door should be securely locked, and its movement should not exceed 2 mm. The verticality of the door should meet the design requirements. After closing, the areas around the door and the ventilation window should be tightly fitted, with no light penetrating through.
3	Appearance inspection	<ul style="list-style-type: none"> The inner and outer surfaces of the cabinet are uniformly coated without any pinholes, bubbles, run-offs, or bottom leakage. When viewed from 1 m away, no scratches, stains, or repair marks can be seen. The interior of the cabinet is clean and there should be no wire ends, cable ties, iron or copper scraps, or other debris.

No.	Inspection item	Inspection content
		<ul style="list-style-type: none"> The internal surfaces of the cabinet and the copper strips and components are uniformly smooth and shiny, with good adhesion and no rusting.
4	Key component inspection	<ul style="list-style-type: none"> The copper strips and component coatings are uniformly smooth and clean, with good adhesion and no rusting phenomenon.
5	Dust filter inspection	<ul style="list-style-type: none"> The dust filter screen should be installed flatly without any looseness. The filter insertion and removal should be smooth without any obstruction (pay attention to the position of the air intake surface of the dust filter screen).
6	Key electrical contacts firmness inspection	<ul style="list-style-type: none"> The system equipment is installed with bolts tightened. The torque of each nut should comply with the standards, and it should be marked. Random tests should be conducted on the torque of the nuts at key parts. The connection cables and grounding wires should be installed correctly and firmly.
7	Connection between battery PACK (No MSD)	<ul style="list-style-type: none"> The interface between the observation module and the module connector should be pressed tightly, and the snap should fully return to its original position. Additionally, check that the polarity of the module's connection wiring is correct.
8	Connection between high voltage box and battery PACK (No MSD)	<ul style="list-style-type: none"> The connection between the high-voltage box and the battery module is via connectors. It should be pressed tightly, with the snap fasteners fully retracted, and ensure that the polarity markings of the high-voltage box and the battery module are consistent.
9	Control circuit between cabinets	<ul style="list-style-type: none"> Check whether the cables between each cabinet are laid correctly according to the "cable layout diagram", and the wiring on the terminals should be consistent with the drawings. Pay special attention to the correct phase color of the alternating current. The wire colors are L1 (brown), L2 (black), L3 (grey), N (blue), and PE (yellow-green). If the cable (wire) color does not meet the requirements, corresponding colored heat shrink tubing must be sleeved at both ends of the cable to

No.	Inspection item	Inspection content
		<p>mark the color. Communication cables must use cables with a shielding layer.</p>
10	Auxiliary circuit power supply test	<ul style="list-style-type: none"> • Measure the line voltage at the input end of QF1 to be AC 220V. After confirming it is correct, close QF1. Confirm that the line voltage at the output end of QF1 is also AC 220V. The liquid cooling machine and dehumidifier should be powered on and running. • Measure the line voltage at the input end of QF2 to be AC 220V. After confirming it is correct, close QF2. Confirm that the line voltage at the output end of QF2 is also AC 220V. At this point, the 24V DC power supply, 12V DC power supply, BMS, EMS, and fire protection system should be powered on and started. • Disconnect QF1 and QF2. After confirming it is correct, close QF3. At this point, the 24V DC power supply, 12V DC power supply, BMS, EMS, and fire protection system should be powered on and started.
11	Power supply test for the drive circuit	<ul style="list-style-type: none"> • The line voltage at the input end of QF was measured to be AC 400V. After confirming, close QF. Then, the line voltage at the output end of QF was confirmed to be AC 400V. At this point, the PCS should be in an energized state and the power indicator light should be on.
12	Communication check and inspection of all protection parameters	<ul style="list-style-type: none"> • The EMS (enter the IP address of the EMS webpage and log in to facilitate information comparison) reads the data between the modules and checks the voltage, current, power, battery status, energy storage converter status, thermal management system status, fire protection system status, ventilation device status, cabin temperature and humidity, etc.
13	Charge and discharge test	<ul style="list-style-type: none"> • Connect the system to the power source or the grid, connect the auxiliary power supply, activate the battery management system, the thermal management system and the fire protection system, close switch QF, start PCS, close the high-voltage box, close the door for testing to prevent condensation. • Send the system startup command through the PCS upper computer, record the equipment operation status.

No.	Inspection item	Inspection content
		<ul style="list-style-type: none"> Set the power to charge or discharge at 10%Pn, record the running power value for 5 minutes. During the test, the water-cooling machine should automatically cool or heat. After continuous operation for 5 minutes, press the emergency stop button, the system stops charging and discharging, the PCS reports an emergency stop fault, the door panel indicator light turns red, release the emergency stop button, the PCS emergency stop fault is reset, and the door panel indicator light turns green. Under the 10%Pn condition, there are no alarms or protections during operation, and full-power charging and discharging can be performed.

7.1.2. Power-on Operation Procedures

1. Close the circuit breakers QF1(1), QF2 (2), QF3 (3), QF4 (4) in sequence.

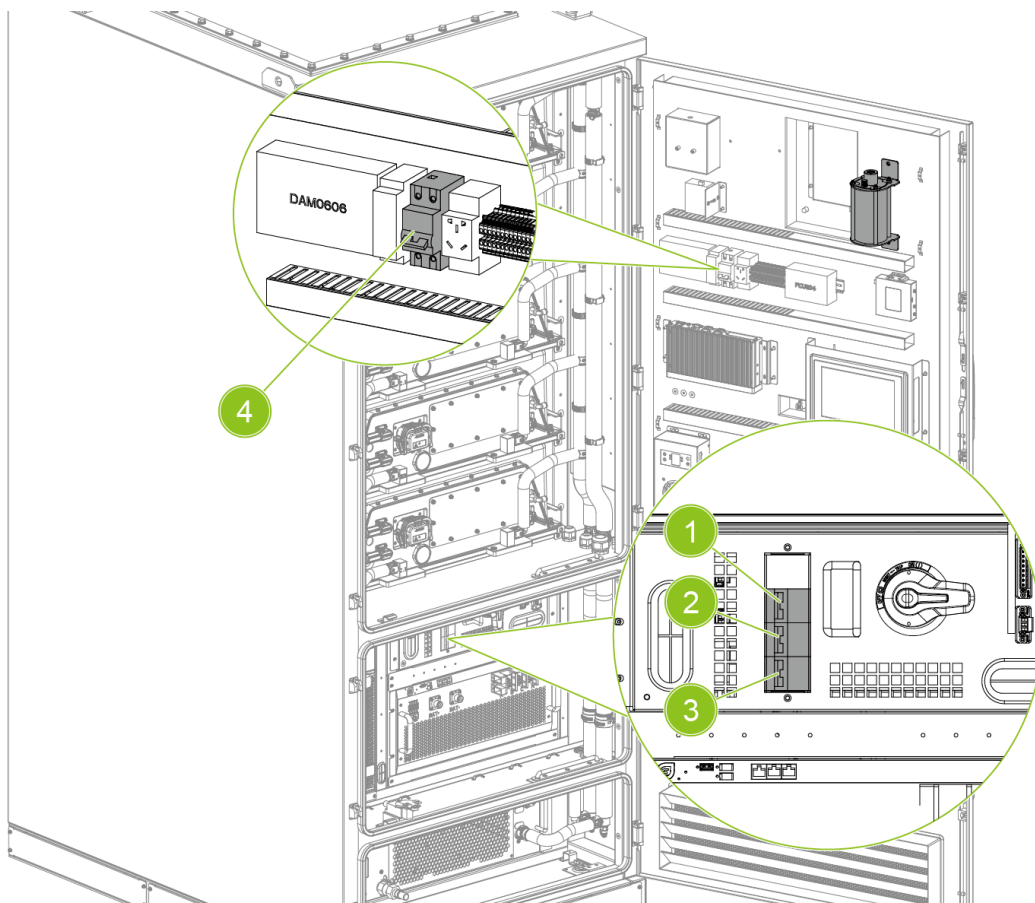

Fig. 7-1 Power-on step 1

2. Press and hold the UPS power button (5) for 3 seconds to power on the UPS, and check the output voltage AC220V on the UPS panel.
3. Close the disconnecter QS (6) and the miniature circuit breaker QF (7) on the high voltage box, as shown in Figure 3-13.
4. Close molded case circuit breaker QF (8) on the distribution box.

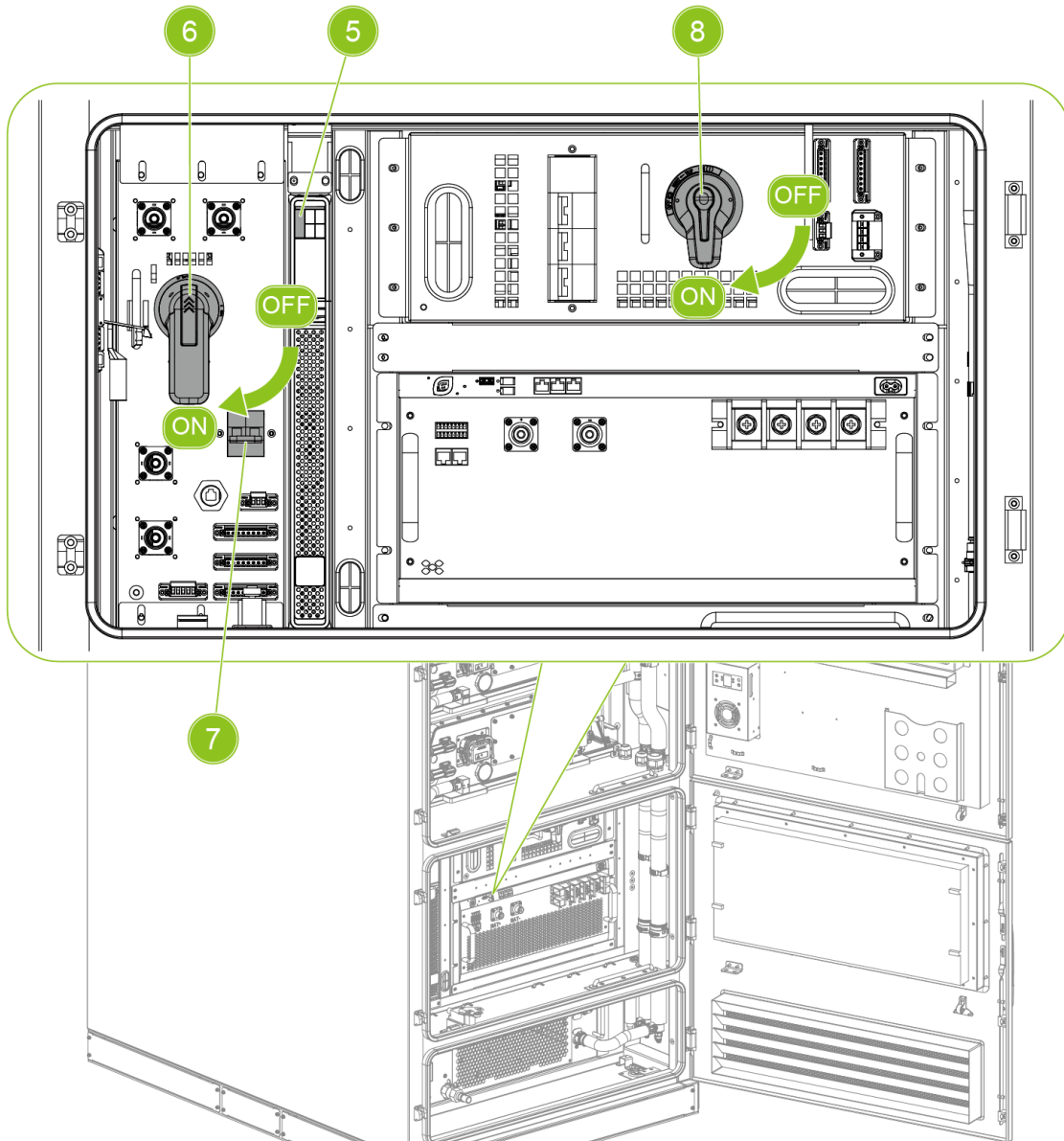

Fig. 7-2 Power-on step 2-4

7.1.3. Inspection after Power-on

1. Check whether the BMS display screen is functioning properly, and verify whether the total voltage of each battery cluster and the voltage of each battery cell are normal. Ensure that the BMS connection is normal.
2. Check whether each device in the battery system is operating normally, and verify whether the power lines and communication lines of each sub-unit of the BMS are correctly connected.

3. Check if the high-voltage box has any faults and if it is in a normal state.
4. Check if the liquid cooling machine is working properly. If there is a fault, refer to the troubleshooting section.
5. Check if the fire controller is working properly. If there is a fault, refer to the fire protection product manual.
6. After the equipment is finally installed at the project site, the system should undergo another safety review before it starts operating.

**IMPORTANT!**

To ensure the continuous and safe operation of the system throughout its entire life cycle, we need to conduct daily inspection and record-keeping.

7.2. BMS System Operation Procedures

BMS System Architecture

Chint strongly recommends that the BMS be configured and commissioned by authorized factory representatives, otherwise it will not be covered by the warranty.

ESMU can communicate with LEMS via ModbusTCP. ESMUs do not communicate with each other and should be treated as an independent subsystem. LEMS identifies different ESMUs by IP address. An example architecture is shown below:

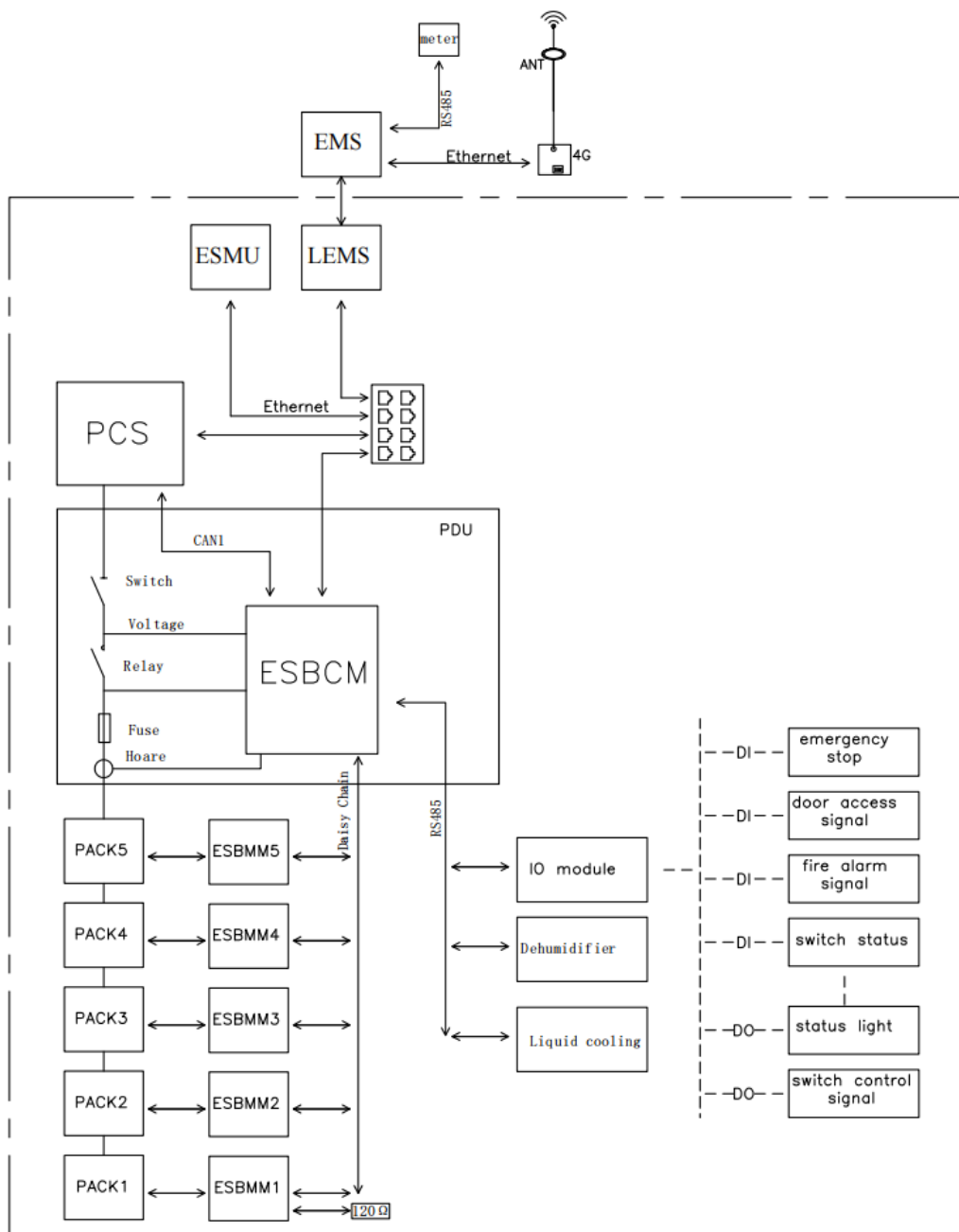

Fig. 7-3 BMS system architecture diagram

System Configuration Preparation

Before system configuration, the following materials need to be prepared:

- Communication cable: for CAN / RS485 connection
- Adapter: matching high voltage box debugging port connector
- CAN box: USB to CAN tool for PC
- RS485 tool: USB to RS485 tool for PC
- Software: BMS host computer, CAN Test, serial port tools, etc.
- Standard network cable: Connect to ESMU to communicate with PC
- Laptop: Pre-installed with Windows 7 SP1 or a higher version of the operating system

BMS system configuration



WARNING!

- In the battery cluster, the ESBMM address will be automatically assigned without the need for separate configuration.
- When replacing the ESBMM, disconnect the AC power supply and circuit breaker of the high voltage box.
- After replacing the ESBMM, restore according to the normal power-on process.

1. ID information of ESBMM

After the system is installed or the ESBMM is replaced, since the battery cluster adopts a daisy-chain communication method, there is no need to actively assign the address of the ESBMM.

2. CAN data upload

As shown in the figure below, all ESBMMs communicate with ESBCM through a daisy-chain method. Each ESBMM has a unique ID on the battery cluster and has the function of address allocation.

ESBCM can collect data from all ESBMMs, and ESBMMs can also update data and send warnings to ESBCM via the daisy-chain.

ESBCM communicates with the master ESMU through LAN data.

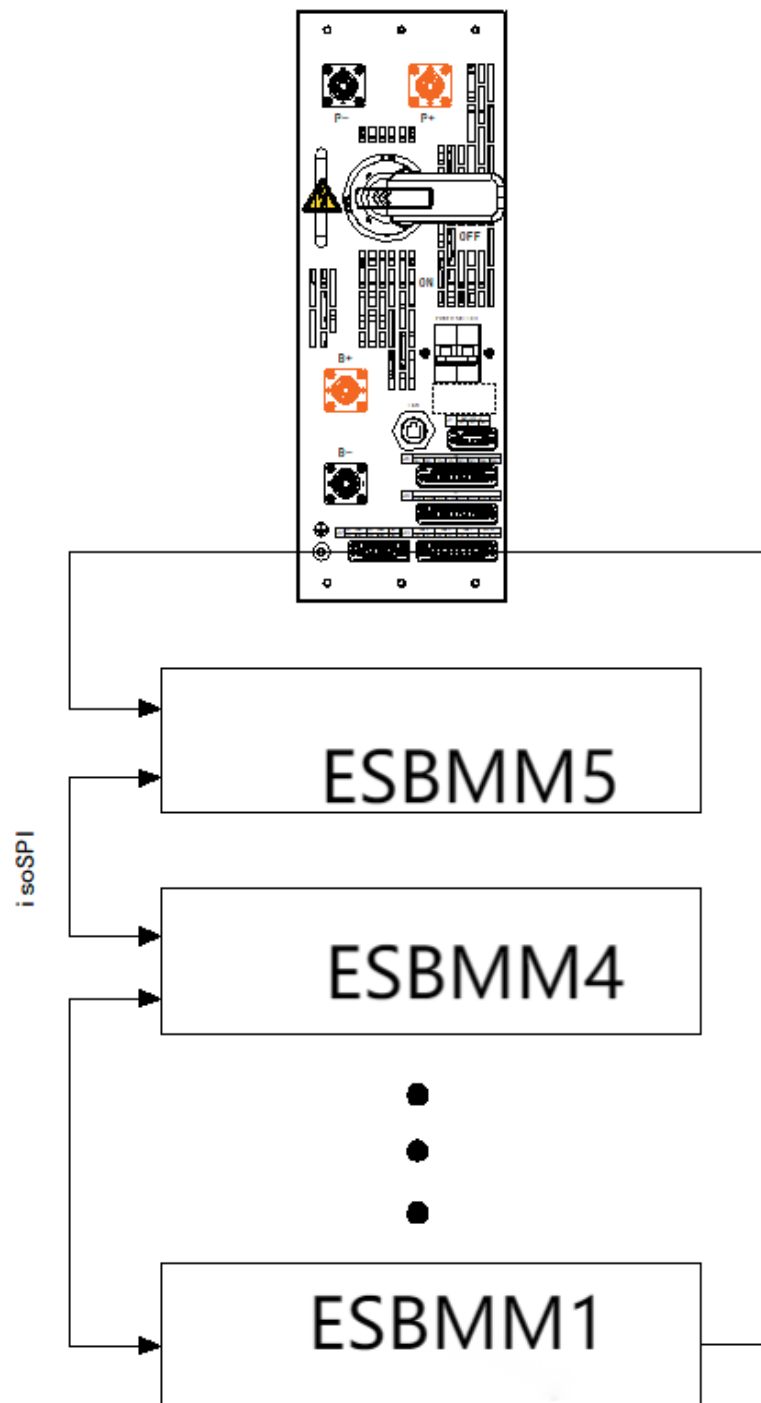

Fig. 6-1 Communication architecture between ESBMM and ESBCM

3. Software online upgrade

The internal software logic of ESBMM is implemented by ESBCM, and no software upgrade is required. For updates that may involve BMS, BMS can upgrade all ESBCM software through CAN communication. The software upgrade can be easily completed by importing the latest program through ESMU.

ESMU Configuration

- The system automatically enters the main interface upon startup, which displays information such as the total voltage and total current of the battery system (1), as well as the voltage value, current value, SOC value, and working status of the battery cluster.

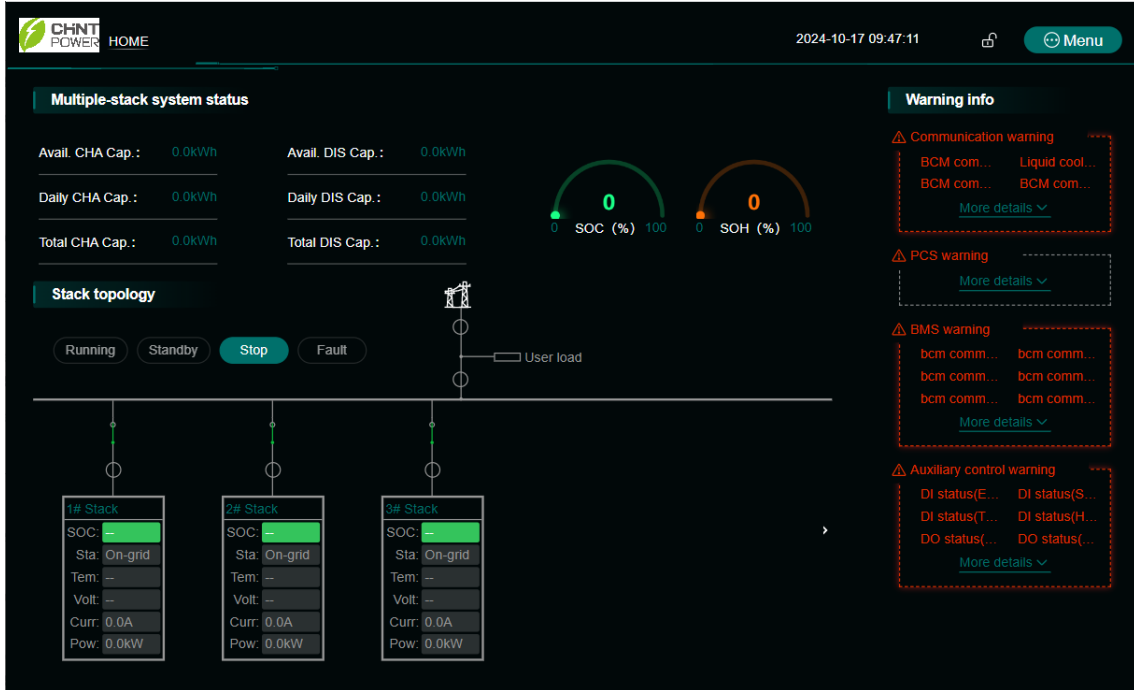

Fig. 7-4 Main interface

- Click the icon of the battery cluster in the main interface to display detailed information of the battery cluster, including voltage, current, SOC, SOH, charge/discharge capacity, maximum and minimum voltage and temperature of the fault battery cells, and other key information.

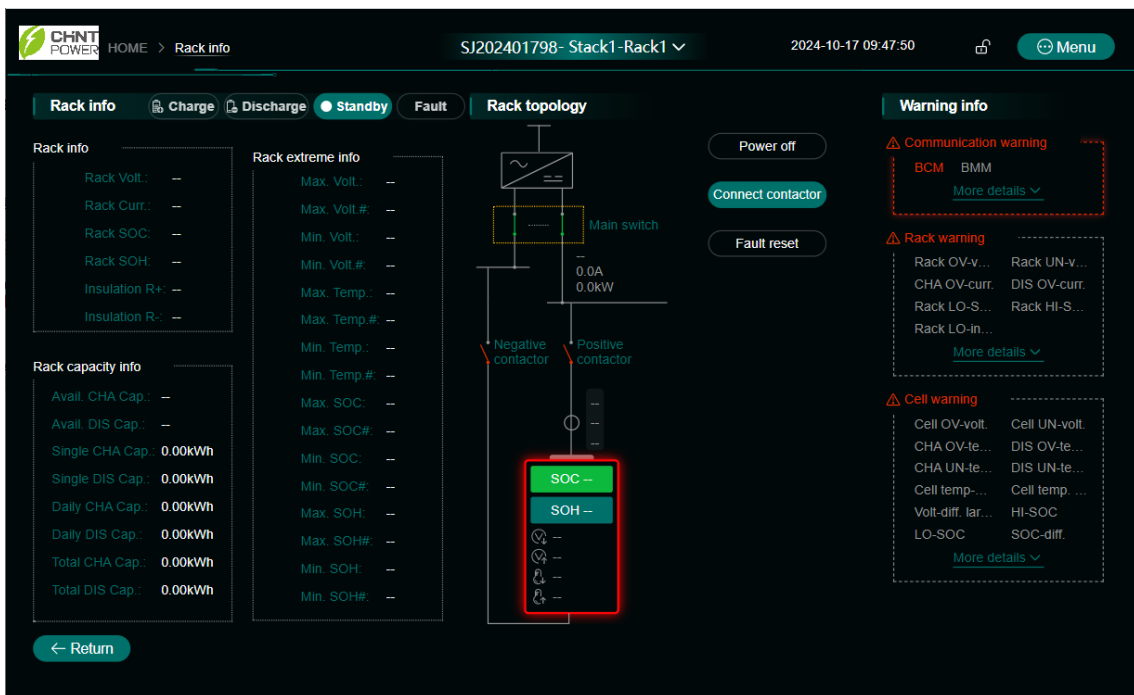

Fig. 7-5 Battery cluster parameters (reference)

- Click the icon of the battery PACK in the above figure to display the voltage of each battery PACK, the temperature at each position, warning/fault information, etc.

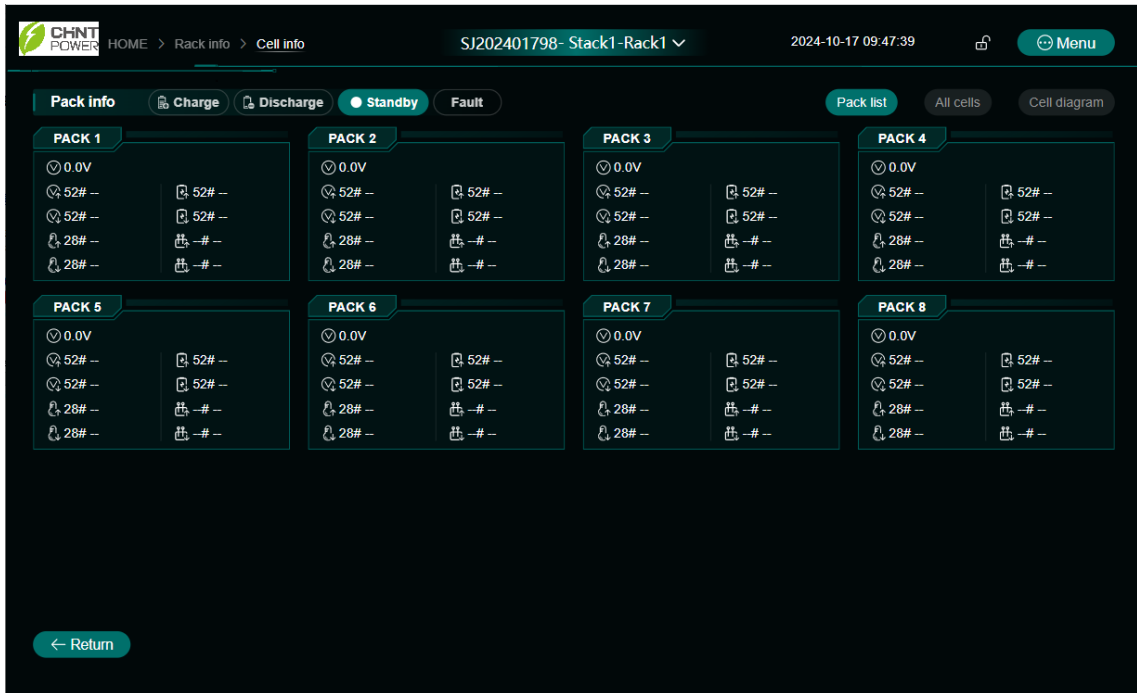

Fig. 7-6 Battery PACK parameters (reference)

Network port configuration

After installation, wiring, and configuration, connect the Ethernet cable to the ESMU, communicate via MODBUS, and check if the system BMS provides correct data.

The default IP addresses are: LAN0: 10.122.1.88, LAN2: 195.16.19.88.

Port Number: 502

Typical protection strategy

The basic protection strategy is outlined as follows (may vary according to the specific requirements of the application):

- Source of protection signals
 - Module/unit information based on BMS analysis and alarm triggering
 - BMS hardware failure
 - Communication issues within the BMS or with the LEMS/PCS
 - The BMS sends signals to the PCS/LEMS via Modbus
- The LEMS/PCS shuts down the inverter
- If the inverter does not shut down within 3-5 seconds, the BMS activates a hardwired signal to shut down the inverter

7.3. PCS Operation Procedures



For more information, please contact customer support.

7.4. LEMS Operation Procedures



For more information, please contact customer support.

7.5. Parameter Setting

7.5.1. BMS Parameter Settings

1. Confirm the ESBCM (main control) version and ESMU (display control) version information.
ESBCM Version: SV_CF133_b3_5.0.1_GB1.118_20241797_01.33
2. ESMU version: AARCH64-ESMU-G01-ZT-V11-R20250514150113-SJ202401797-20
The IP address of ESBCM (main control) is 195.16.19.201
ESMU (display control) IP address: LAN0: 10.122.1.88, LAN2: 195.16.19.88.
3. Confirm the protection parameter threshold through ESMU.

Table 7-1 Protection parameter threshold

No.	Project	Alarm level	Alarm trigger threshold	Hysteresis value
1	Single cell voltage too high (V)	Minor	3.5	0.1
		Moderate	3.6	
		Serious	3.65	
2	Single cell voltage too low (V)	Minor	3.0	0.1
		Moderate	2.8	
		Serious	2.5	
3	Single cell voltage difference (mV)	Minor	350	100
		Moderate	400	
		Serious	600	

No.	Project	Alarm level	Alarm trigger threshold	Hysteresis value
4	Battery charging cell temperature high (°C)	Minor	45	5
		Moderate	50	
		Serious	55	
5	Battery charging cell temperature low (°C)	Minor	5	5
		Moderate	0	
		Serious	-20	
6	Battery discharging cell temperature high (°C)	Minor	45	5
		Moderate	50	
		Serious	55	
7	Battery discharging cell temperature low (°C)	Minor	0	5
		Moderate	-10	
		Serious	-20	
8	Large temperature difference between cells in the cluster (°C)	Minor	10	5
		Moderate	15	
		Serious	20	
9	SOC low (1%)	Minor	10	5
		Moderate	0	
		Serious	0	
10	SOC high (1%)	Minor	95	5
		Moderate	100	
		Serious	100	
11	Total voltage too high (V)	Minor	3.5	22.5

No.	Project	Alarm level	Alarm trigger threshold	Hysteresis value
	(*260)	Moderate	3.6	
		Serious	3.65	
12	Total voltage too low (V) (*260)	Minor	3.0	22.5
		Moderate	2.8	
		Serious	2.5	
13	Power connector over-temperature alarm (°C)	Minor	65	5
		Moderate	70	
		Serious	80	
14	Charging overcurrent (A)	Minor	180	10
		Moderate	200	
		Serious	220	
15	Discharging overcurrent (A)	Minor	180	10
		Moderate	200	
		Serious	220	
16	Low insulation (KΩ)	Minor	1000	10
		Moderate	500	
		Serious	200	
17	Battery PACK voltage too high (V) (*52)	Minor	3.5	5
		Moderate	3.6	
		Serious	3.65	
18	Battery PACK voltage too low (V) (*52)	Minor	3.0	5
		Moderate	2.8	
		Serious	2.5	
19	Display control and ESBCM communication failure	Moderate	/	/

No.	Project	Alarm level	Alarm trigger threshold	Hysteresis value
20	ESBCM and ESBMM communication failure	Serious	/	/
21	Display control detects external signals: fire alarm/emergency stop signal/electric operation	Serious	/	/
22	Single cell voltage acquisition failure	Serious	/	/
24	Single cell temperature acquisition failure	Serious	The number of invalid temperatures ≥ 2 or the number of slave controls with invalid temperatures ≥ 2	/
25	Temperature rise alarm	Moderate	The temperature rise rate of a single battery is greater than $>10^{\circ}\text{C}/\text{min}$	/
26	Main control: circuit breaker fault/contactors fault	Serious	/	/

7.5.2. PCS Parameter Settings

1. The default IP address of PCS is 10.122.1.221.
2. PCS version confirmation: Connect to the switch, use the host computer to read PCS version information, main DSP: 0.1.0.7.6.16 FPGA: 0.0.0.1.4.0 secondary DSP: 2025.2.24.
3. Set the corresponding parameters in the PCS host computer software according to the table below:

Table 7-2 Protectio Software parameter settings

Name	Parameter bit	Definition	Parameter code
23: Fault word	G23.00	Hardware fault word 1	0B,0000,0000,0000,0000
	G23.01	Hardware fault word 2	0B,0000,0000,0000,0000
	G23.02	Grid fault word	0B,0000,0000,0000,0000
	G23.03	Busbar fault word	0B,0000,0000,0000,0000
	G23.04	AC capacitor fault word	0B,0000,0000,0000,0000
	G23.05	System fault word	0B,0000,0000,0000,0000

Name	Parameter bit	Definition	Parameter code
	G23.06	Switch fault word	0B,0000,0000,0000,0000
	G23.07	Other fault word	0B,0000,0000,0000,0000
	G23.16	Hardware fault 1 mask word	0B,0000,0000,0000,0000
	G.23.21	System fault word mask word	0B,1100,0010,0101,1000
80.System configuration parameters	G.80.142	PCS heartbeat register 1-255	Check observation
	G.80.143	PCS communication heartbeat fault enable	Set parameter value to 1
20. Debug Control Quantity	G.20.05	Hardware Debug Command	0B,0000,0000,0000,0000
22. Save Register	G.22.51	Battery Overvoltage Point	960
	G.22.17	Bus Overvoltage Point	960

7.5.3. LEMS Parameter Settings

1. LEMS uses the LAN2 port, the LAN1 address is 192.168.1.100, and the LAN2 address is 10.122.1.100.
2. LEMS confirms the liquid cooling unit setting parameters:

Table 7-3 LEMS liquid cooling unit parameter settings

Parameter name	Value	Unit
Cooling Setpoint	28	°C
Heating Setpoint	10	°C
Cooling sensitivity	2	°C
Heating sensitivity	4	°C

3. Other protection parameters and strategy parameter settings are modified according to project requirements.

7.5.4. Liquid Cooling Unit Parameter Settings

1. To confirm the parameters of the liquid cooling unit, you need to connect the handheld screen to the debugging port.
2. Confirm the cooling sensitivity is 2°C and the heating sensitivity is 2°C.
3. Confirm that the Modbus-RTU communication address of the liquid cooling unit is 3.

7.5.5. Dehumidification Parameter Settings

1. The parameters of the dehumidifier need to be set during the self-check state of the dehumidifier, which occurs during the startup phase of the dehumidifier.
2. The dehumidification start value is 50%, and the dehumidification stop value is 40%.
3. Confirm that the Modbus-RTU communication address of the dehumidifier is 1.

7.5.6. Auxiliary Meter Parameter Settings

Refer to the following table for the parameters of Main Circuit Meter (kWh1).

Table 7-4 Main circuit meter (kWh1)

Parameter name	Value
Communication protocol	Modbus-RTU
Address	1
Baud rate	9600
Check bit	8
Stop bit	1
Check method	None
Voltage ratio	1
Current ratio	1

7.5.7. I/O module Parameter Settings

1. The communication method between the I/O module (2n) and ESBCM is serial communication, and the dial code needs to be moved to position 2.
2. The communication method between the I/O module (6n) and ESBCM is serial communication, and the dial code needs to be moved to position 2.

7.6. Power-off Procedure

1. Operate the LEMS system to issue a PCS shutdown command.
2. Observe the PCS indicator light (1): if it flashes slowly (flash for 1 second), the PCS is shut down.

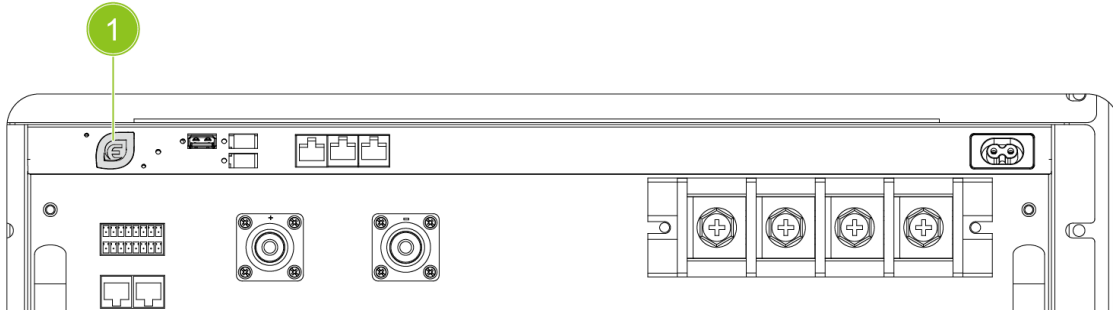

Fig. 7-7 PCS panel diagram

3. Open the molded case circuit breaker QF (2) on the distribution box.
4. Open the disconnecter QS (3) and the miniature circuit breaker QF (4) on the high voltage box.
5. Press and hold the UPS power button (5) for 3 seconds to power off on the UPS.

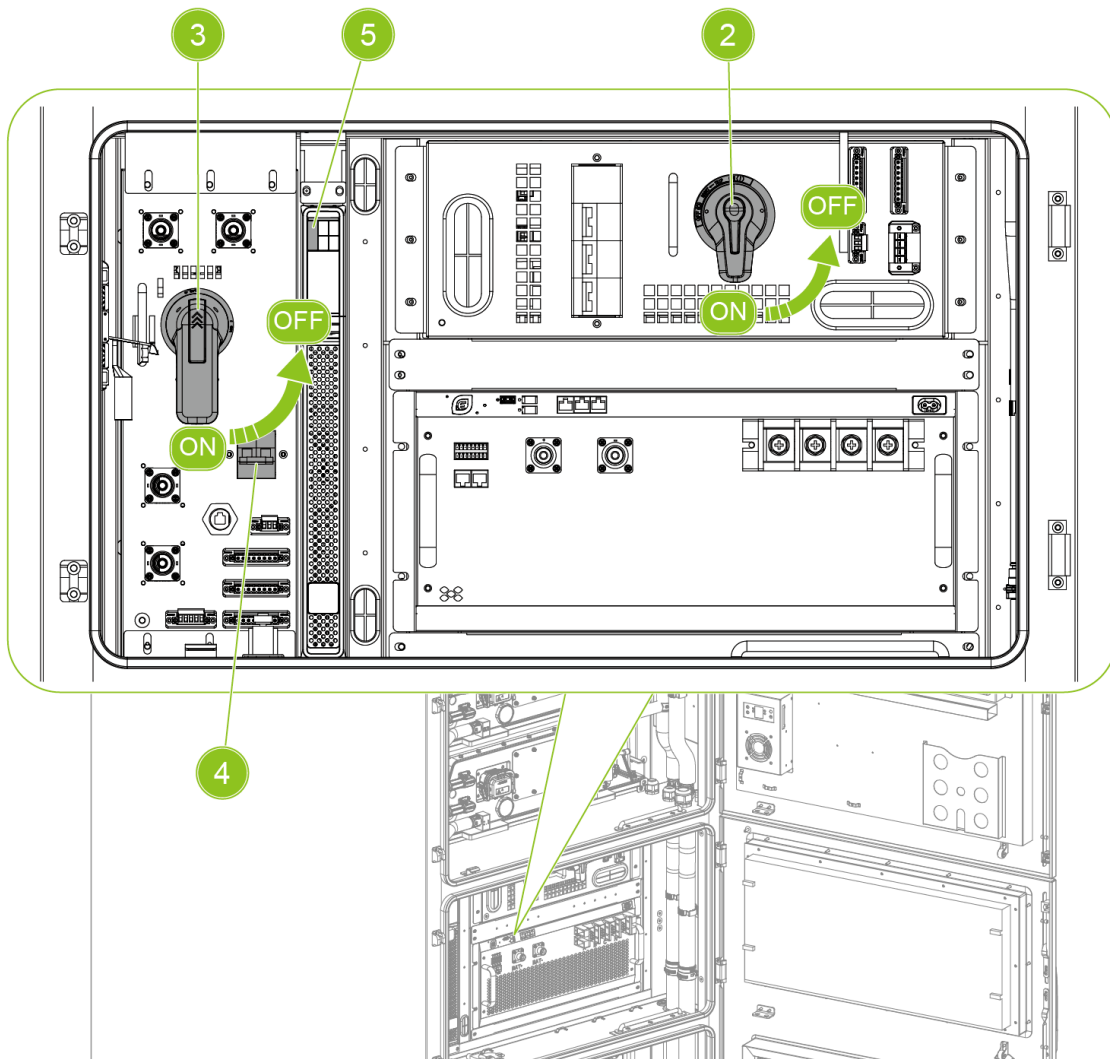

Fig. 7-8 Power off procedure

6. Open the circuit breaker QF4 (5), QF3 (6), QF2 (7), QF1 (8) in sequence.

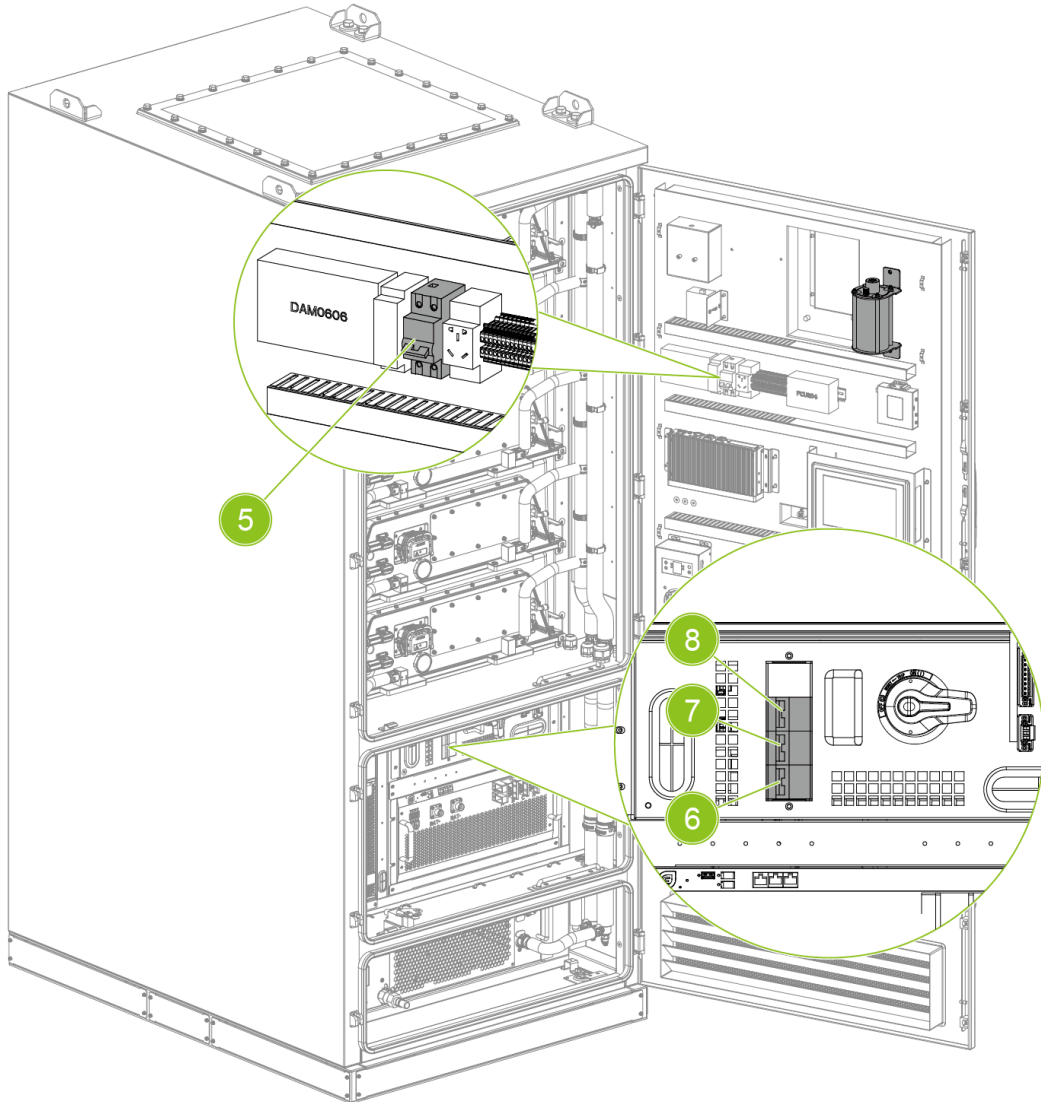

Fig. 7-9 Power off procedure

8. Troubleshooting

8.1. Alarms and Handling

8.1.1. LEMS Alarm Information

Alarm name	Alarm level	Fault reason	Handling suggestion
Cabinet-Level Aerosol Spray Alarm	Level 3	Aerosol spraying	Check the ignition source
Battery compartment temperature sensor alarm	Level 2	Temperature detector activated	Check the ignition source
Battery compartment smoke alarm	Level 2	Smoke detector activated	Check if there is any burning inside the cabinet
Fire level 1 alarm	Level 2	Combustible gas concentration $\geq 10\%LEL$ Smoke detector activated Temperature detector activated Any of the above conditions is met	<ul style="list-style-type: none"> • Check if it is a false alarm • Check for any combustible gas leakage • Check the temperature of the battery cell • Check if there is any burning inside the cabinet
Fire safety level 2 alarm	Level 3	Temperature sensor activation + combustible gas concentration $\geq 20\%LEL$	Check the ignition source

Alarm name	Alarm level	Fault reason	Handling suggestion
		Smoke detector and temperature sensor activate simultaneously	
PCS communication abnormality	Level 3	The network cable is loose PCS IP address setting error LEMS IP address setting error	<ul style="list-style-type: none"> • Check if the network cable connection is correct and if it is loose • Check if the LEMS IP settings are correct • Check if the PCS IP settings are correct
BMS communication exception	Level 3	The network cable is loose BMS IP address setting error LEMS IP address setting error	<ul style="list-style-type: none"> • Check if the network cable connection is correct and if it is loose • Check if the LEMS IP settings are correct • Check whether the BMS IP settings are correct
Communication abnormality of the gateway meter	Level 3	Wiring error LEMS communication configuration error Communication line interference	<ul style="list-style-type: none"> • Check whether the RS485 wiring is correct and whether it is loose • If the gateway meter adopts the DLT645 protocol, replacing the gateway meter requires modifying the LEMS communication configuration • If the gateway meter adopts the Modbus protocol, check the communication settings of the gateway meter • The communication line is subject to interference. The communication line should use shielded twisted pair, with one end of the shield

Alarm name	Alarm level	Fault reason	Handling suggestion
			grounded. When the distance is long, a 120 Ω resistor can be connected in parallel between the A and B lines at both ends
PV inverter communication abnormality	Level 2	Wiring error RS485 address setting error Communication line interference	<ul style="list-style-type: none"> • Check whether the RS485 wiring is correct and whether it is loose • Check the communication settings of the PV inverter • The communication line should use shielded twisted pair, with one end of the shielding layer grounded. When the distance is long, a 120 Ω resistor can be connected in parallel between the A and B wires at both ends.
LEMS black screen	Level 3	Power supply abnormality LEMS screen is frozen	<ul style="list-style-type: none"> • Check if the power supply is normal • Restart LEMS • Restart the LEMS. If the BIOS can be accessed but the desktop cannot be entered, replace the hard disk. • Restart the LEMS. If the BIOS cannot be accessed, replace the LEMS.

8.1.2. BMS Alarm Information

Alarm name	Alarm level	Fault reason	Handling suggestion
Single cell SOC high (mild)	Level 1	Prompt for high system capacity	No action required
Single cell SOC high (moderate)	Level 1	Full system reminder	No action required
Single cell or Battery PACK or Total voltage overvoltage (mild)	Level 1	Prompt for high system capacity	No action required
Single cell or Battery PACK or Total voltage overvoltage (moderate)	Level 1	Prompt for full system capacity	No action required
Single cell or Battery PACK or Total voltage overvoltage (severe)	Level 2	System communication abnormality PCS abnormality (no response to charge prohibition) BMS abnormality (charge prohibition not executed)	<ul style="list-style-type: none"> • Check PCS status • Check communication status between BMS and PCS
Single cell or Battery PACK or Total voltage	Level 1	System capacity low reminder	No action required

Alarm name	Alarm level	Fault reason	Handling suggestion
under-voltage (mild)			
Single cell or Battery PACK or Total voltage under-voltage (moderate)	Level 1	System capacity depletion reminder	No action required, need to pay attention to system strategy and recharge in time
Single cell or Battery PACK or Total voltage undervoltage (severe)	Level 2	System communication abnormality PCS abnormality (no response to discharge prohibition) BMS abnormality (discharge prohibition not executed)	<ul style="list-style-type: none"> • Check PCS status • Check communication status between BMS and PCS
Charging/discharging temperature high (mild)	Level 1	System battery cell temperature is slightly high	Check the working status of the liquid cooling unit
Charging/discharging temperature is low (mild)	Level 1	The temperature of the system battery cell is low	Check the working status of the liquid cooling unit
Charging/discharging temperature is high (moderate/severe)	Level 2	The temperature control system is abnormal or the battery cell is abnormal	<ul style="list-style-type: none"> • Check the working status of the liquid cooling unit • Check the battery status • Contact the manufacturer for repair
The charging/discharging	Level 2	The temperature control system is abnormal or the battery cell is abnormal	<ul style="list-style-type: none"> • Check the working status of the liquid cooling unit

Alarm name	Alarm level	Fault reason	Handling suggestion
temperature is low (moderate/severe)			<ul style="list-style-type: none"> • Check the battery status • Contact the manufacturer for repair
Charging prohibited	Level 1	System fully charged, charging prohibited alarm	No action required
Discharging prohibited	Level 1	System discharged, discharging prohibited alarm	No action required
ESBMM communication fault	Level 2	Battery PACK communication abnormal	<ul style="list-style-type: none"> • Check whether the communication harness between the battery PACKs is abnormal • Check whether the communication between the high voltage box and the battery PACK is abnormal • Restart the high voltage box • Contact the manufacturer for repair
Insulation resistance is slight/moderate/severe	Level 2	<p>There may be a leakage on the DC side of the system</p> <p>There may be insulation damage on the DC side of the system</p> <p>The humidity inside the system is too high</p>	<p>The system is completely powered off,</p> <ul style="list-style-type: none"> • Check DC cables • Check ambient humidity • Check the working status of the dehumidifier • Contact the manufacturer for repair
Combustible gas concentration low/high	Level 2	Combustible gas exists in the battery PACK	The system is completely powered off, contact the manufacturer for repair.

Alarm name	Alarm level	Fault reason	Handling suggestion
Fire level 1 alarm	Level 2	There is an abnormality inside the battery PACK.	Contact the manufacturer for assistance.
Fire safety level 2 alarm	Level 2	There may be a fire risk inside the battery PACK.	<ul style="list-style-type: none"> • Contact the manufacturer for assistance. • Cut off the AC source • Prepare fire extinguishing media (fire hydrant, etc.) • Contact the fire department for assistance
Intake valve/exhaust valve failure	Level 2	There is a foreign object in the intake valve/exhaust valve Intake valve/exhaust valve failure	<ul style="list-style-type: none"> • Check if there is any foreign object in the intake valve/exhaust valve. • Check if the intake valve/exhaust valve is abnormal. • Contact the manufacturer for repair or replacement
Dehumidifier communication lost	Level 2	Abnormal communication between the dehumidifier and BMS	<ul style="list-style-type: none"> • Check the status of the dehumidifier • Check the communication harness between the dehumidifier and BMS • Restart the system • Contact the manufacturer for repair
I/O device communication failure	Level 2	Abnormal communication between I/O device and BMS	<ul style="list-style-type: none"> • Check the status of the I/O device

Alarm name	Alarm level	Fault reason	Handling suggestion
			<ul style="list-style-type: none"> • Check the communication harness between the I/O device and BMS • Restart the system • Contact the manufacturer for repair
Liquid cooling unit communication lost	Level 2	Abnormal communication between liquid cooling unit and BMS	<ul style="list-style-type: none"> • Check the status of the liquid cooling unit • Check the communication harness between the liquid cooling unit and BMS • Restart the system • Contact the manufacturer for repair

8.2. BMS Troubleshooting

No.	Fault phenomenon	Solution
1	The ESMU does not work properly after powering on.	Record the observed phenomena and restart the power supply.
2	No data can be obtained on the display control screen.	Check whether the BMS cable is connected and whether the battery cluster IP address setting is incorrect.
3	The total voltage of a single battery cluster is too low, and the ESBMM has disconnected.	<ul style="list-style-type: none"> • Check if the 24V line of the ESBMM is correctly connected.

No.	Fault phenomenon	Solution
		<ul style="list-style-type: none"> • Replace the ESBMM module and check if the module returns to normal.
4	Abnormal voltage sampling of a single battery cell.	<ul style="list-style-type: none"> • Remove the battery PACK and check if the sampling fuse is blown. • Replace the ESBMM module and check if the module returns to normal.
5	ESBMM did not perform the balancing function.	<ul style="list-style-type: none"> • Remove the battery PACK and check if the sampling fuse is blown. • Replace the ESBMM module and check if the module returns to normal.
6	The display shows that the total cluster voltage is normal, but there is no current or three times the current during charging and discharging.	<ul style="list-style-type: none"> • Check whether the contact resistance of the cluster circuit has increased. • Check whether the battery PACK is tight. • Check whether the fuse at the DC busbar is damaged. • Check whether the internal resistance of the battery PACK increases and whether the voltage is within the normal range.

NOTICE!

If the BMS fault still cannot be resolved, please contact the after-sales service personnel.

8.3. Liquid Cooling Unit Troubleshooting



WARNING!

- The liquid cooling unit is a professional equipment and can only be operated by qualified authorized personnel.
- Before replacing major components, the power supply and communication must be disconnected first.
- The maintenance and replacement of all components can only be carried out by qualified personnel, and only approved materials, parts and components can be used for replacement.

Phenomenon	Possible reasons	Inspection items or handling methods
External circulation fan not running	Liquid cooling unit not powered	Check whether there is power at the power input terminal of the liquid cooling unit.
	Circuit breaker is tripped due to lightning stroke	Check whether the internal circuit breaker of the liquid cooling unit is closed.
	Abnormal power input of the liquid cooling unit (such as overvoltage or undervoltage)	Confirm whether there is a corresponding alarm in the liquid cooling unit, and if so, handle it according to the liquid cooling unit manual.
	Fan stuck	Check whether there is any foreign object stuck in the fan.
	Loose terminal	Check whether the fan docking terminal is loose.
	Compressor not started	Refer to the liquid cooling unit manual for the handling method when the compressor is not started.
	Control board failure	Replace the control board, refer to the liquid cooling unit manual to replace the control board

Phenomenon	Possible reasons	Inspection items or handling methods
	Fan failure	Replace the fan, refer to the liquid cooling unit manual to replace the external circulation fan
Abnormal noise from the external circulation fan	The fan bearing is worn	Replace the fan, refer to the liquid cooling unit manual to replace the fan.
	The fan blade scratches other objects	Check if there are cables or other objects interfering with the fan blades.
Compressor not started	It is not powered on (in standby state)	Check the main power switch and the operation display interface to see if it is already turned on.
	Loose circuit connection	Tighten the circuit connectors.
	Open circuit or short circuit	Check for open or short circuits and repair the main power supply.
	Converter failure	Replace the frequency converter.
	Control board damaged	Replace the control board, refer to the liquid cooling unit manual to replace the control board.
	Compressor motor failure	Replace the compressor
The compressor is not working.	No cooling demand.	Check the output status of the compressor's liquid outlet temperature on the display interface. Check whether the operation interface is in the cooling state.
	Shutdown delay.	The compressor has the shortest shutdown time under normal conditions. If the temperature rises to the starting point during this period, the compressor will still start with a delay.

Phenomenon	Possible reasons	Inspection items or handling methods
Exhaust pressure is high	Condenser is dirty and blocked	Clean the condenser using compressed air or a vacuum cleaner equipped with a brush head.
	The external circulation fan is not running	Refer to the table above.
The internal circulation water pump does not start	Power not turned on (standby)	Check the main power switch and the operation display interface to see if it is already turned on.
	Loose circuit connection	Tighten the circuit connectors.
	Water pump converter failure	Replace the water pump converter.
	Pump is in a self-protection state due to no coolant	Check if there is coolant in the circulation system, and if not, replenish it.
	Pump body failure	Replace the water pump. Refer to the liquid cooling unit manual to replace the water pump.
The electric heating tube is not working	No heating demand	Check whether the outlet temperature and heating set point are set reasonably.
	Loose circuit connection	Tighten the circuit connectors.
	Electric heating overheat protection	Wait for a period of time and then restart the electric heating, observe whether the electric heating is working normally.
	Electric heating fault	Replace the electric heating. Refer to the liquid cooling unit manual to replace the heater and circulation pump.
	Coolant refill pump failure	Replace the automatic coolant refill pump.

Phenomenon	Possible reasons	Inspection items or handling methods
The automatic coolant refill pump is not operating	The coolant refill pump is stuck	Check if there are any foreign objects in the coolant refill tank, and remove them if present. If the coolant refill pump is damaged, please replace it.
	Loose terminal	Check if the docking terminal of the coolant refill pump is loose.
Automatic coolant refill pump makes abnormal noise	Axial of the coolant refill pump is worn	Replace the automatic coolant refill pump.
	Fixing screws of the coolant refill pump is loose	Tighten the screws.

8.4. PCS Troubleshooting



DANGER!

There may be a risk of electric shock due to high voltage.

- Under fault conditions, the product may have high voltage. Touching the live parts of the equipment may lead to danger or death.
- Please follow all safety information when operating the product.
- When performing product maintenance, appropriate Personal Protective Equipment (PPE) must be worn.
- If you are still unable to resolve the issue through the following content, please contact the manufacturer.

PCS protection functions and warning information

Once a fault occurs, relevant fault information can be read through EMS. Before seeking service, users can perform self-inspection according to the prompts in the table below, analyze the cause of the fault, and find a solution. During self-inspection, please do not disassemble machine components. If the problem cannot be solved, please contact the agent or our company directly.

Fault reset methods are divided into automatic reset and manual reset.

Automatic reset fault refers to the system automatically clearing the fault at regular intervals after the fault occurs. If the fault condition is eliminated, the system exits the fault state; if the fault condition still exists, the fault is reported again. The number of automatic resets can be set by the function code. When the number of automatic resets is used up, the fault will no longer be automatically reset until the user manually resets the system, and the number of automatic resets is reloaded.

Manual reset fault requires shutting down through the power on/off register after the cause of the fault is eliminated, and the PCS can only resume operation through the reset register.

Table 8-1 PCS troubleshooting table

ID	Fault name	Trigger mechanism	Fault handling
1	EPO signal	External dry contact signal is abnormal Usage 1 (default): normally closed by default Closed: Normal Open: Fault. Usage 2 (customized): normally open by default Open: Normal Closed: Fault.	Power-off and restart the system
2	IGBT hardware overcurrent fault	IGBT OCP fault	Power-off and restart the system
3	Busbar hardware overvoltage fault	Busbar hardware voltage overvoltage	Power-off and restart the system
5	Power module wave-by-wave current limiting fault	Power module wave-by-wave current limiting	Power-off and restart the system

ID	Fault name	Trigger mechanism	Fault handling
6	Balancing circuit wave-by-wave current limiting fault	Balanced circuit wave-by-wave current limiting	Power-off and restart the system
17	24V power supply failure	Internal auxiliary power supply failure	Power-off and restart the system
18	Fan failure	Fan stall	The system can automatically reset when the fault is cleared and the power-on command is 1 (1 indicates ON, 0 indicates OFF).
19	Single board connection fault	Internal connection fault	Power-off and restart the system
23	Lightning arrester fault	External dry contact signal is abnormal	Power-off and restart the system
24	Inductor overtemperature fault	Inductor temperature is greater than the limit	The system can automatically reset when the fault is cleared and the power-on command is 1 (1 indicates ON, 0 indicates OFF).
25	IGBT module overtemperature	IGBT temperature is greater than the limit	The system can automatically reset when the fault is cleared and the power-on command is 1 (1 indicates ON, 0 indicates OFF).
26	Balancing circuit overtemperature fault	Balancing circuit temperature is greater than the limit	The system can automatically reset when the fault is cleared and the power-on command is 1 (1 indicates ON, 0 indicates OFF).
27	15V power supply fault	Internal auxiliary power supply failure	Power-off and restart the system

ID	Fault name	Trigger mechanism	Fault handling
28	External fire alarm fault	External dry contact signal is abnormal Usage 1 (default): normally closed by default Closed: Normal Open: Fault. Usage 2 (customized): normally open by default Open: Normal Closed: Fault.	Power-off and restart the system
29	External BMS dry contact fault	External dry contact signal is abnormal Usage 1 (default): normally closed by default Closed: Normal Open: Fault. Usage 2 (customized): normally open by default Open: Normal Closed: Fault.	It can automatically reset when the fault disappears.
31	Environment over-temperature fault	Environment temperature exceeds the limit	The system can automatically reset when the fault is cleared and the power-on command is 1 (1 indicates ON, 0 indicates OFF).

ID	Fault name	Trigger mechanism	Fault handling
33	Grid overvoltage fault 3-phase 3-wire: line voltage V_{ab} overvoltage. 3-phase 4-wire: phase voltage V_{an} overvoltage.	Grid voltage exceeds the limit	It can automatically reset when the fault disappears.
34	Grid overvoltage fault 3-phase 3-wire: line voltage V_{bc} overvoltage. 3-phase 4-wire: phase voltage V_{bn} overvoltage.	Grid voltage exceeds the limit	It can automatically reset when the fault disappears.
35	Grid overvoltage fault 3-phase 3-wire: line voltage V_{ca} overvoltage. 3-phase 4-wire: phase voltage V_{cn} overvoltage.	Grid voltage exceeds the limit	It can automatically reset when the fault disappears.
36	Grid undervoltage fault 3-phase 3-wire: line voltage V_{ab} undervoltage. 3-phase 4-wire: phase voltage V_{an} undervoltage.	Grid voltage is less than the limit	It can automatically reset when the fault disappears.
37	Grid undervoltage fault	Grid voltage is less than the limit	It can automatically reset when the fault disappears.

ID	Fault name	Trigger mechanism	Fault handling
	3-phase 3-wire: line voltage Vbc undervoltage. 3-phase 4-wire: phase voltage Vbn undervoltage.		
38	Grid undervoltage fault 3-phase 3-wire: line voltage Vca undervoltage. 3-phase 4-wire: phase voltage Vcn undervoltage.	Grid voltage is less than the limit	It can automatically reset when the fault disappears.
39	Grid overfrequency fault	Grid frequency exceeds the limit	It can automatically reset when the fault disappears.
40	Grid underfrequency fault	Grid frequency is below the limit	It can automatically reset when the fault disappears.
41	Grid phase sequence error fault	Grid phase sequence A, B, C reversed	Power-off and restart the system, change phase sequence
42	AC phase A overcurrent fault	AC phase A current exceeds the limit	The system can automatically reset when the fault is cleared and the power-on command is 1 (1 indicates ON, 0 indicates OFF).
43	AC phase B overcurrent fault	AC phase B current exceeds the limit	The system can automatically reset when the fault is cleared and the power-on command is 1 (1 indicates ON, 0 indicates OFF).
44	AC phase C overcurrent fault	AC phase C current exceeds the limit	The system can automatically reset when the fault is cleared and the power-on command is 1 (1 indicates ON, 0 indicates OFF).

ID	Fault name	Trigger mechanism	Fault handling
46	AC current imbalance fault	The difference in current between phases A/B/C of the three-phase three-wire system exceeds the limit.	The system can automatically reset when the fault is cleared and the power-on command is 1 (1 indicates ON, 0 indicates OFF).
48	Neutral line overcurrent fault.	The neutral line current of the module exceeds the limit.	The system can automatically reset when the fault is cleared and the power-on command is 1 (1 indicates ON, 0 indicates OFF).
49	Pre-charge bus overvoltage fault.	Bus voltage during startup exceeds the limit.	The system can automatically reset when the fault is cleared and the power-on command is 1 (1 indicates ON, 0 indicates OFF).
50	Precharge bus undervoltage fault	Bus voltage is less than the limit during startup	The system can automatically reset when the fault is cleared and the power-on command is 1 (1 indicates ON, 0 indicates OFF).
53	Bus overvoltage fault	Bus voltage is greater than the limit during operation	The system can automatically reset when the fault is cleared and the power-on command is 1 (1 indicates ON, 0 indicates OFF).
54	Bus under-voltage fault	The bus voltage during operation is less than the limit	The system can automatically reset when the fault is cleared and the power-on command is 1 (1 indicates ON, 0 indicates OFF).
55	Positive and negative bus imbalance fault	The voltage difference between the positive bus and the negative bus is greater than the limit	The system can automatically reset when the fault is cleared and the power-on command is 1 (1 indicates ON, 0 indicates OFF).
56	Battery undervoltage fault	Battery voltage is less than the limit	It can automatically reset when the fault disappears.

ID	Fault name	Trigger mechanism	Fault handling
58	Battery overvoltage fault	Battery voltage is greater than the limit value	It can automatically reset when the fault disappears.
59	DC pre-charge overcurrent fault	DC current is greater than the limit value during startup phase	The system can automatically reset when the fault is cleared and the power-on command is 1 (1 indicates ON, 0 indicates OFF).
60	DC overcurrent fault	The DC current during operation exceeds the limit	The system can automatically reset when the fault is cleared and the power-on command is 1 (1 indicates ON, 0 indicates OFF).
61	Balancing circuit software overcurrent fault	The current of the balancing circuit during operation exceeds the limit	The system can automatically reset when the fault is cleared and the power-on command is 1 (1 indicates ON, 0 indicates OFF).
64	Battery reverse connection fault	Battery voltage is less than the limit	It can automatically reset when the fault disappears.
65	AC pre-charging timeout fault	During charging, the predetermined value was not reached within the specified time.	The system can automatically reset when the fault is cleared and the power-on command is 1 (1 indicates ON, 0 indicates OFF).
66	AC pre-charging phase A overcurrent fault	Pre-charging phase module	The system can automatically reset when the fault is cleared and the power-on command is 1 (1 indicates ON, 0 indicates OFF).
67	AC pre-charging phase B overcurrent fault	Pre-charging phase module	The system can automatically reset when the fault is cleared and the power-on command is 1 (1 indicates ON, 0 indicates OFF).

ID	Fault name	Trigger mechanism	Fault handling
68	AC pre-charging C-phase overcurrent fault	Pre-charging phase module overcurrent	The system can automatically reset when the fault is cleared and the power-on command is 1 (1 indicates ON, 0 indicates OFF).
71	Leakage current fault	Leakage current exceeds the limit	Power-off and restart the system. It is recommended to check if the system connection is normal.
81	Control board RAM fault	Control board RAM chip read/write error	Contact the manufacturer
82	Control board EEPROM fault	EEPROM read/write error	Contact the manufacturer
83	Control board ADC zero drift too large fault	ADC analog sampling channel zero drift too large	Contact the manufacturer
84	Control board background communication protocol fault	Communication protocol mismatch between DSPs	Contact the manufacturer
85	Control board CAN communication protocol fault	The communication protocol between CAN does not match	Contact the manufacturer
86	Control board CPLD communication protocol failure	The versions of CPLD and DSP do not match	Contact the manufacturer
87	Control board DataLog data failure	Control board DataLog data failure	Contact the manufacturer
90	Software Firmware (FW) Mismatch Fault	Software Firmware (FW) Mismatch Fault	Contact the manufacturer
92	BMS Battery Status Fault	BMS Status	View BMS Status
93	STS communication failure	The system did not detect the STS signal	The system can automatically reset when the fault is cleared and the power-on command is 1

ID	Fault name	Trigger mechanism	Fault handling
			(1 indicates ON, 0 indicates OFF).
94	BMS communication failure	The system did not detect the BMS signal	The system can automatically reset when the fault is cleared and the power-on command is 1 (1 indicates ON, 0 indicates OFF).
95	Parallel system slave communication failure	The system did not detect the parallel signal	The system can automatically reset when the fault is cleared and the power-on command is 1 (1 indicates ON, 0 indicates OFF).
96	EMS communication failure	The system did not detect the EMS signal	The system can automatically reset when the fault is cleared and the power-on command is 1 (1 indicates ON, 0 indicates OFF).
97	Pre-charging switch closing failure	Pre-charging switch closing failure	The system can automatically reset when the fault is cleared and the power-on command is 1 (1 indicates ON, 0 indicates OFF).
98	Precharge switch disconnection fault	Precharge switch disconnection fault	The system can automatically reset when the fault is cleared and the power-on command is 1 (1 indicates ON, 0 indicates OFF).
99	Precharge switch closure status error	Precharge switch closure status error	The system can automatically reset when the fault is cleared and the power-on command is 1 (1 indicates ON, 0 indicates OFF).
100	Precharge switch disconnection status error	Precharge switch disconnection status error	The system can automatically reset when the fault is cleared and the power-on command is 1 (1 indicates ON, 0 indicates OFF).

ID	Fault name	Trigger mechanism	Fault handling
101	AC main switch closing fault	AC main switch closing fault	The system can automatically reset when the fault is cleared and the power-on command is 1 (1 indicates ON, 0 indicates OFF).
102	AC main switch opening fault	AC main switch opening fault	The system can automatically reset when the fault is cleared and the power-on command is 1 (1 indicates ON, 0 indicates OFF).
103	AC main switch closing status error	AC main switch closing status error	The system can automatically reset when the fault is cleared and the power-on command is 1 (1 indicates ON, 0 indicates OFF).
104	AC main switch disconnected state error	AC main switch disconnected state error	The system can automatically reset when the fault is cleared and the power-on command is 1 (1 indicates ON, 0 indicates OFF).
105	AC main switch adhesion fault	AC main switch adhesion fault	Do not power off, contact the manufacturer in time. If it has already been powered off, do not power it on again
106	DC main switch open circuit fault	DC main switch open circuit fault	Do not power off, contact the manufacturer in time
107	AC main switch open circuit fault	AC main switch open circuit fault	Do not power off, contact the manufacturer in time
113	Off-grid operation inverter overvoltage fault 3-phase 3-wire: line voltage V_{ab} overvoltage. 3-phase 4-wire: phase voltage V_{an} overvoltage.	Off-grid operation, inverter voltage exceeds the limit	The system can automatically reset when the fault is cleared and the power-on command is 1 (1 indicates ON, 0 indicates OFF).

ID	Fault name	Trigger mechanism	Fault handling
114	Off-grid operation inverter overvoltage fault 3-phase 3-wire: line voltage V_{bc} overvoltage. 3-phase 4-wire: phase voltage V_{bn} overvoltage.	Off-grid operation, inverter voltage exceeds the limit	The system can automatically reset when the fault is cleared and the power-on command is 1 (1 indicates ON, 0 indicates OFF).
115	Off-grid operation inverter overvoltage fault 3-phase 4-wire: line voltage V_{ca} overvoltage. 3-phase 4-wire: phase voltage V_{cn} overvoltage.	Off-grid operation, inverter voltage exceeds the limit	The system can automatically reset when the fault is cleared and the power-on command is 1 (1 indicates ON, 0 indicates OFF).
116	Grid islanding fault	Phase-locked frequency exceeds the limit	The system can automatically reset when the fault is cleared and the power-on command is 1 (1 indicates ON, 0 indicates OFF).
118	System resonance fault	AC filter capacitor current exceeds the limit	The system can automatically reset when the fault is cleared and the power-on command is 1 (1 indicates ON, 0 indicates OFF).
121	HVRT timeout fault	High voltage duration exceeds limit	The system can automatically reset when the fault is cleared and the power-on command is 1 (1 indicates ON, 0 indicates OFF).
122	Off-grid operation inverter voltage under-voltage fault	Off-grid operation, inverter voltage is less than limit	The system can automatically reset when the fault is cleared and the power-on command is 1 (1 indicates ON, 0 indicates OFF).

ID	Fault name	Trigger mechanism	Fault handling
	3-phase 3-wire: line voltage V_{ab} undervoltage. 3-phase 4-wire: phase voltage V_{an} undervoltage.		
123	Off-grid operation inverter voltage under-voltage fault 3-phase 3-wire: line voltage V_{bc} undervoltage. 3-phase 4-wire: phase voltage V_{bn} undervoltage.	Off-grid operation, inverter voltage is less than limit	The system can automatically reset when the fault is cleared and the power-on command is 1 (1 indicates ON, 0 indicates OFF).
124	Off-grid operation inverter voltage fault 3-phase 3-wire: line voltage V_{ca} undervoltage. 3-phase 4-wire: phase voltage V_{cn} undervoltage.	Off-grid operation, inverter voltage is less than limit	The system can automatically reset when the fault is cleared and the power-on command is 1 (1 indicates ON, 0 indicates OFF).
125	Off-grid mode no synchronization signal fault	Off-grid operation, phase-locked synchronization signal not detected	Do not power off, contact the manufacturer in time
127	Off-grid output short circuit fault	Off-grid operation, inverter voltage is less than the limit and output current is greater than the limit	Do not power off, contact the manufacturer in time
128	LVRT timeout fault	Low voltage duration exceeds the limit	The system can automatically reset when the fault is cleared and the power-on command is 1 (1 indicates ON, 0 indicates OFF).

8.5. Fire Product Troubleshooting

Phenomenon	Possible reasons	Inspection items or handling methods
Smoke detector false alarm or failure to trigger fire alarm	Detector is contaminated or damaged	Check if the detector is too dirty, return to the factory for repair or replacement
Temperature sensor false alarm or failure to trigger fire alarm	Detector damaged	Return to factory for repair or replacement
Combustible gas detector false alarm or failure to trigger combustible gas alarm	Detector damaged	Return to factory for repair or replacement

8.6. Dehumidifier Troubleshooting

After powering on, the dehumidifier enters the self-check state, after the self-check is completed, the dehumidifier enters the working state after 3 seconds, and the digital tube displays the humidity value of the box.

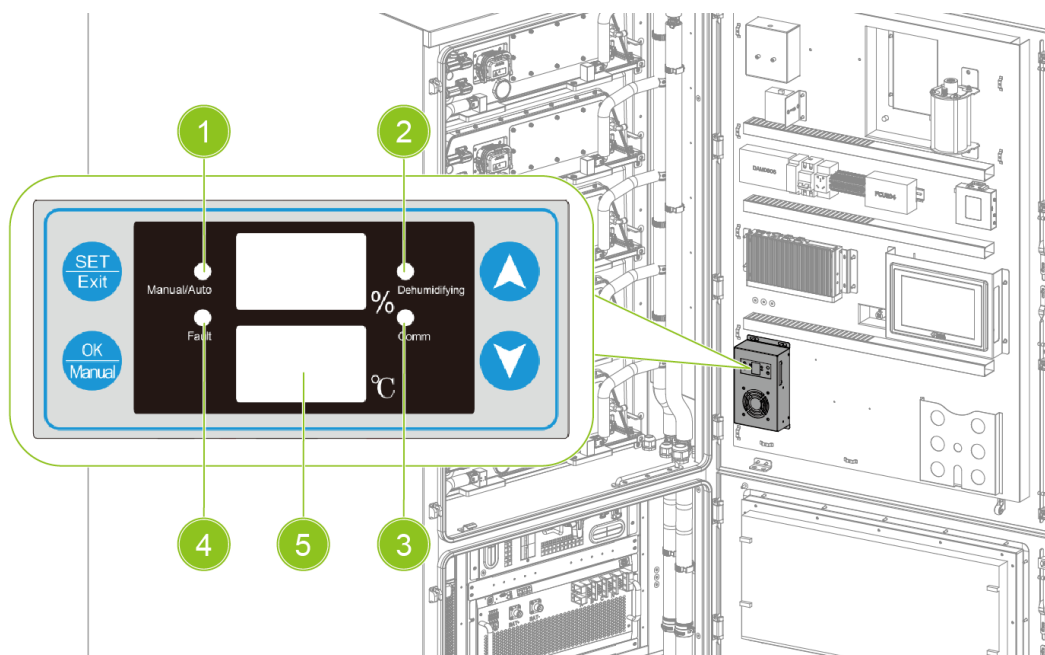

Fig. 8-1 Dehumidifier indicator

NO.	Indicator	Status	Description
1	Manual/Automatic	On	The dehumidifier is in manual operation mode.
		Off	The dehumidifier is in automatic operation mode.
2	Dehumidification	On	The dehumidifier is currently dehumidifying.
		Off	The dehumidification is complete.

3	Communication	On	It is currently receiving data from the host
4	Fault	On	A fault is occurring. If the humidity value shows "---", it indicates that a fault occurs in the humidity sensor or water droplets. If the temperature value shows "---", it indicates that a fault occurs in the temperature sensor
5	Fault code display area	/	/

If a fault code is displayed on the display, refer to the description of the fault codes as shown in the following table.

Fault code	Description
E2	External temperature sensor fault
E3	Cold surface temperature sensor fault
E4	Hot surface temperature sensor fault
E5	External ambient temperature too high
E6	Environment temperature too high

8.7. UPS Troubleshooting



For more information, please contact customer support.

9. Maintenance and Replacement

	<p>DANGER!</p> <p>Before conducting maintenance operations, please power off the equipment by referring to section 7.6 Power-off Procedure.</p>
---	--

	<p>NOTICE!</p> <p>The operation and maintenance of equipment such as battery PACK, liquid cooling unit, and fire safety system must be performed by qualified and authorized personnel. Some maintenance items require the system to be shut down first.</p>
---	---

If the system has been running for more than six months or has not been running for a long time, safety maintenance should be performed, and corresponding records should be made. The specific items are as follows:

- Check whether the safety door, front door, and battery compartment door of the equipment can be opened normally, and ensure that the environment inside and outside the equipment is clean and tidy.
- Check whether the fire extinguishing system can alarm and start normally, and whether there are firefighting device around the equipment for emergency use in case of an accident.
- Check whether the insulation of each power line is abnormal, whether the electrical safety gap meets safety standards, and whether the wiring bolts are loose.
- Check whether the electrical components are normal and whether the power doors of each power supply can be effectively disconnected.

9.1. Battery Maintenance

9.1.1. Battery Recharging

Recharging temperature requirement

Item	Requirement
Working temperature	-20°C~55°C
Optimal working environment temperature	20°C~40°C

Recharging steps

- Discharge the battery system to the cut-off condition (total voltage < 728V or minimum voltage < 2.8V), then stop discharging and let it stand for 1 hour.
- Fully charge the battery system (total voltage $\geq 936V$ or maximum cell voltage $\geq 3.6V$), and after charging, let it stand for 1 hour.

Recharging power requirement

The cell temperature should be above 0°C during recharging, and the recharging power should comply with the following charge and discharge map.



Cell temperature/°C	0	5	10	15	20	25	35	40	45	55	60	> 60
Max charging power (P)	0.05	0.12	0.25	0.33	0.5	0.5	0.5	0.5	0.5	0.5	0	0
Max discharging power (P)	0.3	0.3	0.4	0.5	0.5	0.5	0.5	0.5	0.5	0.5	0	\

9.1.2. Maintenance procedure

Maintenance frequency	Category	Maintenance content	Remarks
Quarter	Voltage Check	Check the battery system voltage through the monitoring system. Check if the system voltage is abnormal. For example: the voltage of a single battery PACK is too high or too low.	
	SOC check	Check the SOC of the battery system through the monitoring system. Check whether the SOC of the battery cluster is abnormal.	
	Cable check	Visually inspect all cables of the battery system. Check whether the cable is broken, aged, or loose.	
	Balancing check	Not fully charging for a long time will cause the battery PACK to become unbalanced. Solution: Perform balancing maintenance (charge to full) every 3 months, which is normally automatically completed by the system communicating with external devices.	

Maintenance frequency	Category	Maintenance content	Remarks
	Output relay check	Under low load conditions (low current), control the output relay OFF and ON, and hear the relay click, which means that the relay can be normally disconnected and connected.	
	Check of historical records	Analyze historical records, check whether there are accidents (alarms and protections), and analyze their causes.	
Semi-annual	Dust check	Keep the battery compartment clean.	
	Temperature	Measure and record the ambient temperature in the battery compartment.	
	Appearance	Check the appearance cleanliness of each battery. inspect the terminals and terminal covers for damage or signs of overheating.	
	Voltage	Check the battery system voltage through the monitoring system. Check whether the system voltage is abnormal. For example: the voltage of a single battery PACK is too high or too low.	
	Shutdown and maintenance	During the network management restart, some system functions need to be maintained. It is recommended to perform the following operations: maintain the system every 6 months.	
Annual	Repeat	Repeat quarterly maintenance and inspection.	
	Tightness check	Check whether the cable joints are loose every year and tighten them.	
	Discharge test	Perform a discharge test once a year to check the accurate load, with a discharge capacity of 30-40% of the rated capacity. After three years of operation, perform an 80% DOD capacity test once a year. Before the discharge test, the system should be fully charged.	

9.1.3. Replacement

	<p>DANGER!</p> <ul style="list-style-type: none"> • This Battery system is a high voltage DC system and can only be operated by qualified authorized personnel. • Before replacing major components, the main circuit of the maintenance battery cluster must be disconnected first. All component repairs and replacements can only be performed by qualified personnel, and only approved materials, components, and parts can be used for replacement.
	<p>WARNING!</p> <ul style="list-style-type: none"> • Different types of batteries, for example, batteries of different brands or rated capacities, are used together without prior approval from the Company. • Do not use a damaged battery (such as damage caused when a battery is dropped, bumped, bulged, or dented on the enclosure), because the damage may cause electrolyte leakage or flammable gas release. • Do not perform welding or grinding work around batteries to prevent fire caused by electric sparks or arcs. • If batteries are exposed to water accidentally, do not install them. Instead, transport the batteries to a safe isolation point and contact technical engineers in a timely manner.

Disassemble battery PACK

1. Power off the equipment, refer to 7.6 Power-off Procedure.
2. Remove the MSD (1) of faulty battery PACK in the reverse order of installation (refer to 5.6 MSD Installation).

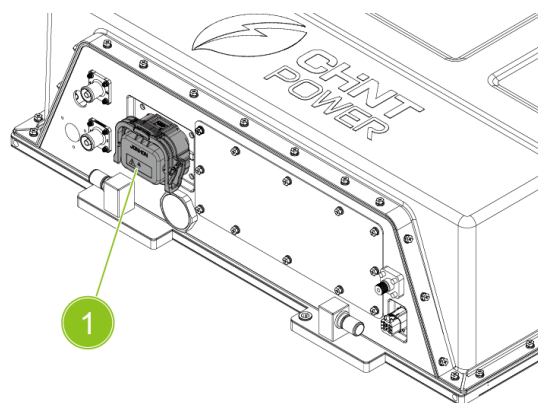

Fig. 9-1 Remove the MSD

3. Remove the 2 connectors (2) and communication cable (3) of faulty battery PACK.

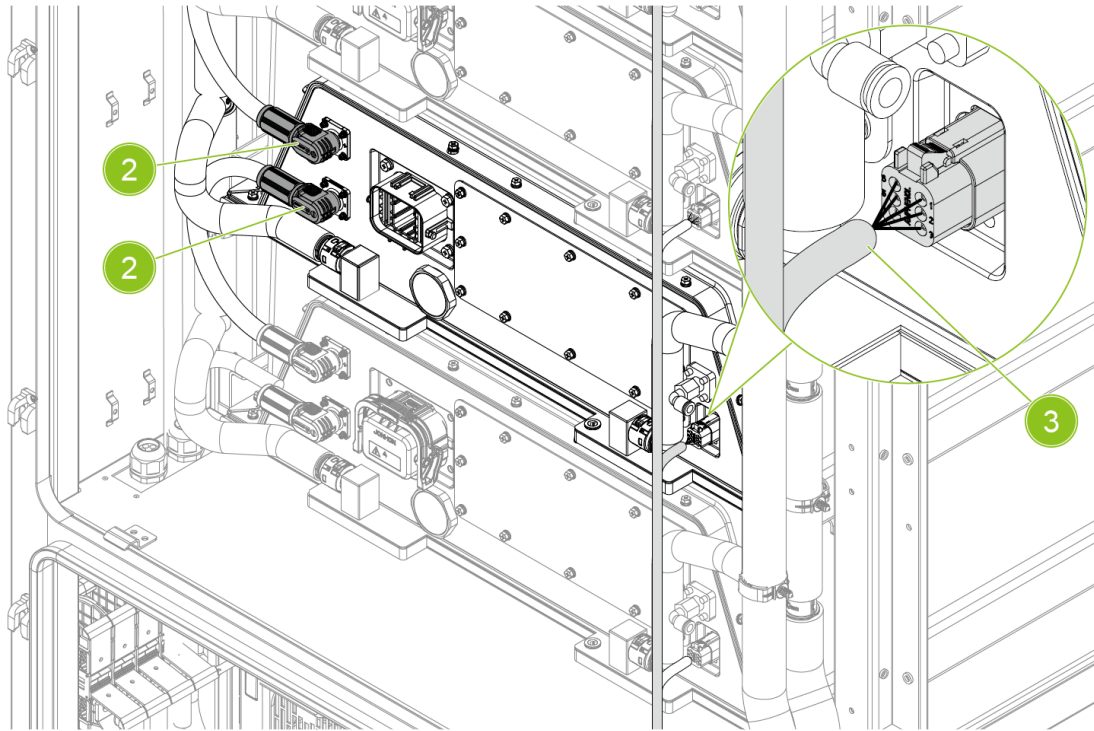

Fig. 9-2 Remove the connector and communication cable

4. Drain the coolant inside the pipes, refer to 9.2.1 Liquid Cooling Unit Replacement.
5. Remove coolant input pipe (4) and output pipe(5), drain the remaining coolant in the pipelines, and place the disassembled parts in the designated location.

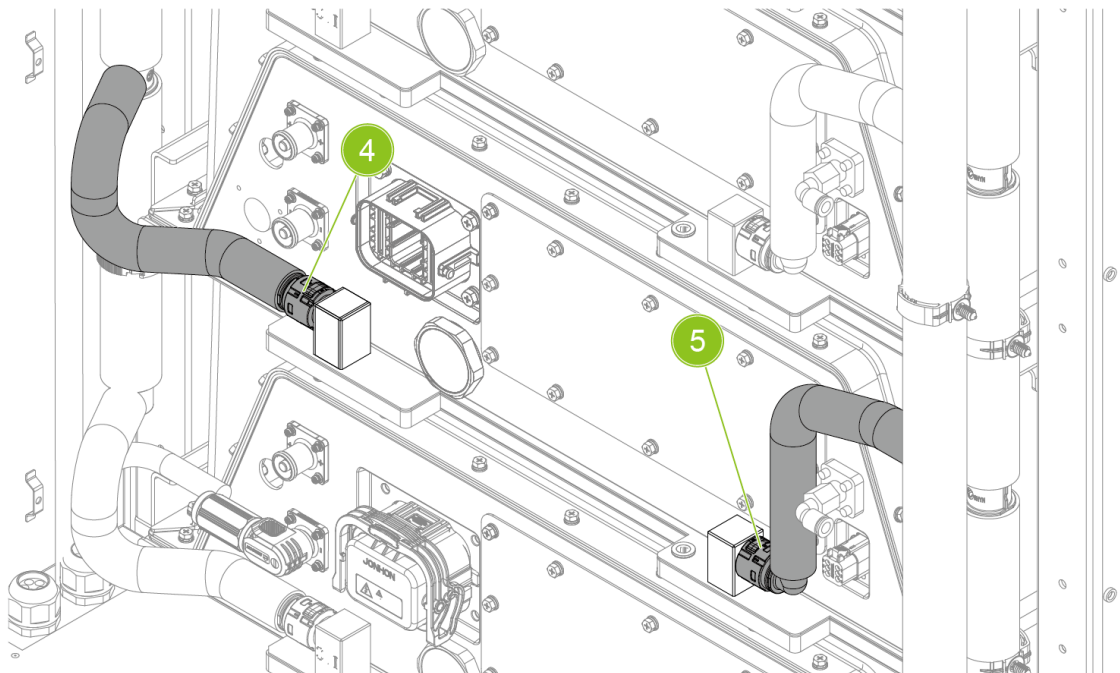

Fig. 9-3 Remove the coolant pipes

- Remove the 4 M8x20 combination screws (6) and 2 battery fixing tools (7) on the side beam of the battery rack.

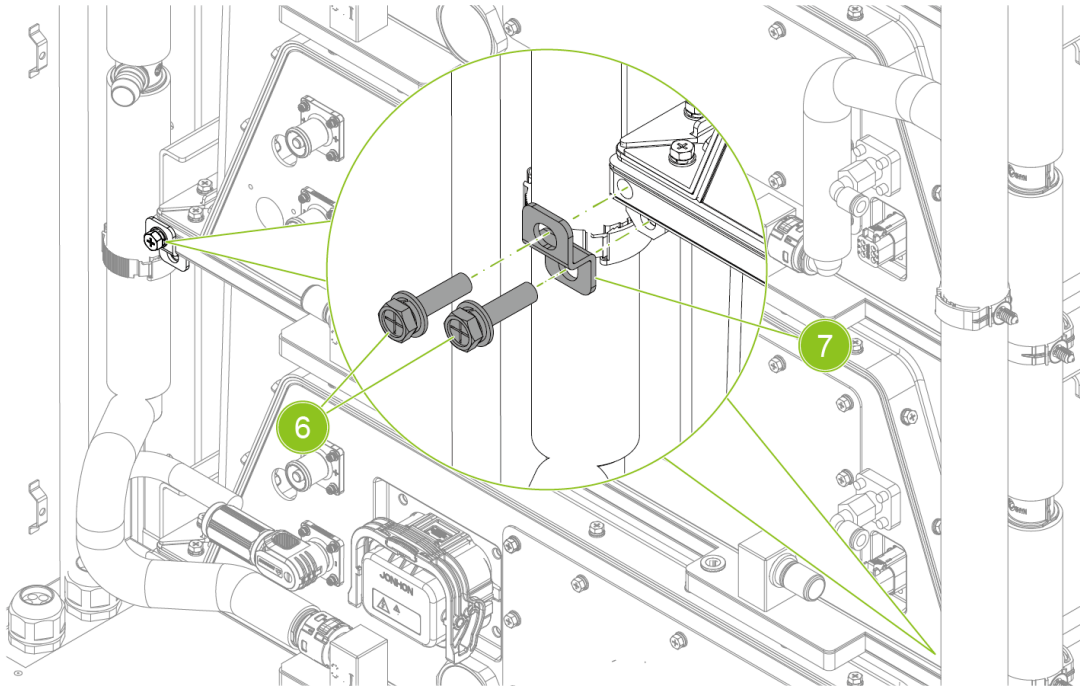

Fig. 9-4 Remove the battery fixing tools

- Install 2 eye bolts (8) and pull the battery PACK out of the battery rack for 50 cm.



DANGER!

- Single battery PACK is appr 400 kg.
- During handling process, please pay attention to personnel protection to prevent personnel injury or death from the battery PACK falling.

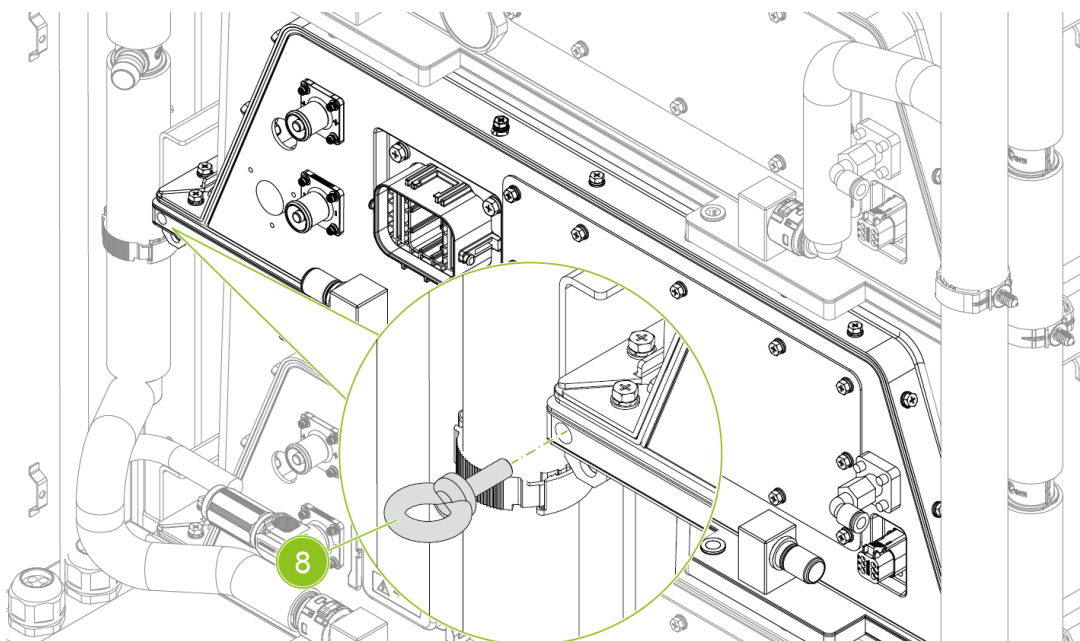

Fig. 9-5 Install eye bolts

8. Move the specialized forklift with a wheeled workbench (9) or platform to the bottom of the target battery PACK (10).

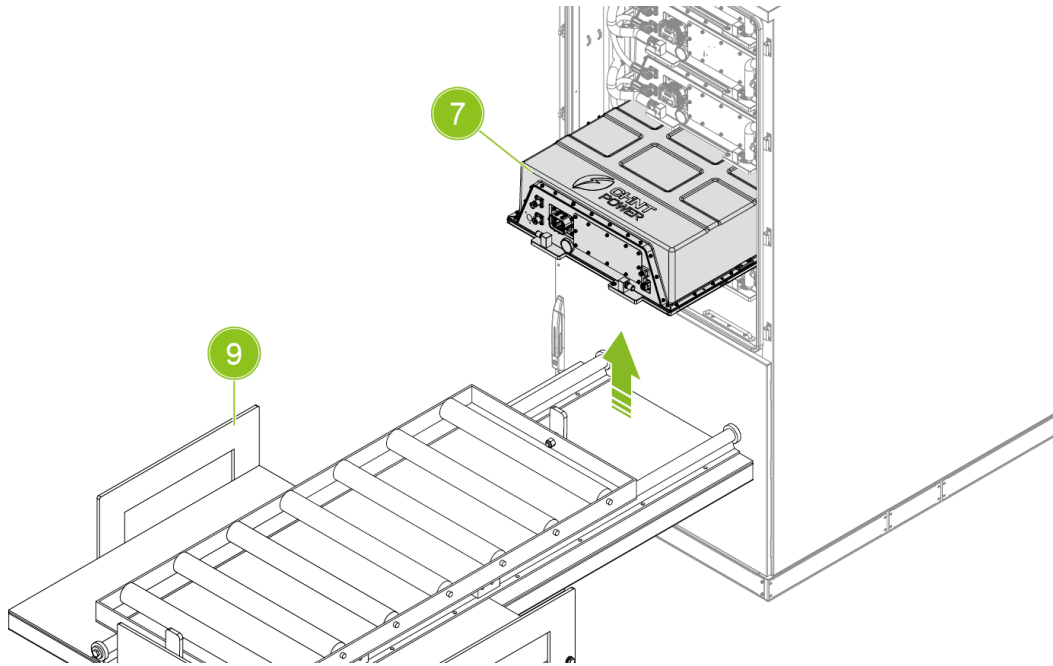

Fig. 9-6 Move out the battery PACK

9. Move the battery PACK onto the platform, and pull the battery PACK completely out of the rack.

Install the battery PACK



IMPORTANT!

Before installation, please carefully read the following precautions:

- Please confirm whether the battery PACK capacity matches the system: if it matches, replace it directly. if it does not match, consult a battery engineer.
- The disconnecter handle of the high voltage box should be in the "OFF" state.

1. Move the new battery PACK (1) to the installation position and push in the battery PACK.

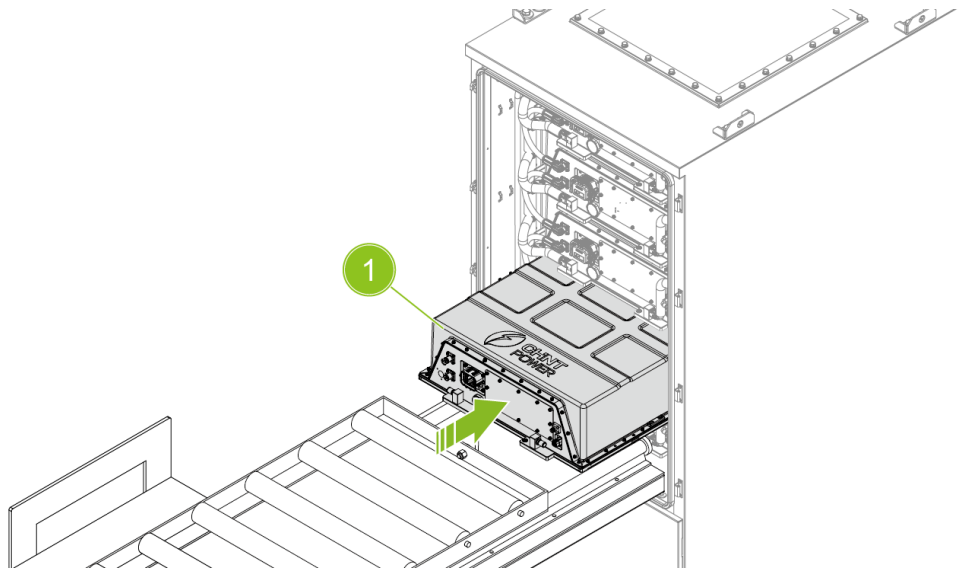

2. Install the 2 battery fixing tools (2) on the side beam of the battery rack, tighten the 4 M8x20 combination screws (3). Torque: 12.5 ± 1.3 N·m.

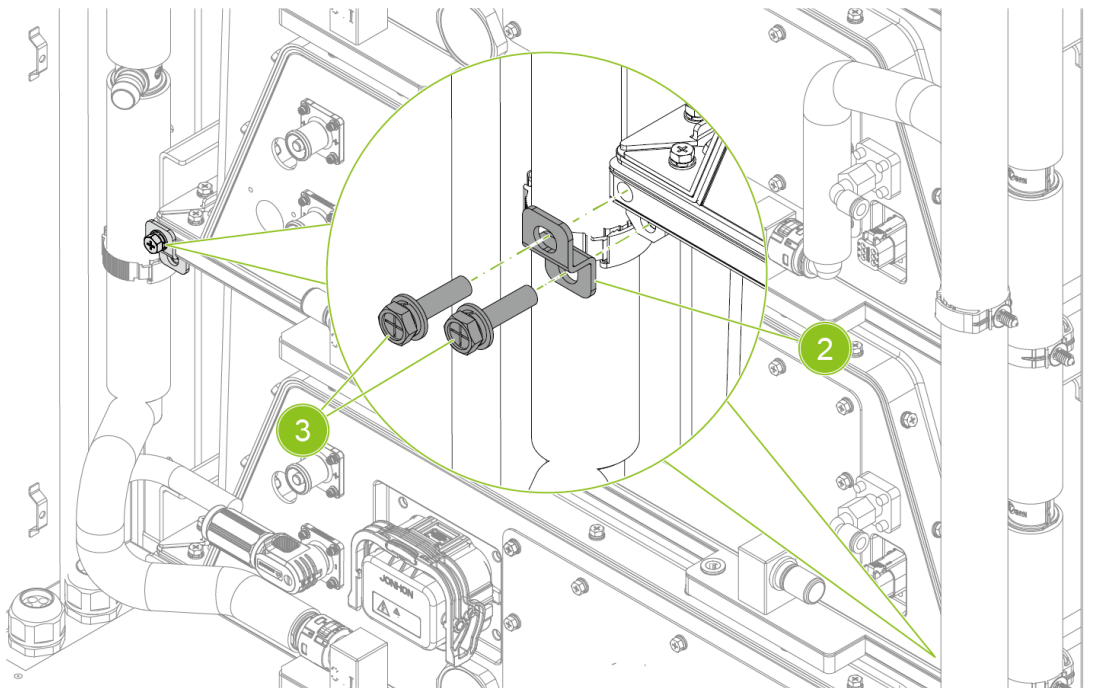

Fig. 9-7 Remove the battery fixing tools

3. Install the coolant input pipe (4) and output pipe(5).

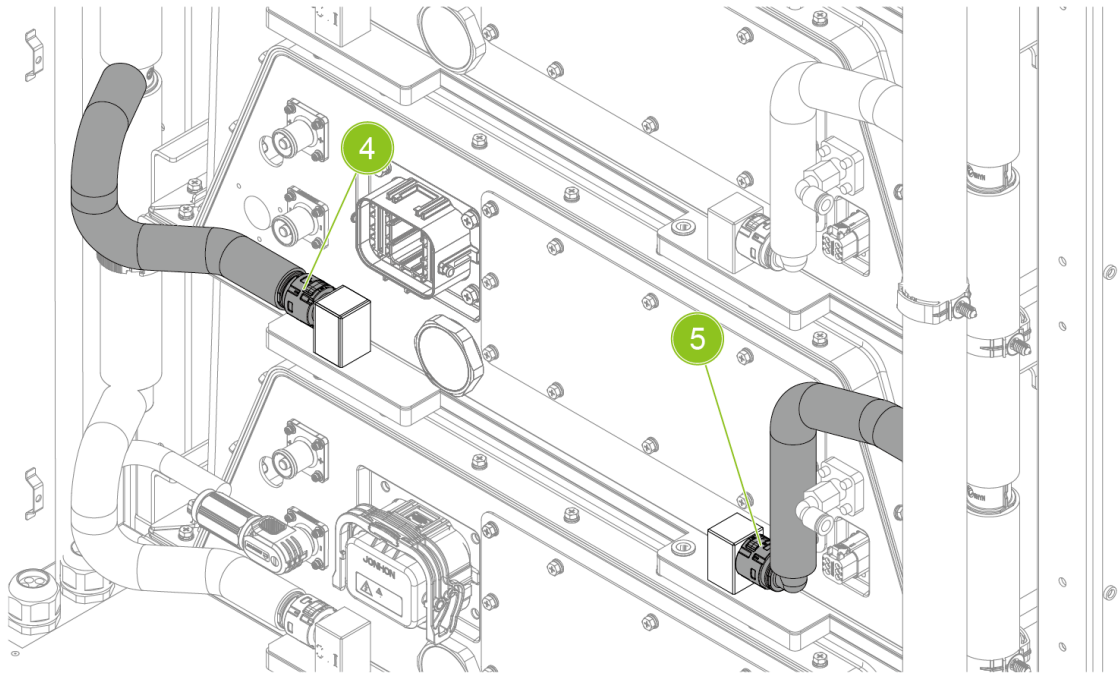

Fig. 9-8 Remove the coolant pipes

4. Install the 2 connectors (6) and communication connector (7) of faulty battery PACK.

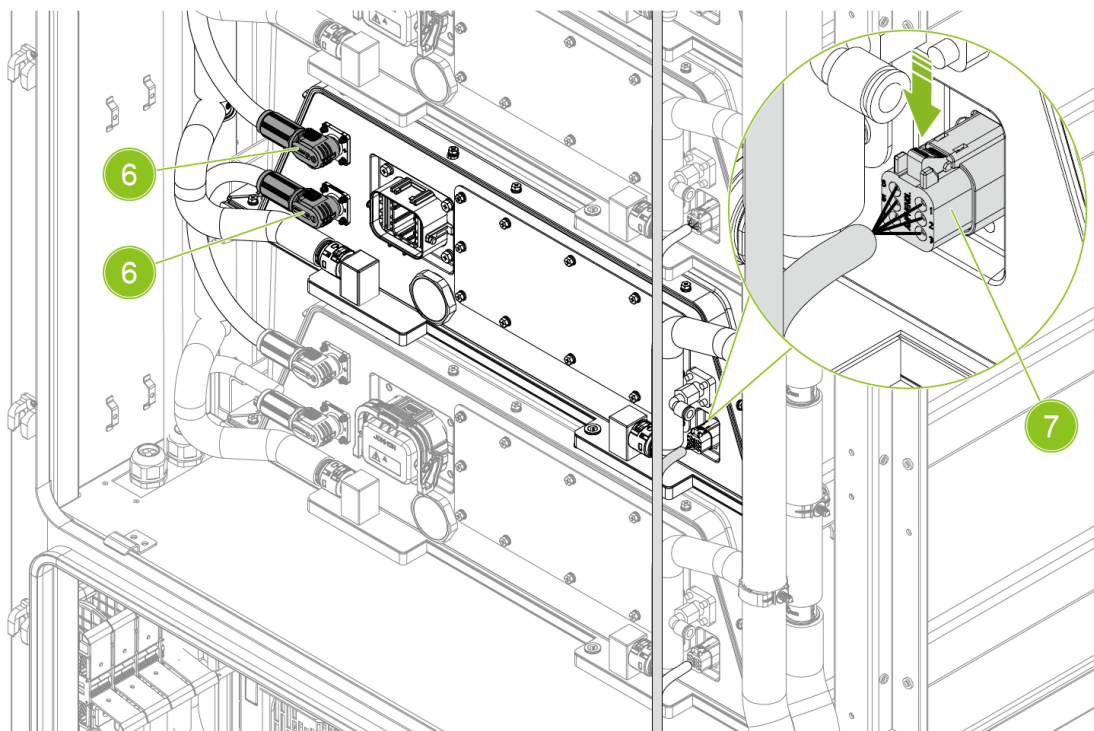

Fig. 9-9 Remove the connector and communication cable

5. Install the MSD (1), refer to 5.6 MSD Installation.

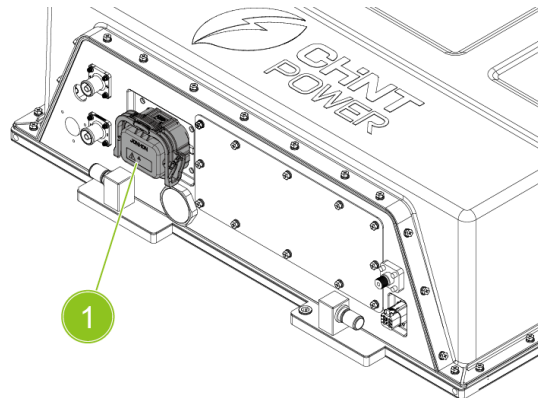

Fig. 9-10 Remove the MSD

6. Add coolant by referring to section 9.2.2 Liquid Replenishment After Equipment Replacement.

**NOTICE!**

After the new battery PACK is installed, the system needs to be powered on and then the status information of the target battery PACK should be confirmed through the display control interface to confirm whether the fault has been recovered or to proceed to the next step.

If there are other abnormal information, please contact professionals or the manufacturer for handling.

9.2. Liquid Cooling Unit Maintenance

9.2.1. Replacement

1. Power off the equipment by referring to 7.6 Power-off Procedure.
2. Prepare a coolant collection bucket (1), open the plug (2) at the bottom of the liquid cooling pipe,
3. Insert one end of the drain pipe into the bucket (1) and connect a drain pipe to the bottom end.



NOTICE!

- After the drainage pipeline is inserted, the coolant will immediately flow out.
- Please wear protective gloves to prevent the coolant from damaging your skin.

4. You can open the air exhaust plug (3) to speed the process of draining the coolant.

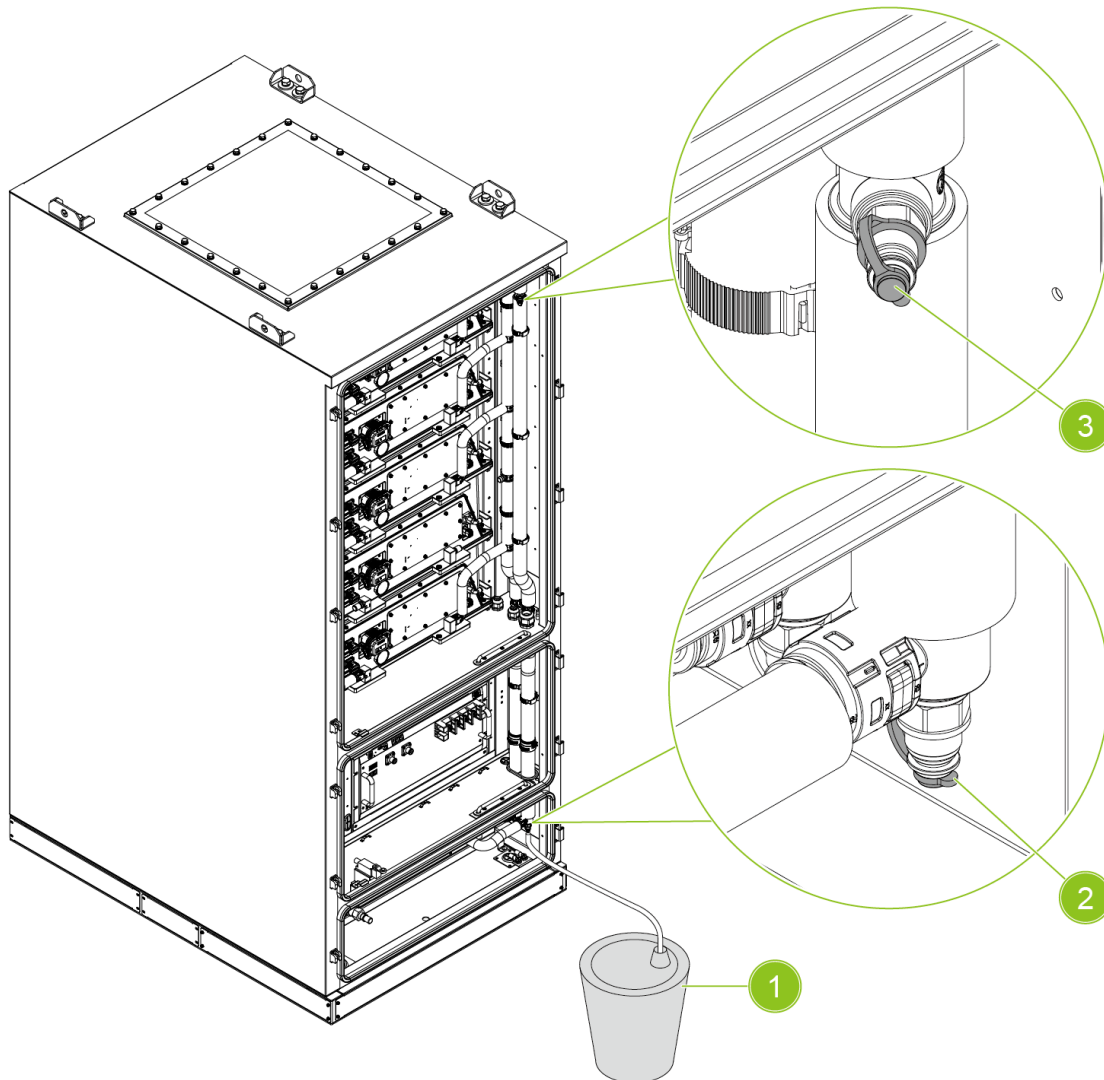

Fig. 9-11 Drain the coolant

5. If no coolant flows out in 30 seconds, remove the drain pipe and install the plug.
6. Disconnect the communication cable (4) and power supply cable (5) on the left side of the liquid cooling unit.



Fig. 9-12 Disconnect the communication cables

7. Remove the coolant inlet pipe (6) and outlet pipe (7).



Fig. 9-13 Remove the coolant inlet and outlet pipes

8. Remove the 4 combination screws.

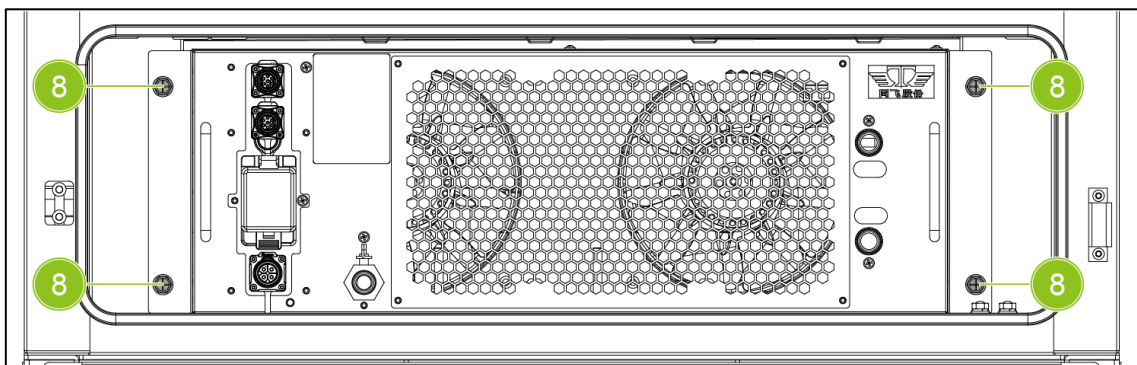

Fig. 9-14 Remove the combination screws

9. Hold the handles (9) and pull out the liquid cooling unit from the cabine.

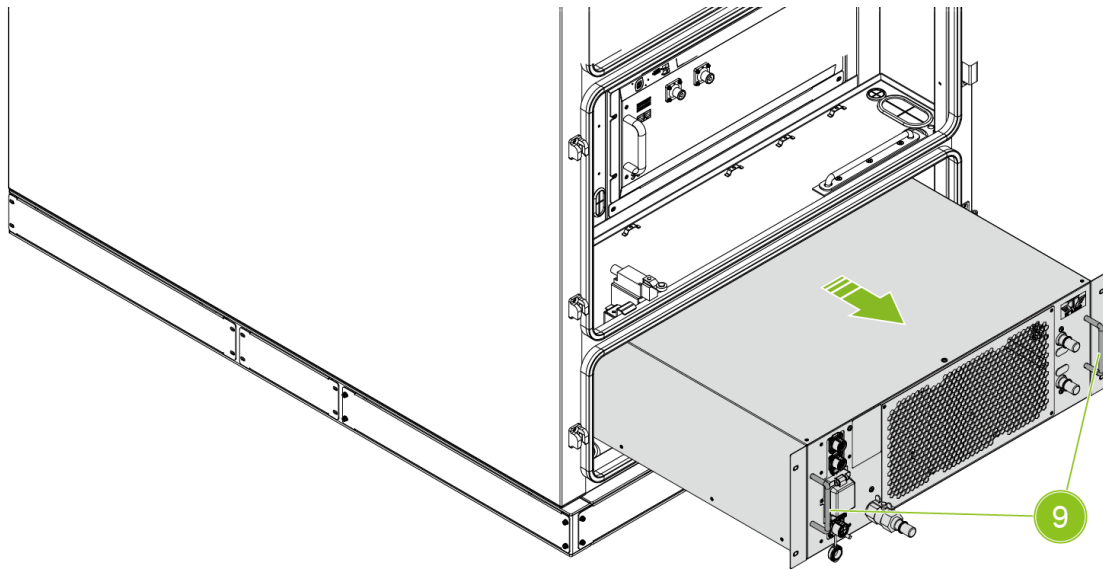

Fig. 9-15 Pull out the liquid cooling unit

10. Install the new liquid cooling unit in the reverse order of removing.



NOTICE!

Use a torque gun to fix the 4 combination screws in step 8.

Torque: 5.9 ± 0.2 N·m.

11. Perform the liquid replenishment operation on the connected system. For details on the liquid replenishment operation, refer to 9.2.2 Instructions for Liquid Replenishment After Equipment Replacement.

9.2.2. Liquid Replenishment After Equipment Replacement

When the liquid cooling unit has a low liquid level alarm, the liquid cooling system should be replenished in a timely manner.



NOTICE!

During the liquid replenishment operation, try to keep the unit running for a longer time. Even the vacuum-assisted liquid filling method requires the system to run for a longer period during the debugging phase to facilitate exhaust.

Steps

1. Connect the quick plug of the handheld display harness to the display interface (1) of the cooling system, and close the drain valve (2).



Fig. 9-16 Connect the quick plug and close the drain valve

2. Turn left to tighten and close the air exhaust valve on the cooling pipeline, refer to Fig. 9-7 Drain the coolant.
3. Connect the external power supply plug of the cooling system, refer to Fig. 9-8 Disconnect the communication cables to find the power supply plug.
4. First, power on the handheld display, then click  on the screen.



Fig. 9-17 Screen capture

5. One person holds the display screen to monitor the return water pressure value. When the return water pressure value reaches 2.5 bar, notify the colleague responsible for the air circuit connection to disconnect the air injection tube at the drain port (if the return water pressure value exceeds 2.5 bar, the pressure can be adjusted by slightly opening the drain port switch).

- After completing the air injection, record the current time. After maintaining the pressure for 15 minutes, observe the decay range of the return water pressure value. A decay value of less than 0.3 bar is considered qualified (i.e., not lower than 2.2 bar). Record the airtight test data in the registration form (both the set value and the actual value need to be recorded).



Fig. 9-18 Screen capture

- After the airtight test is completed, slightly open the drain port to expel the gas in the pipeline in preparation for vacuuming. When the return water pressure value is observed to be 0, it indicates that the gas expulsion is complete.

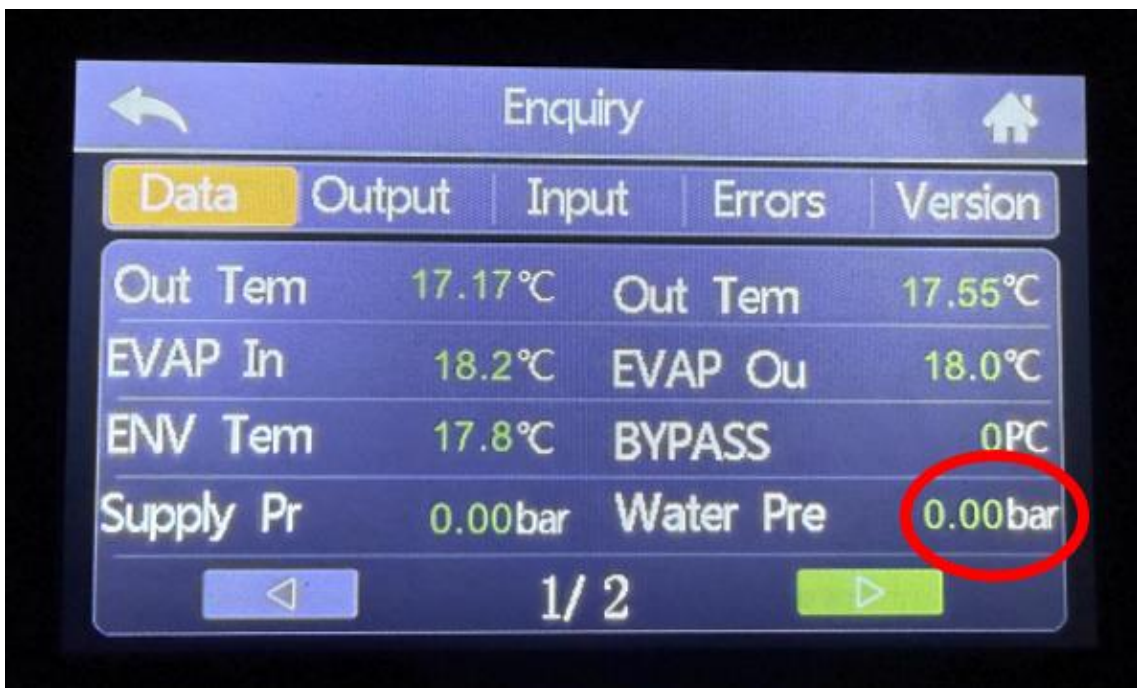

Fig. 9-19 Screen capture



Fig. 9-20 Return water pressure

8. Connect the pipeline of the filling equipment to the filling port, and use the pipeline drain valve to discharge the air in the pipeline.



Fig. 9-21 Connect the pipeline of the filling equipment

9. While filling, exhaust simultaneously. Use a common 8mm transparent PU air tube inserted into the exhaust return valve to conduct. Place the other end of the return tube in the coolant container, start the circulation pump to circulate the coolant carrying free bubbles back into the container to complete the gas-liquid separator, and then inject it into the system by the filling pump, repeating this cycle.



Fig. 9-22 Circulate the coolant carrying free bubbles back into the container

10. After starting the cooling system pump in manual mode, observe the supply and return water pressure under dynamic conditions. The pressure difference must be greater than 0.3 bar (maximum not exceeding 1 bar) when the pump is running dynamically to be qualified: Pressure calculation: Supply pressure - Return pressure > 0.3 bar.
11. If the pressure difference is less than 0.3 bar, run the pump for one minute and then turn it off, open the exhaust valve to vent, observe the static supply and return water pressure while venting, close the exhaust valve after venting is completed, and then run the pump for one minute, repeating this cycle until the dynamic pressure difference is greater than 0.3 bar.

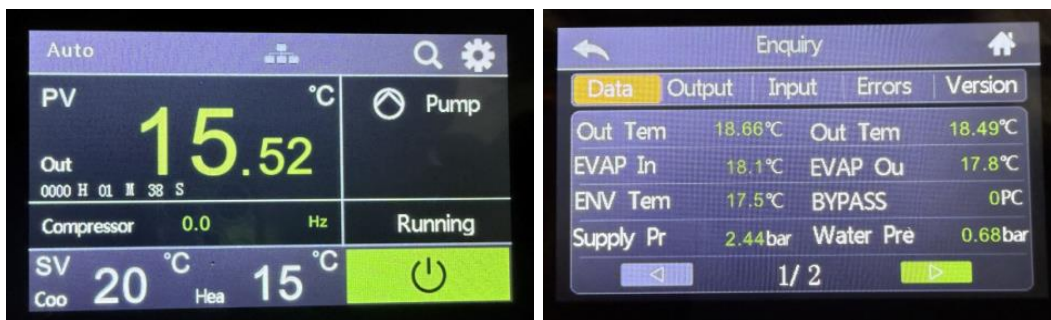

Fig. 9-23 Screen capture

12. In manual mode, after starting the cooling system pump for one minute, the refrigeration compressor and fan will automatically start, which is normal. After the pump has been running for one minute,

turn off the pump, open the exhaust valve, and observe the static pressure of the supply and return water (as shown in the figure below). The static pressure ranging from 0.6 bar to 1.2 bar (rounded to one decimal place) is normal. It is recommended to take the midpoint value. The maximum must not exceed 1.3 bar; otherwise, excess coolant must be drained through the drain port.

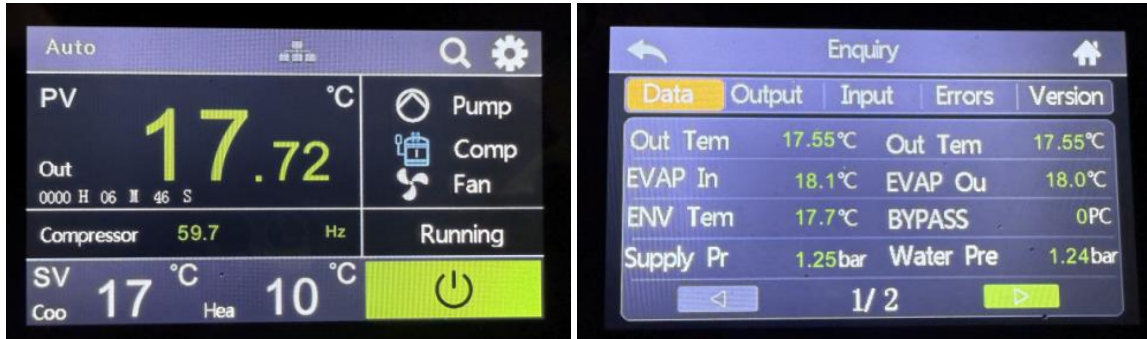

Fig. 9-24 Screen capture

13. Disconnect the power strip, remove the external power cable harness and restore the original harness, remove the handheld display and cover the protective cover.

9.2.3. Normal Liquid Replenishment

1. Use a pipeline to connect the liquid outlet of the replenishment pump to the liquid replenishment port of the liquid cooling unit, and connect the liquid inlet to the external liquid storage tank.
2. Connect the power cord of the replenishment pump, power on the liquid cooling unit.
3. After opening the replenishment ball valve, start the replenishment pump to inject coolant.
4. Observe the return liquid pressure.
 - End the injection when the return liquid pressure is stable between 0.8 bar ~ 1 bar.
 - When the return liquid pressure is below 0.8 bar, continue to use the replenishment pump to inject coolant for pressurization.
5. After the injection is completed, close the ball valve behind the replenishment port and then remove the replenishment pump.

9.3. Fire Safety System Maintenance

9.3.1. Maintenance Procedure

Table 9-2 Fire safety system maintenance procedure

Frequency	Category	Maintenance content	Remarks
Daily	Signboard Inspection	Check the warning signs in the protective area, including the warning signs for the manual pull starter, emergency stop switch, and manual-automatic transfer switch (emergency maintenance switch), to ensure they are in their original positions, securely installed, and not damaged.	
Monthly	Repeat	Repeat the contents of daily maintenance and inspection.	
	Equipment Sealing	Check whether all equipment maintaining the sealing of the protection area is intact, and linkage tests for linkage equipment such as fire dampers should be conducted every six months.	
Semi-annual	General inspection of aerosol devices	Check for any deformation, rust, aging, etc. on the appearance. Check whether the installation is secure.	
	Various detectors and alarms	Check if the working status is normal	
	All firefighting equipment	Ensure there are no changes that affect equipment performance. Check for changes in usage, environmental conditions, equipment location, physical obstructions, equipment orientation, physical damage, and cleanliness.	
Annual	Repeat	Repeat monthly maintenance and inspection.	
	Comprehensive inspection of aerosol devices	Inspect the structure of the battery compartment protected by the aerosol fire extinguishing system to determine whether any adverse effects such as fire extinguishing agent leakage or changes in the protected volume have occurred.	

Frequency	Category	Maintenance content	Remarks
	Integrity of the protected area	Investigate whether the protected area matches the originally designed system protection area and whether the integrity of the protected area has been compromised.	
	Actuator	Check whether the functions of the electromagnetic actuator and mechanical actuator are intact.	
	Detector	Check all detectors to ensure they are in their proper positions, clean, and undamaged. Each detector should be tested according to the commissioning requirements. If necessary, test the sensitivity of each detector according to the manufacturer's procedures.	
	Each warning device	Check each buzzer, flashing light, and alarm bell. Check the alarm status and verify that they operate correctly when powered on. Reset the alarm circuit after testing each alarm device.	

9.3.2. Component Replacement

Fire safety system consists of smoke detector, temperature sensor and combustible gas detector.



NOTICE!

Before replacing the fire system equipment, power off the equipment by referring to 7.6 Power-off Procedure.

Smoke detector replacement

1. Record the cable connection position on the smoke detector (1), then remove the cable terminal..

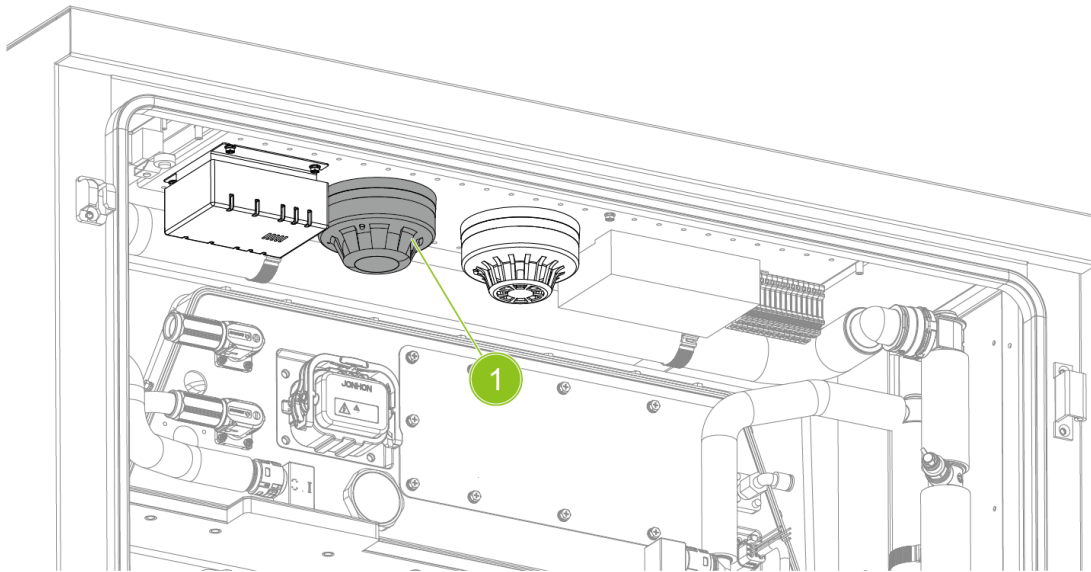

Fig. 9-25 Smoke detector installation position

2. Hold the smoke detector (1) and rotate it counterclockwise to separate it from the base (2).

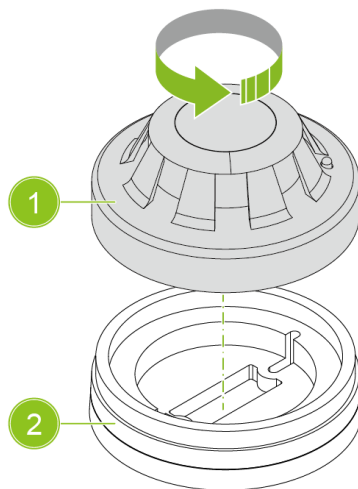

Fig. 9-26 Smoke detector installation position

3. Replace the new smoke detector and rotate it clockwise until it locks into place.
4. Connect the cable terminals to the new smoke detector according to the recorded information.

Replace the Temperature Sensor

1. Record the cable connection position on the temperature detector (1), then remove the cable terminals.

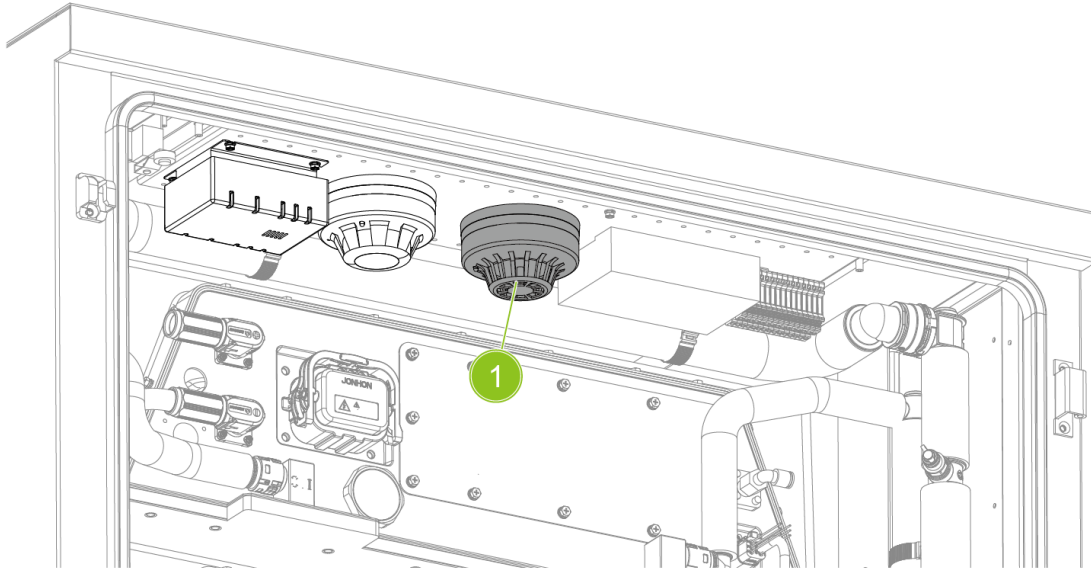

Fig. 9-27 Temperature sensor installation position

- 2.
3. Hold the temperature sensor (1) and rotate it counterclockwise to separate it from the base (2).

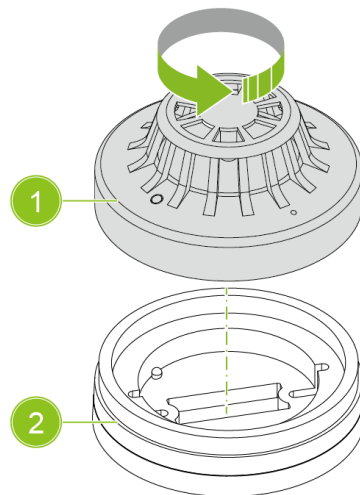

Fig. 9-28 Remove temperature sensor

4. Replace the new temperature sensor, rotate the sensor clockwise until it locks into place.
5. Connect the cable terminals to the new temperature sensor according to the recorded information.

Replace the Combustible Gas Detector

1. Record the cable connection positions on the combustible gas detector (1), then remove the cable terminals.

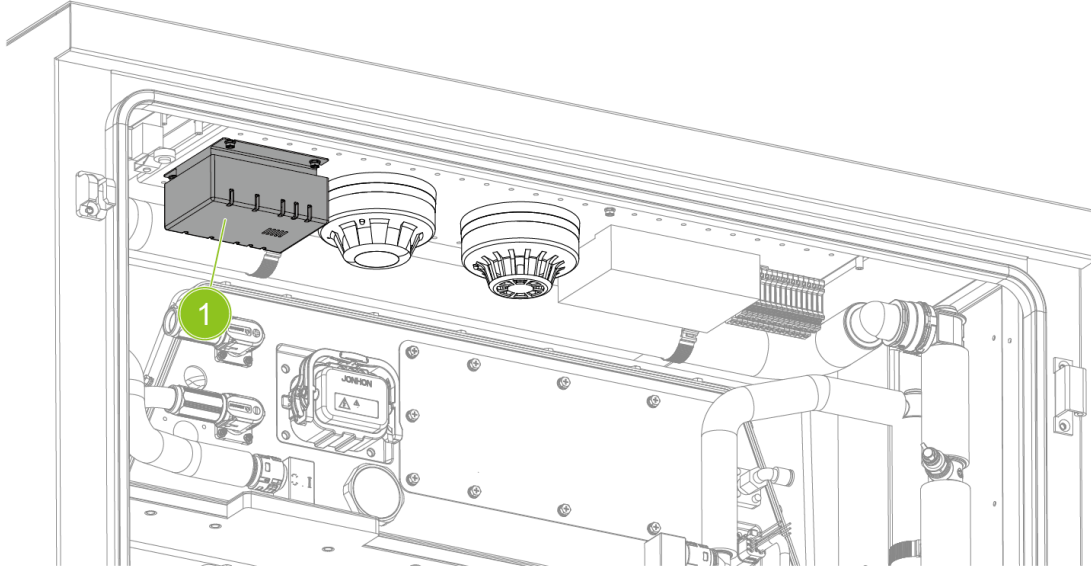

Fig. 9-29 Combustible gas installation location

2. Hold the combustible gas detector, use a torque gun to remove the fixing screws of the combustible gas detector, and separate it from the base.
3. Remove the 4 M4x10 combination screws (2) of the combustible gas detector.

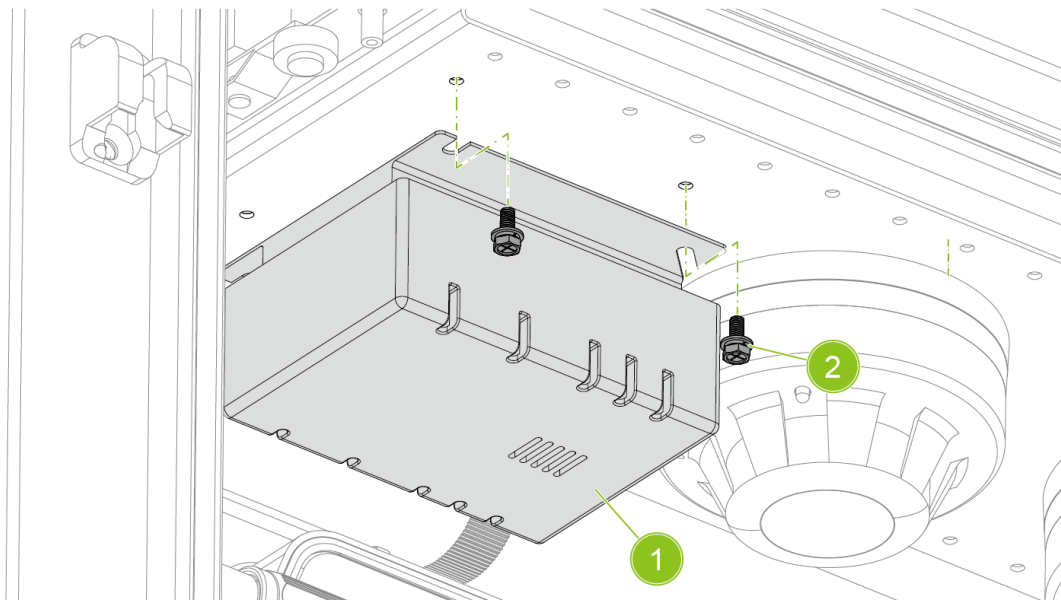

Fig. 9-30 Remove the fixing screws of the combustible gas detector

- Replace the new combustible gas detector, and use a torque gun to secure the fixing screws of the combustible gas detector.

Torque: 1.6 Nm

- Connect the cable terminals to the new combustible gas detector according to the recorded information.

Replace the Fire Extinguishing Device

- Record the cable connection positions on the fire extinguishing device, and then remove the cables.
- Loosen the two combination screws (1), remove the old fire extinguishing device (2).

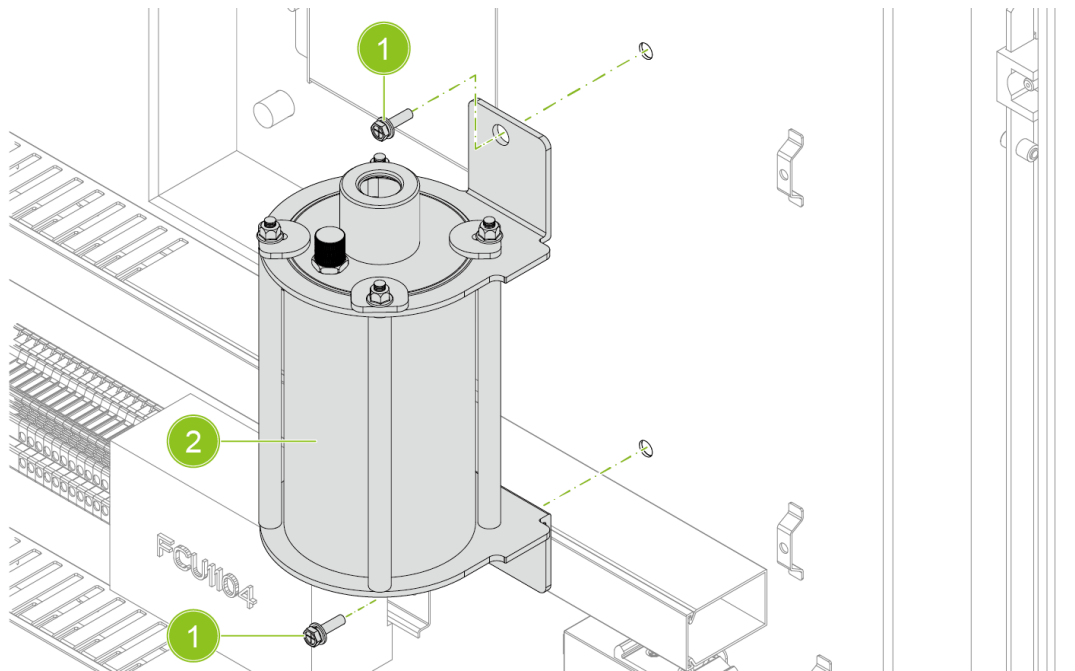

Fig. 9-31 Remove fire extinguishing device

- Install the new fire extinguishing device in the reverse order of disassembly.





NOTICE!

Use a torque gun to fix the combination screws in step 3.

Torque: $12.5 \pm 1.3 \text{ N}\cdot\text{m}$.

- Install the cables to the new fire extinguishing device according to the recorded information.

9.4. PCS Maintenance

	<p>DANGER!</p> <p>There is high voltage in the live parts of the PCS. Touching live parts may result in death or severe electric shock damage.</p> <p>Wear appropriate Personal Protective Equipment (PPE) during maintenance.</p>
	<p>IMPORTANT!</p> <ul style="list-style-type: none"> • Review all warning messages in the product and documentation. • Please comply with all safety information provided by the battery manufacturer.

- Before performing any operations on the PCS, be sure to disconnect the external power supply equipment from the PCS:
 - Grid voltage of the grid feed
 - Internal power supply
 - Direct Current (DC) voltage of the battery
 - Additional external voltage, such as control signals from the control room.
- Ensure that disconnected devices cannot automatically reconnect.
- After turning off the device, wait at least 5 minutes before turning it on again to allow the capacitors to fully discharge.
- Before operating, ensure that all components are completely free of voltage.
- Cover or isolate any adjacent live components.
- More frequent maintenance may be required, with the specific maintenance frequency depending on the on-site conditions.
- If the DC distribution components are susceptible to harsh environmental conditions, it is recommended to shorten the maintenance intervals.
- It is recommended to conduct regular visual inspections to determine whether maintenance is required.
- If the PCS has not been in operation for an extended period (more than 6 months), an EEPROM fault may occur during the first power-up. Such faults can be cleared by following the steps below:
 - Disconnect all power connections to the PCS.
 - Wait for at least 30 seconds.
 - Reconnect the power supply and power on. This process can reinitialize the device, thereby clearing the EEPROM fault.

- For converters that have not been in operation for a long time, it is recommended to perform a capacitor activation operation before putting them back into use to ensure the normal operation of the equipment. The steps for capacitor activation are as follows:
 - Start the converter.
 - Issue a charging power command of 1kW.
 - Let the PCS operate at this power for 30 minutes.
- This operation helps restore the performance of the capacitor and ensures stable operation of the PCS.

9.4.1. Maintenance Procedure

Daily inspection items should follow the key points below:

Table 9-4 Daily inspection items

No.	Daily Inspection Items	Confirm
1	The input and output voltage and current of the PCS, as well as its operating status, need to be monitored in real-time. Designated personnel should observe at fixed points. If any abnormalities in the converter's operation or voltage/current are detected, timely maintenance should be performed.	
2	Listen to the PCS for any abnormal noises.	
3	No abnormal odor is detected inside the PCS.	
4	Read the internal temperature of the PCS and observe that the temperature is within the normal range.	

Regular Inspection Items

The quarterly inspection every three months mainly focuses on areas that are difficult to inspect during daily checks and routine operations.

Table 9-5 Regular inspection items

No.	Regular Inspection Items	Confirm
1	Check the appearance of the PCS for no damage or rust.	
2	Use a temperature measuring instrument to detect that the internal temperature of the PCS is normal.	
3	Check that the ventilation, ambient temperature, humidity, dust, and other environmental conditions around the PCS meet the requirements.	
4	Check for aging or damage in the cable insulation layer. If found, add corresponding insulation measures or replace the cable.	

5	Check the wiring bolts for signs of aging or burning, and manually shake them to confirm they are in a tightened state.	
---	---	--

After maintenance is completed, check against the maintenance checklist one by one to ensure no maintenance items are missed. Confirm that the above maintenance process is correct, and this maintenance is completed.

9.4.2. Replacement



DANGER!

Before replacing the PCS, please confirm the following items:

- The system AC circuit breaker is turned off
- The system DC switch is turned off

Step

1. Find the PCS, the PCS location is shown in Fig. 2-5 System Annotation
2. As shown in the figure below, remove the PCS external DC cables (1), communication network cables (2), control cables (3), AC cables (4), grounding wires (5), etc..

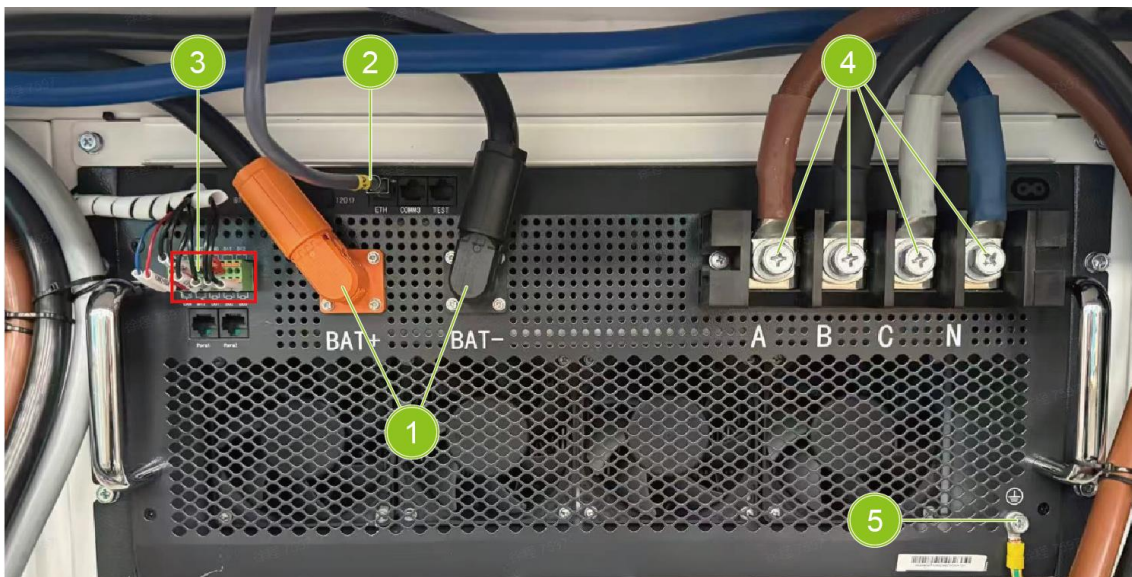

Fig. 9-32 Remove the external connection lines of the PCS

3. Use a No. 2 screwdriver to unscrew the 4 combination screws(6) on both sides of the PCS

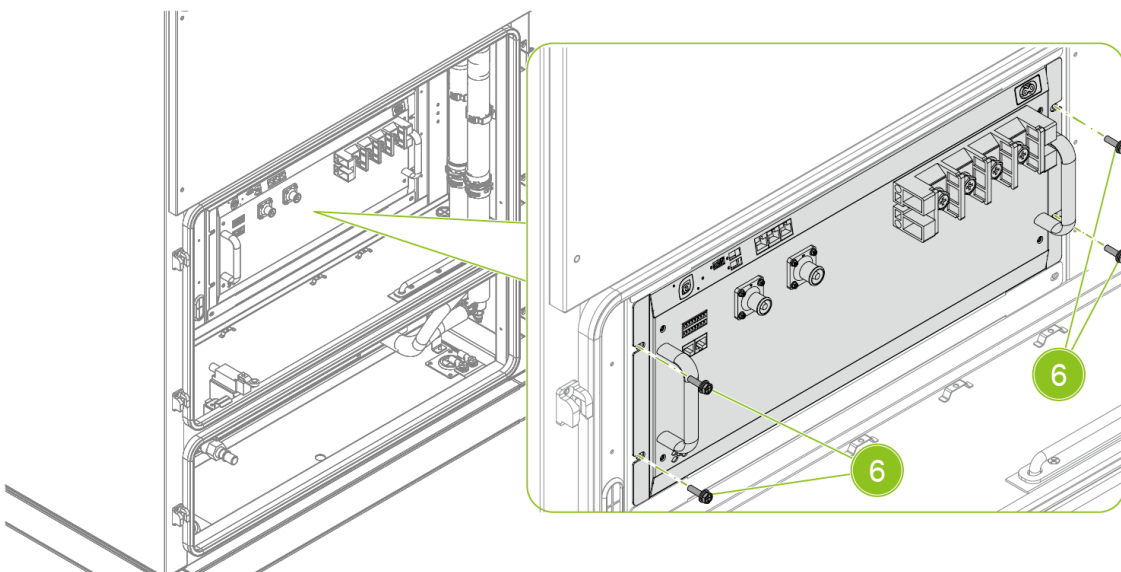

Fig. 9-33 Remove the combination screws

4. Hold the handle of the PCS and slowly pull the PCS out.

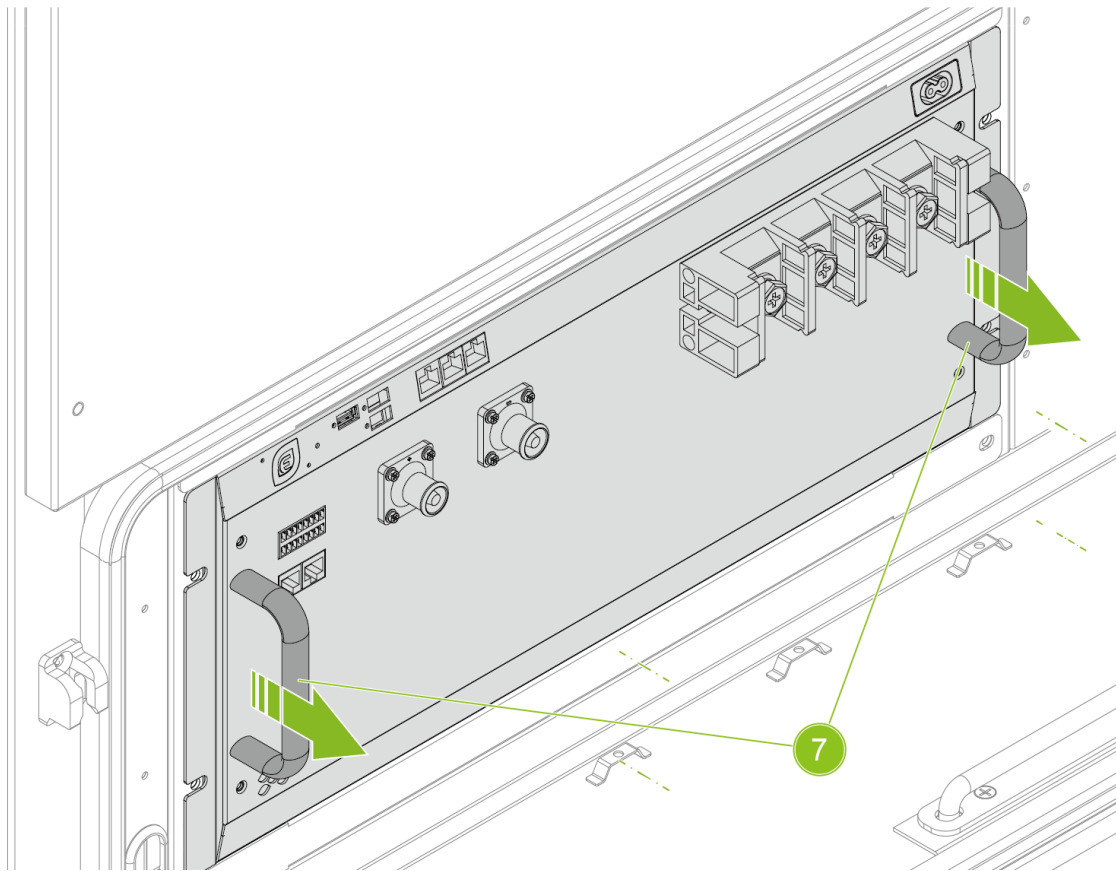

Fig. 9-34 Pull out the PCS

5. Install the new PCS and fixing screws, AC connection cables, and DC connection cables.



NOTICE!

Use a torque gun to fix the combination screws in step 3.

Torque: 6 ± 0.6 N·m.

6. After the PCS is powered on again, connect to the PCS operation interface with the upper computer for program verification or update.

9.5. Dehumidifier Maintenance Procedure

Table 9-7 Dehumidifier maintenance procedure

Frequency	Category	Maintenance standard	Detection method	Handling method
Annual	Reliable operation of the fan.	<p>The fan blades are intact and rotating.</p> <p>The fan operates smoothly without abnormal noise.</p>	Visual inspection	<p>After power off for 10 minutes, check the fan for tightness and check if there are any internal cables or other obstructions interfering with the fan rotation. If the fan is faulty, please replace it.</p>
	Wiring	Check for looseness	Visual inspection	After powering off for 10 minutes, check if the wiring has become loose.

9.6. Power Distribution Box Maintenance

9.6.1. Maintenance Procedure



For detailed maintenance procedures, please refer to the power distribution box user manual.

9.6.2. Replacement

1. Power off the system, refer to section 7.6 Power-off Procedure.
2. Remove the 6 combination screws (1).

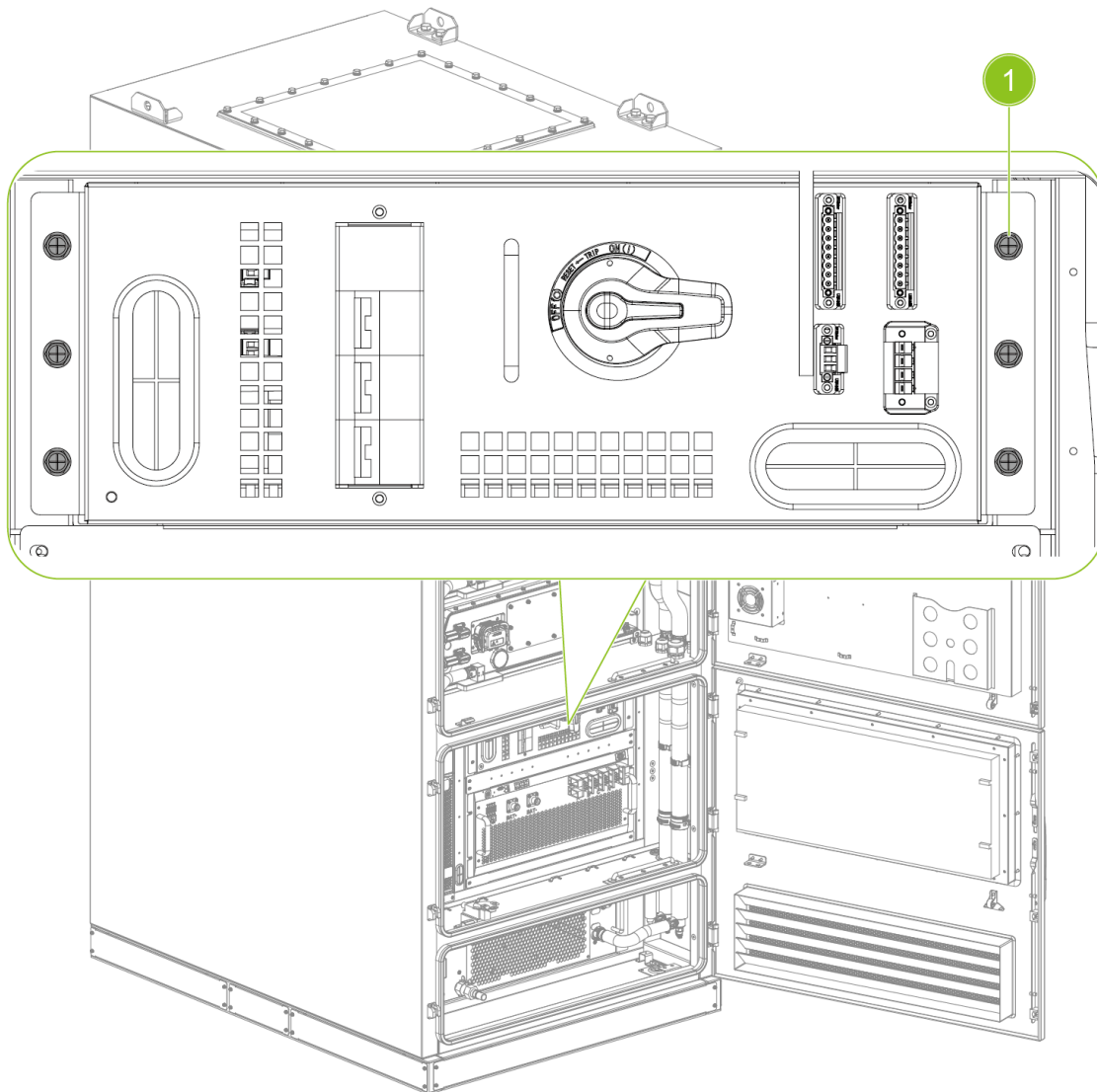

Fig. 9-35 Remove the combination screws

3. Hold the handle (2) and pull out the power distribution box.

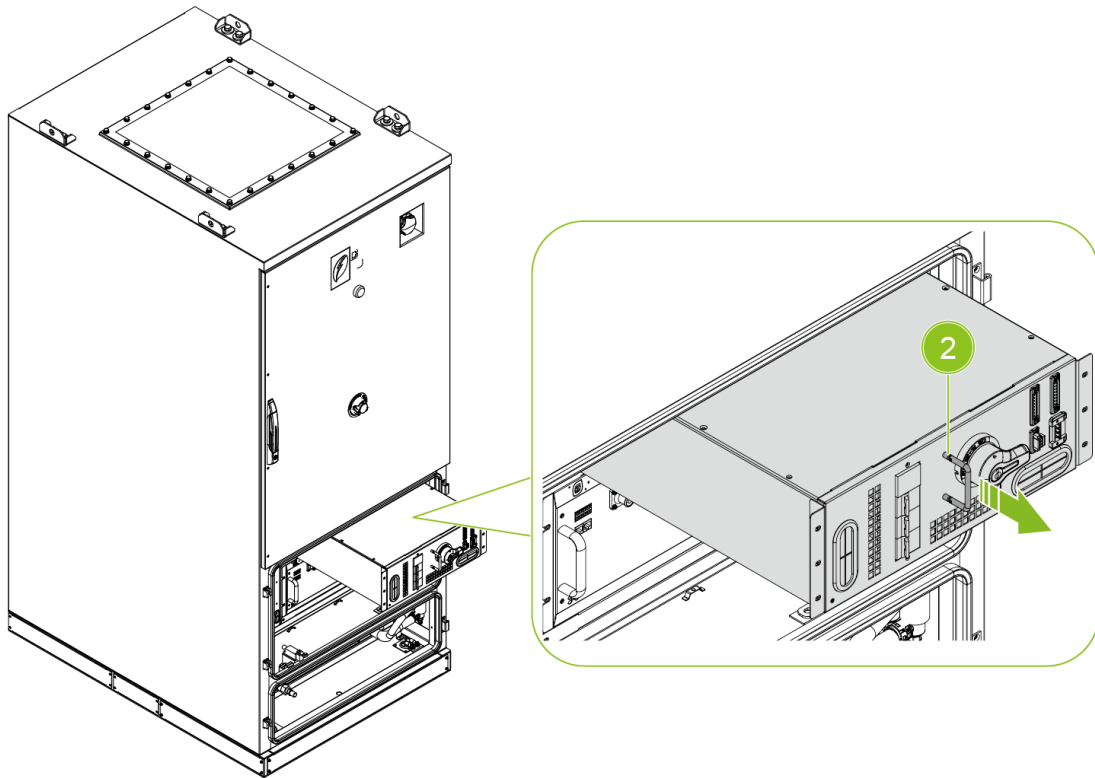

Fig. 9-36 Pull out the power distribution box

4. Install the new power distribution box in the reverse order of removal.

9.7. High Voltage Box Replacement

1. Power off the system, refer to section 7.6 Power-off Procedure.
2. The location of high voltage box is shown in Fig. 2-6 Battery system.
3. Remove all external cables and mark them.
4. Remove the combination screws (1) and fixing plates (2).

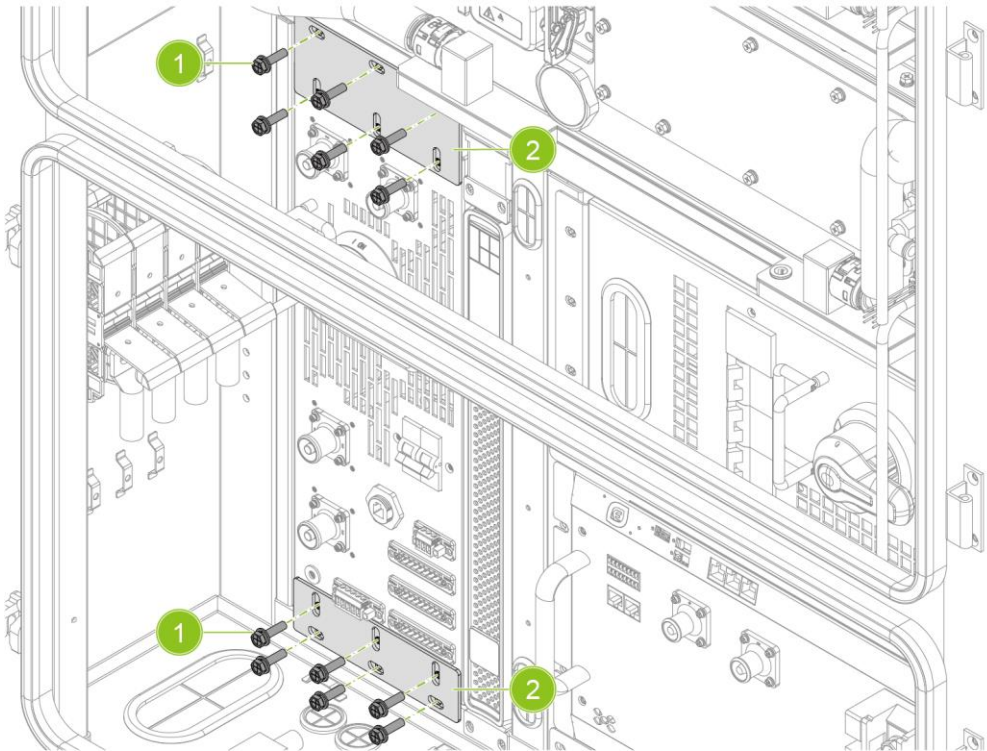

Fig. 9-37 Remove combination screws and fixing plate

5. Hold the handle (3) and pull out the high voltage box.

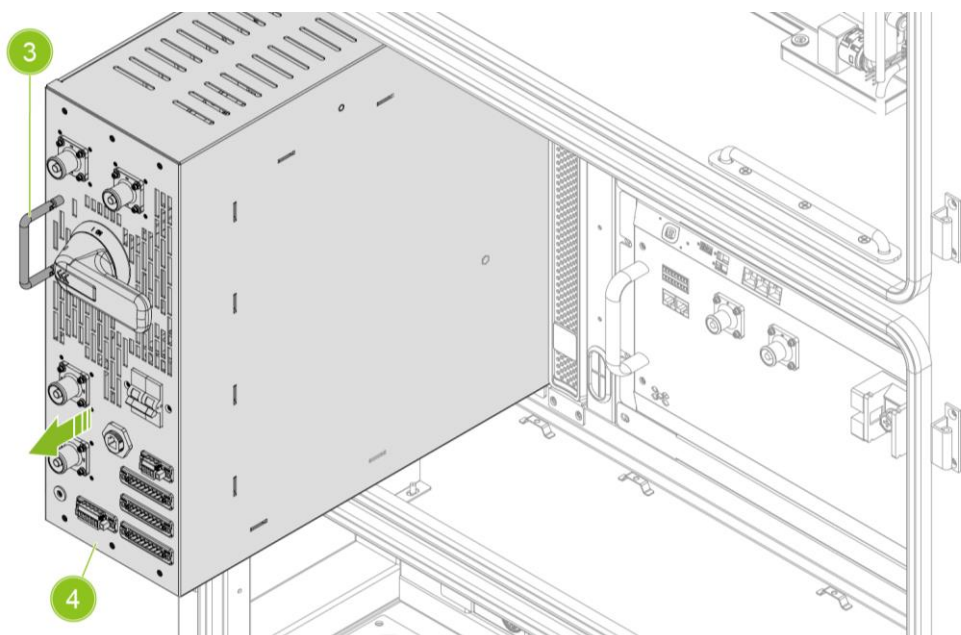

Fig. 9-38 Pull out the high voltage box

6. Install the new high voltage box and tighten the screws.



NOTICE!

Use a torque gun to fix the combination screws in step 3.

Torque: 6 ± 0.6 N·m.

7. Connect the cables according to the electrical diagram and cable labels.

9.8. Cooling Fan Maintenance

9.8.1. Maintenance Procedure

The cooling fan is installed on the backplane of the equipment.

Regular maintenance of your cooling fans is essential to ensure optimal performance, prevent overheating, and extend the lifespan of the equipment.



DANGER!

Before performing any maintenance, you must power-off the equipment.

No.	Maintenance Items	Confirm
1	Visual Inspection	Conduct a quick visual check of the cooling fan. Look for any obvious signs of damage, such as cracked blades, loose mounting screws, or frayed wires. Listen for any unusual noises (like grinding or rattling) when the fan is running, as this often indicates a bearing issue or an obstruction.
2	Cleaning Dust and Debris	<p>Dust buildup is the most common enemy of cooling fan.</p> <ul style="list-style-type: none"> • Surface Cleaning: Use a soft brush or a microfiber cloth to wipe away loose dust from the fan blades and the protective grille. • Deep Cleaning: Use a can of compressed air to blow out dust from hard-to-reach areas. <p><i>Tip:</i> When using compressed air, hold the fan blades in place to prevent them from spinning freely. Spinning the fan too fast with compressed air can generate back-voltage and damage the motor or bearings.</p>
3	Checking Obstructions for	Ensure that there are no cables, debris, or other objects blocking the airflow path or touching the fan blades. Even a small wire touching the blades can cause significant noise and imbalance.

9.8.2. Cooling Fan Replacement

1. Remove the 12 hexagon socket screws (1), take off the compartment backplane (2).

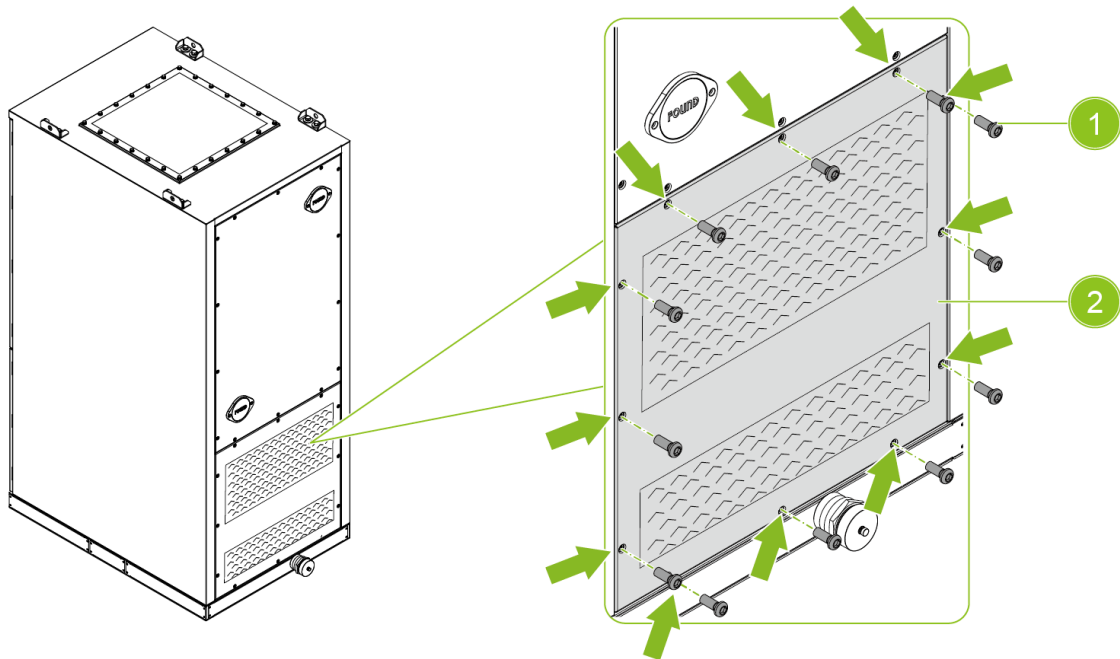

Fig. 9-39 Remove equipment compartment backplane

2. Cut the cable ties of the fan and temperature control switch harness, remove the wiring on the fan.
3. Loosen the 8 M6X16 combination screws (1), remove the fan assembly (2) from the back door.

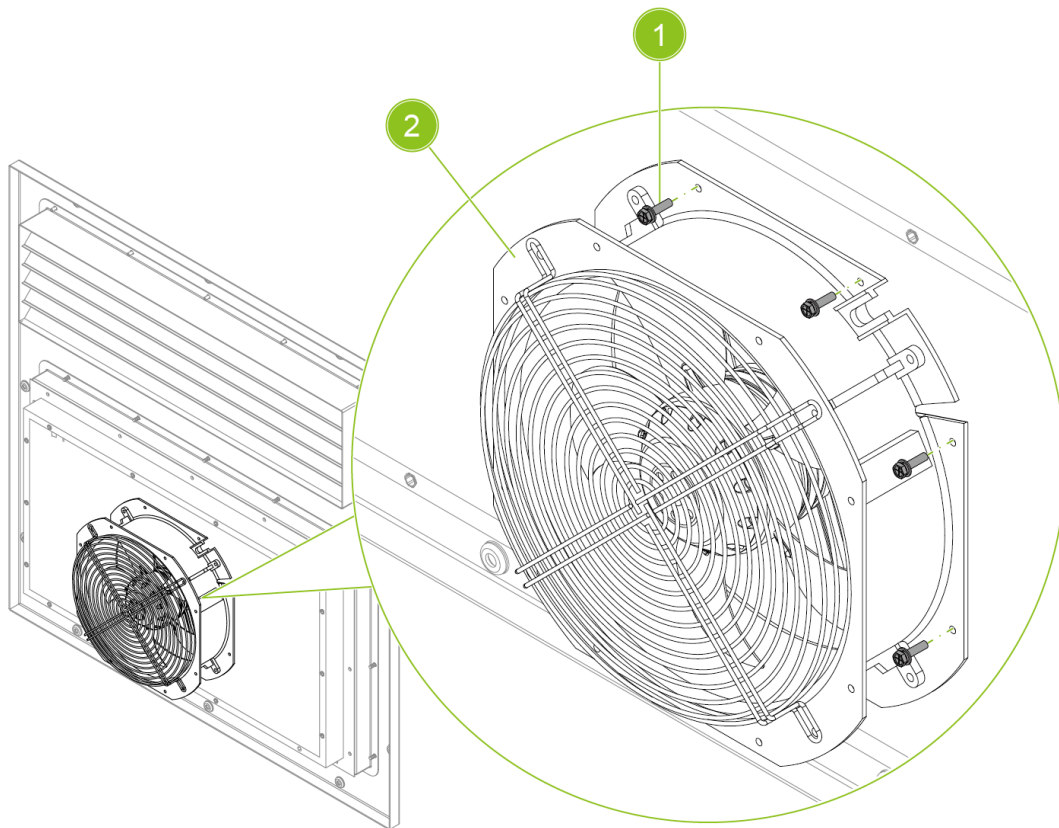

Fig. 9-40 Fixing holes of the cooling fan mounting plate

- Loosen the 4 combination screws, remove the fan grill (3).

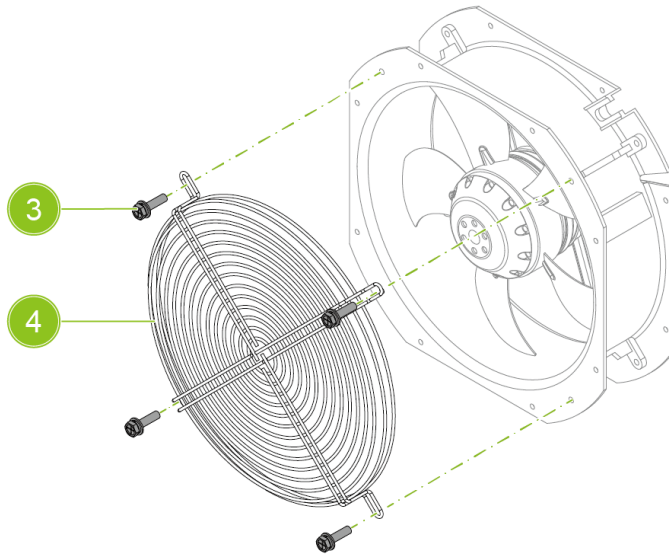

Fig. 9-41 Fixing holes of the cooling fan mounting plate

- Install the fan grill on the new heat dissipation fan, tighten the 4 combination screws.
Torque: 5.9 ± 0.2 N·m.
- Install the fan assembly on the back door, tighten the 8 M6x16 combination screw.
Torque: 5.9 ± 0.2 N·m
- Install the back door on the cabinet, tighten the 12 hexagon socket screws.
Torque: 5.9 ± 0.2 N·m.

9.9. UPS Maintenance

9.9.1. Maintenance Procedure

Equipment maintenance

To ensure the smooth progress of preventive maintenance, please keep the area around the equipment clean and dust-free. If there is a lot of dust in the atmosphere, use a vacuum cleaner to clean the exterior of the equipment.

To fully utilize the battery's lifespan, it is best to maintain the device's ambient temperature at 25°C (77 °F).

The rated lifespan of the battery is 3-5 years. The actual lifespan depends on the frequency of battery usage and the ambient temperature (in environments above 25 °C, the lifespan is halved for every 10°C increase).

If the UPS needs to be moved, please ensure that the UPS is powered off.

Typically, batteries that exceed their expected lifespan will significantly reduce runtime. Replace the battery at least every 4 years to ensure the device operates at peak performance.

Under low-temperature conditions (below 10°C), the remaining battery time will decrease.

Storage equipment

If you need to store the equipment for a long time, please connect the UPS to the grid at least once every 6 months to charge the battery. The internal battery charges to 90% capacity within 3 hours. However, Eaton recommends that the battery should be charged for 48 hours after long-term storage.

Please check the battery charging date on the carton label. If the date has passed and the battery has never been charged, do not use the UPS. Please contact your service representative.

9.9.2. UPS Replacement

1. Power off the equipment, refer to section 7.6 Power-off Procedure.
2. Remove the 12 hexagon socket screws (1), take off the compartment backplane (2).

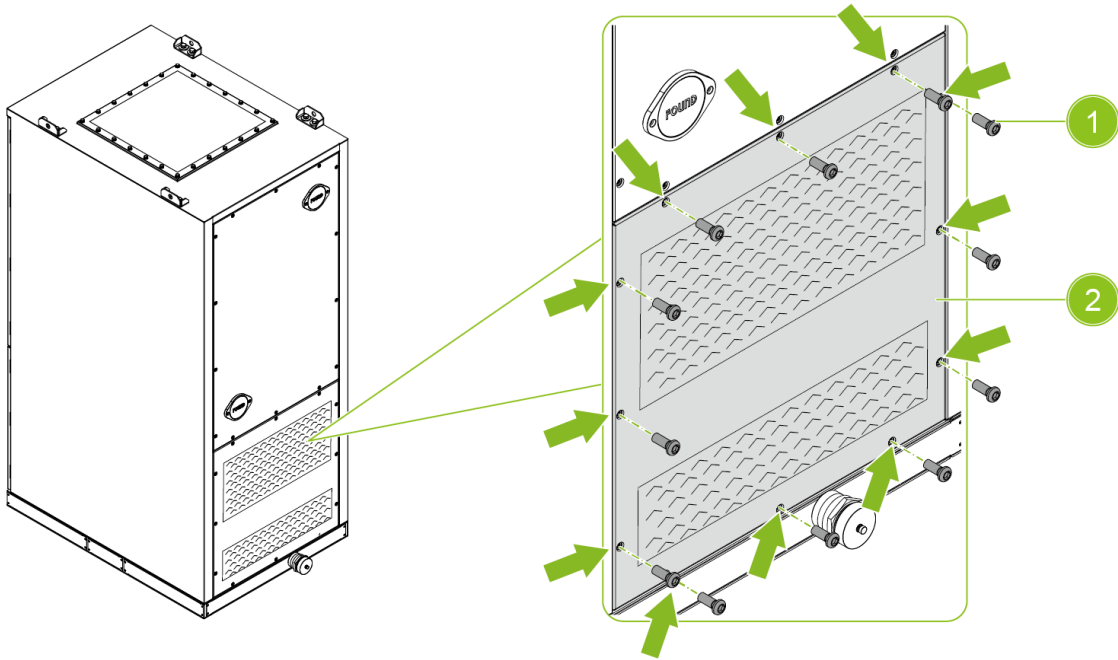

Fig. 9-42 Remove equipment compartment backplane

3. Find the UPS, the UPS location is shown in Fig. 2-16 Power distribution box overview.
4. Record the connection of the UPS rear interfaces, then remove the cable terminals.
5. Unplug the UPS power supply socket (3).



Fig. 9-43 UPS rear view

6. Remove the UPS front mounting bolts (4) and pull out the UPS.

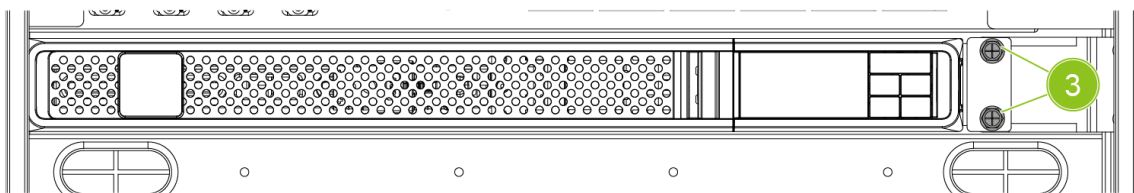

Fig. 9-44 UPS front view

7. Replace the new UPS, insert it into the original position, install the fixing bolts, and connect the incoming and outgoing lines.



NOTICE!

Use a torque gun to fix the combination screws in step 4.

Torque: 6 ± 0.6 N·m.

8. Power on and set the UPS voltage and frequency parameters to match the project requirements.
9. Check for any missing or uninstalled accessories, etc.

9.10. Circuit Breaker Maintenance Procedure

9.10.1. Circuit Breaker Maintenance

The maintenance cycle of the circuit breaker is usually recommended by the manufacturer, generally once a year, but it may also be adjusted according to the operating environment and conditions. The following items should be noted during maintenance:

1. Check appearance: Check whether the circuit breaker has cracks, deformation, or other damage.
2. Cleaning: Remove dust and dirt to prevent overheating or poor contact.
3. Check wiring: Ensure the wiring is secure, without looseness or corrosion.
4. Test operation: Test whether the circuit breaker can operate smoothly and whether the trip and reset functions are normal.
5. Check trip records: Record the number of trips and the reasons, analyze if there are potential issues.
6. Safety measures: Take appropriate safety measures during maintenance, such as turning off the power, using insulated tools.



IMPORTANT!

Regular maintenance can extend the service life of the circuit breaker and ensure it provides necessary protection at critical moments.

9.10.2. Miniature Circuit Breaker Replacement

The steps for replacing a miniature circuit breaker are as follows:

1. First, ensure that the power is turned off, use a screwdriver to loosen the cross screws of the circuit breaker, and then disconnect the wiring tab from the circuit breaker.

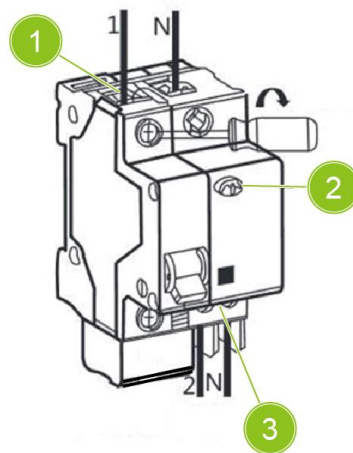

Fig. 9-45 Circuit breaker

1. Incoming terminal

2. Test button (Press once a month)

3. outgoing terminal

- Place the new circuit breaker in the original position, ensuring that the circuit breaker is aligned with the mounting plate or rail. Then, insert the wiring tab into the blade socket of the circuit breaker and secure it with a nut or bolt.

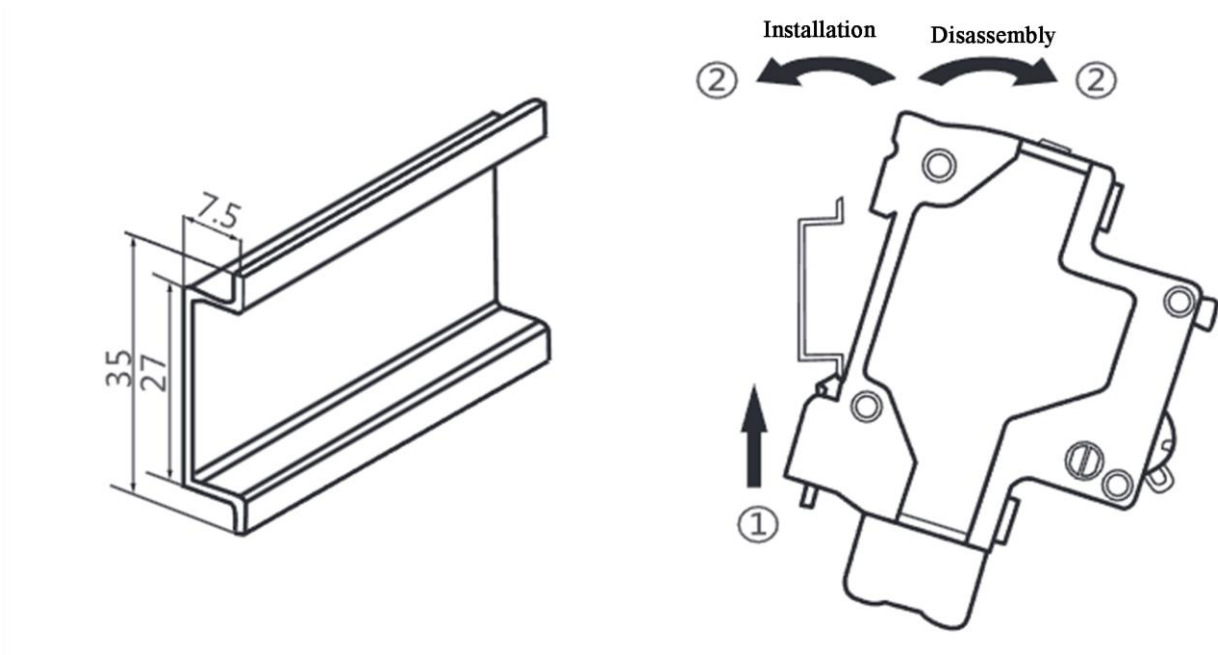

Fig. 9-46 Circuit breaker replacement

- According to the original wiring diagram, connect the wires of the original circuit to the new circuit breaker in sequence, ensuring that the connections are secure and reliable. Use an electric screwdriver or torque wrench to tighten the wiring bolts or nuts one by one.
- After completing the circuit breaker replacement, restore the power supply and perform functional testing of the circuit breaker. By operating the switch, verify whether the closing and opening functions of the circuit breaker are normal.

9.10.3. Molded Case Circuit Breaker Replacement

1. Power off the equipment, refer to section 7.6 Power-off Procedure.
2. Take out the power distribution box, refer to section 9.6.2 Replacement.
3. Remove the fixing screws on the cover plate of the distribution box and take off the cover plate.

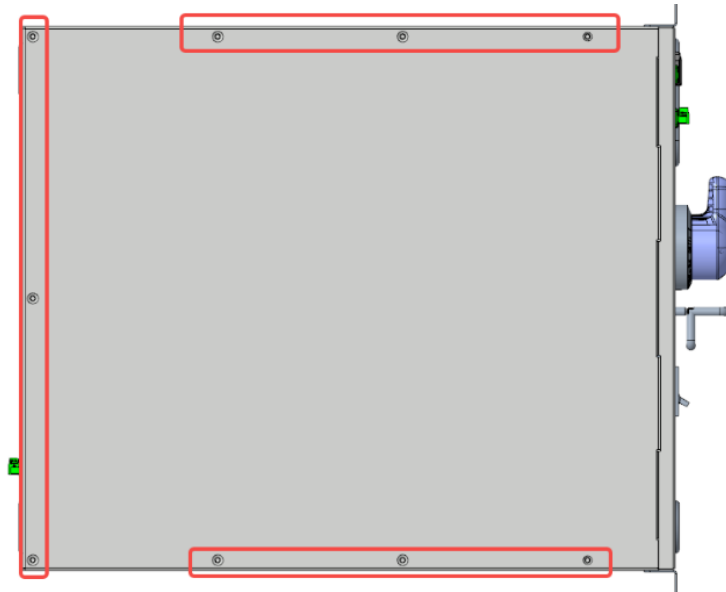

Fig. 9-47 Remove the fixing screws on the cover plate of the distribution box

4. Remove the copper busbar and connecting cable connected to the circuit breaker, and mark them.

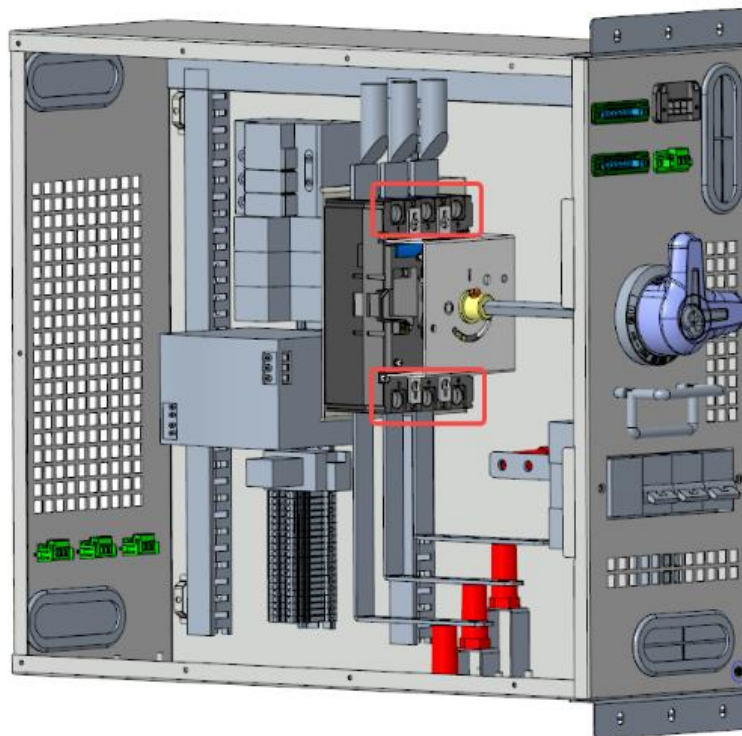

Fig. 9-48 Remove the copper busbar and cable connected to the circuit breaker

5. Remove the fixing bolts of the circuit breaker and remove the circuit breaker.

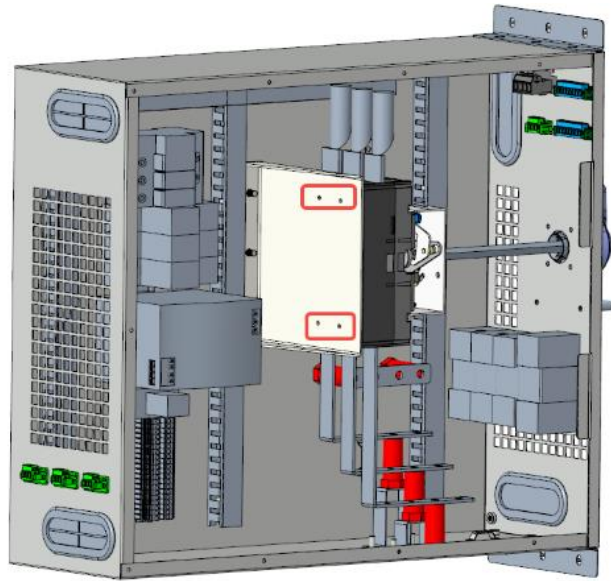

Fig. 9-49 Remove the fixing bolts of the circuit breaker and remove the circuit breaker

6. Replace the new circuit breaker and restore the connecting copper busbar and cable.
7. The distribution box is installed in place and wired.
8. Replace the switching power supply, miniature circuit breaker, energy meter, etc., following the same steps as above.

9.11. Cabinet Maintenance

The product appearance should be kept intact. If there is paint peeling, it should be repainted immediately. Visually inspect the extent of paint damage on the product, prepare the corresponding tools and materials, and assess the quantity of materials on-site based on the repainting situation.

Check the appearance damage and select the appropriate solution based on different levels of damage.

- Solution 1: Surface dirt can be wiped off
- Solution 2: Surface dirt cannot be wiped off
- Solution 3: Primer damage exposes the substrate

Operation steps of Solution 1

1. Prepare tools and materials: cloth, water, alcohol or other non-corrosive cleaners.
2. Use a cloth (or other scrubbing tool) dipped in water to scrub the dirty areas of the surface. use a cloth (or other scrubbing tool) dipped in water to scrub the dirty areas of the surface.

Operation steps of Solution 2

1. Prepare tools and materials: sandpaper, cloth, water, alcohol, zinc-rich primer, brush, and paint with the corresponding color number of the cabinet.
2. Use sandpaper to sand the areas where the surface paint is raised or scratched to make the surface smooth.
3. Use a cloth dipped in water or 97% alcohol to scrub the damaged areas to remove surface stains.
4. After the surface is dry, use a soft brush to touch up the paint on the scratched areas, and try to keep the paint application as even and consistent as possible.

Operation steps of Solution 3

1. Prepare tools and materials: sandpaper, cloth, water, alcohol, brush, and cabinet paint with the corresponding color code.
2. Gently sand the damaged area with fine sandpaper to remove dirt or rust.
3. Moisten a cloth with anhydrous ethanol and wipe the sanded or repair area to remove surface dirt and dust, then dry it with a clean cloth.
4. Use a brush or spray gun to apply zinc-rich primer to the damaged coating area.
5. Depending on the degree of paint damage, choose one method from spray paint, brush paint, or spray gun application to evenly touch up the damaged coating area until the damage marks are no longer visible.
6. After painting, let it sit for about 30 minutes, then observe whether the touched-up area meets the requirements.

10. Quality Assurance

10.1. Liability Exemption



NOTICE!

The Company shall not be liable for any consequences or losses arising from the following circumstances and reserves the right to refuse warranty services:

1. Exceed the quality assurance period of the product.
2. Cannot provide product serial number or the SN is not clear/complete. Incorrect or inappropriate use of the product (including installation and use).
3. Damage during transportation/storage/handling.
4. Misuse, abuse, intentional damage, negligence or accidental damage.
5. Improper commissioning, testing, operation, maintenance or installation performed by customer, including but not limited to:
 - Failure to meet safe operating environment or system requirements of external electrical parameters provided in written document.
 - Failure to operate the covered product in accordance with the product's operating manual or user guide.
 - Relocate and reinstall systems not in accordance with the requirements of Chint power.
 - Unsafe electrical or chemical environment or other similar kind of conditions.
 - Direct failure caused by wrong voltage or faulty power system.
 - Unauthorized disassembly of the products, or unauthorized modification of the product or provided software.
6. Entrust installation, maintenance personnel not designated by the CHINT to install, repair and disassemble the products.
7. Damages caused by ignoring the safety warnings in the manual or break the rules in relevant statutory safety regulations.
8. Damages caused by operating environment beyond the requirements of the product user manual or failure to commissioning, install, use and maintain the equipment according to the requirements of the product user manual.
9. Unforeseen disasters or irresistible accidents (including but not limited to acts of public enemies, acts of government agencies or domestic or foreign institutions, vandalism, riots, fires, floods, typhoons, explosions or other disasters, epidemic or quarantine restrictions, labor disturbances or labor shortages, accidents, cargo embargoes or any other events beyond the control of CHINT).
10. The lightning protection measures have not been implemented or are not in accordance with standards (Photovoltaic systems' lightning protection measures should comply with the relevant national and IEC standards. Otherwise, it may result in damage to photovoltaic devices such as modules, inverters, distribution facilities, etc., due to lightning strikes).

11. Equipment failure or software damage caused by using non-standard components/accessories, connection of incompatible configurations (such as batteries, etc.) or other brand products or accessories without permission, improper configuration selection/storage/use.
12. Abnormal battery degradation or damage caused by improper use or maintenance.
13. Other circumstances that are not covered by the company's after-sales warranty agreement.

10.2. Quality Clause (Warranty Clause)

1. For products that fail during the warranty period, our company will repair or replace new products free of charge.
2. Customer shall present the invoice of the product and date of purchase. At the same time, the trademark on the product should be clearly visible, otherwise we have rights to refuse quality assurance.
3. The unqualified product under replacement should be returned to our company.
4. It is necessary to provide a reasonable time for the company to overhaul the equipment.
5. For more warranty terms, refer to the applicable standard warranty policy in place at time of purchase.

If you have any questions about the equipment, please contact us, we will be very happy to help you.

11. Disposal







**WARNING!**

This device cannot be disposed of and scrapped as household waste.







When the service life of the equipment or its internal components expires, please dispose of or recycle it in accordance with the applicable electrical waste disposal or recycling laws in the installation location.







Annex

Annex 1 Personal Protective Equipment List

No.	Category	Sample	Requirements
1	Safety Helmet		Before entering the construction site, the helmet should be used correctly to protect the head. The helmet should meet the requirements of ANSI Z89.1 "Industrial Safety Helmets"
2	Electrician's Clothing		Field service personnel need to wear electrician uniforms
3	Protective shoes		During the transportation and installation of battery PACK, protective shoes must be worn. Field service personnel need to wear protective shoes
4	Insulating gloves		On-site maintenance personnel need to wear insulated gloves
5	Mask		On-site service personnel need to wear masks
6	Protective glass		Shield the eyes from hazards like flying debris, chemical splashes, or intense light.

Annex 2 List of Tools

No.	Name	Material	Specification	Sample	Qty.	Remarks	Calibration date	Validity Period
1	Laptop				2	Important Tool		
2	Tape Measure	Steel	5 m		1	Important Tool		
3	Wrench (insulated)	Stainless steel	1 complete set		1	Important Tool		
4	Socket wrench (insulated)	Stainless steel	1 complete set		1	Important Tool		
5	Insulated torque wrench	Stainless steel	1 complete set		2	Important Tool		
6	Screwdriver	Stainless steel	1 complete set		1	Important Tool		

No.	Name	Material	Specification	Sample	Qty.	Remarks	Calibration date	Validity Period
7	Gradient meter (level)	Aluminum alloy	1000mm		1	Important Tool		
8	Electric wrench				1	Important Tool		
9	Electric drill				1	Important Tool		
10	Multimeter				1	Important Tool		
11	Battery tester		HIOKI 3564		1	Important Tool		
12	Forklift				1	Important Tool		

Annex 3 Suggestions on Anti-corrosion Grades

Grade	Degree of corrosion	Typical environment
C3-M	Medium	Coastal cities' buildings, low-salinity coastal areas, and production sites with condensate water
C4-M	High	Coastal industrial zone, port facilities, chemical plants, bridges, high-salinity coastal areas
C5-M	extreme high	Offshore drilling platforms, cross-sea bridges, ships, areas that are frequently exposed to seawater splashing or immersion

Annex 4 Terms and Definitions

Terms	Definitions
Battery PACK	Battery assembly consisting of battery cells connected in series, parallel, or both, with a pair of positive and negative output terminals, which should also include housings, management and protection components.
High voltage box	It is used for the protection and control during charging and discharging of battery cluster, and consists of the cluster-level battery management unit, relay, fuse, power resistor and disconnecter.
Battery cluster	Battery assembly that is connected by the battery PACK in series and can run independently after being connected with a PCS and ancillary facilities, which shall also include the battery management system, monitoring and protection circuit, electrical and communication interfaces and other components.
PCS	Power Conversion System, accepts the EMS or BMS requirements, and charges and discharges batteries.
BMS	Battery Management System, used to detect the voltage, current, temperature and other parameter information of the battery and manage and control the state of the battery.
ESBMM	Energy Storage Battery Management Module, the slave module in BMS, which is used to collect the voltage and temperature of single battery in the battery PACK, control fans, and achieve the balance management of battery.
ESBCM	Energy Storage Battery Control Module, the main control module in BMS, which enables the real-time monitoring of battery cluster parameters, fault handling, SOC/SOH estimation, insulation detection, alarm display, remote monitoring, relay control, equalization algorithm, and collection of total voltage and main loop current, communication with ESBMM in the system BMS, and communication with the master control module and uploading of real-time battery data.
ESMU	Energy Storage Management Unit, the master control module in BMS, which communicates with the main control module to query the information inside the module, and summarizes the information of multiple battery clusters; communicates with HMI to query on the corresponding HMI; communicates with the background to query in the corresponding background; communicates with PCS to control the charging and discharging of PCS; and inputs and outputs dry contacts as required, and communicates with air conditioning, fire protection and other system equipment as required.
EMS	Energy Management System of the whole power station, used for dispatching, monitoring and management of the whole power station.
LEMS	Local Energy Management System, also local controller, used for managing the local equipment.
Distribution box	It is mainly used to supply power to the system communication components and system equipment, and is arranged in the equipment compartment.

Terms	Definitions
Fire protection system	Mainly including aerosol, detector, audible and visual alarm, etc., which are arranged in the battery compartment.
Thermal management system	Use a liquid cooling unit to adjust the battery temperature within an appropriate range, and uniformly control the temperature of each battery through liquid cooling pipelines and liquid cooling plates.
Circulation	When the battery PACK is charged and discharged once as per the specified standard, it is considered as a cycle.
MSD	Maintenance Switch Disconnecter, used as a manual maintenance switch.
Measurement unit	Unit of voltage: "V" (volt) Unit of current: "A" (ampere) Unit of power: "W" (watt) Unit of capacity: "Ah" (Ampere-Hour) Unit of energy: "Wh" (Watt-Hour) Unit of internal resistance: "mΩ" (milliOhm) Unit of temperature: "°C" (degree Celsius) Unit of length: "mm" (millimeter) Unit of time: "s" (second) Unit of frequency: "Hz" (Hertz) Unit of mass: "kg" (kilogram) Unit of force: "N" (Newton)

SHANGHAI CHINT POWER SYSTEMS CO., LTD

Headquarters: No.5999, Guangfulin Road, Songjiang District, Shanghai, 201616, China

Switchboard: +86-21-37791222-866000

Fax: +86-21-37791222-866001

Website: www.chintpower.com

Service Hotline: +86-21-37791222-866300

Email: service.cps@chint.com

The above information is subject to change without prior notice.

Any unauthorized copying and plagiarism are prohibited.